



US00D340905S

# United States Patent [19]

[11] Patent Number: **Des. 340,905**

Orth, Sr. et al.

[45] Date of Patent: **\*\* Nov. 2, 1993**

[54] **STEP FOR VEHICLE**

[75] Inventors: **Robert J. Orth, Sr.**, Richardson;  
**Kevin W. Wallace**, Wylie, both of  
Tex.

[73] Assignee: **Go Industries, Inc.**, Richardson, Tex.

[\*\*] Term: **14 Years**

[21] Appl. No.: **2,185**

[22] Filed: **Dec. 4, 1992**

[52] U.S. Cl. .... **D12/203**

[58] Field of Search ..... **D12/203; 280/163;**  
**182/90; D25/62, 69**

[56] **References Cited**

**U.S. PATENT DOCUMENTS**

D. 292,904	11/1987	Bielby .....	D12/203
D. 297,135	8/1988	Davenport .....	D12/203
D. 297,230	8/1988	Huff .....	D12/203
2,537,707	1/1951	Russ et al. ....	280/163

*Primary Examiner*—James M. Gandy

*Attorney, Agent, or Firm*—Glaser, Griggs & Schwartz

[57] **CLAIM**

The ornamental design for a step for vehicle, as shown and described.

**DESCRIPTION**

FIG. 1 is a perspective view of a step for vehicle showing our new design;  
 FIG. 2 is a front elevational view of the step for vehicle of our new design;  
 FIG. 3 is a top plan view thereof;  
 FIG. 4 is bottom plan view thereof;  
 FIG. 5 is rear elevational view thereof;  
 FIG. 6 is a side elevational view taken along the lines 6—6 of FIG. 2;  
 FIG. 7 is a side elevational view taken along the lines 7—7 of FIG. 2; and,  
 FIG. 8 is a perspective view of the step for vehicle showing our new design, it being understood that the broken lines are for illustrative purposes only, to illustrate the environment in which the step for vehicle will be used, with such forming no part of the claimed design.

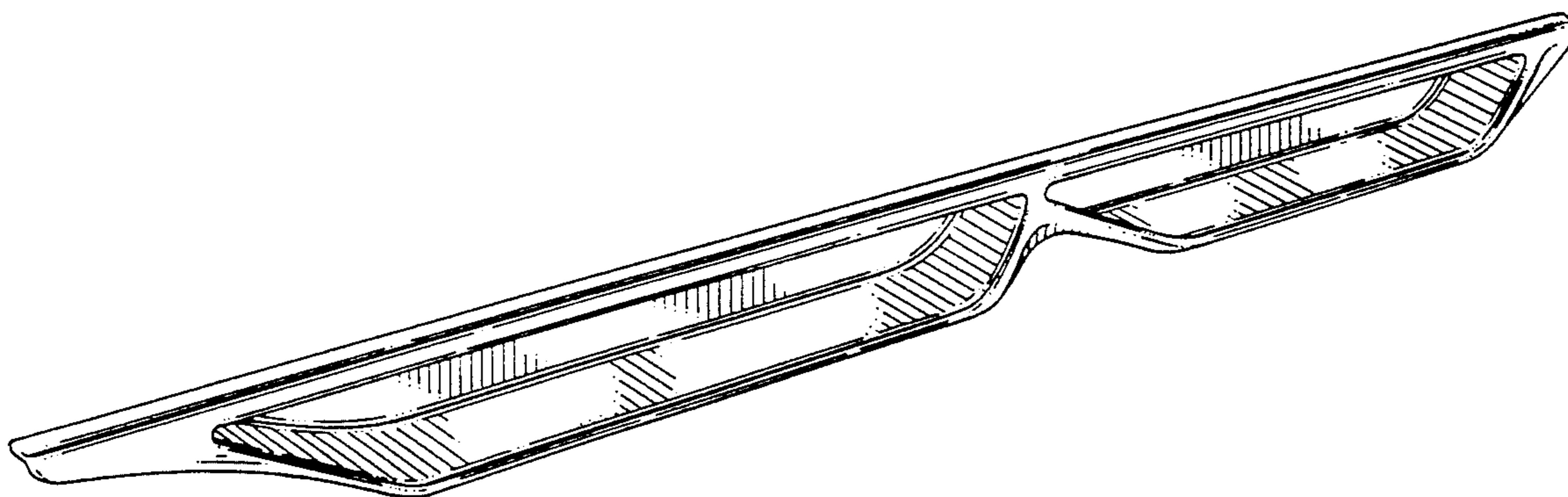

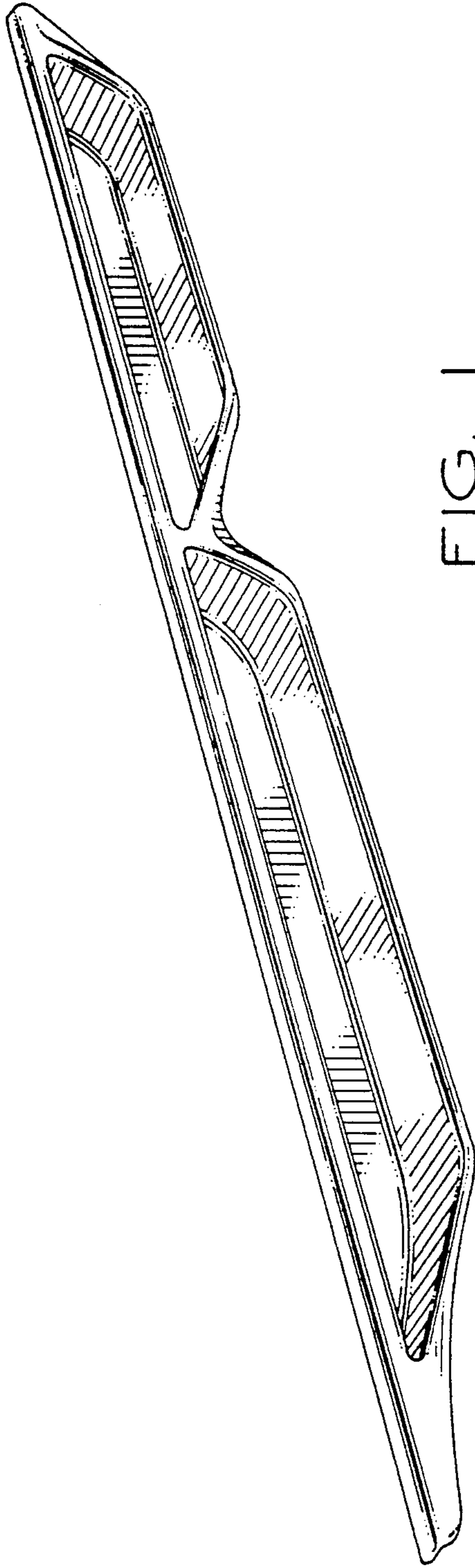

FIG. 1

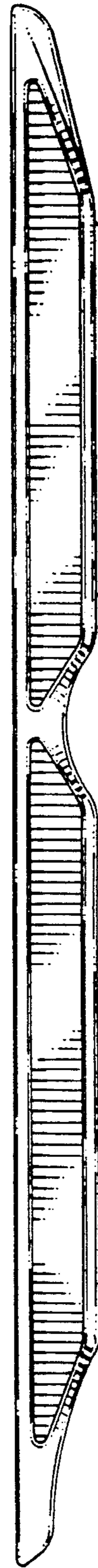

FIG. 2

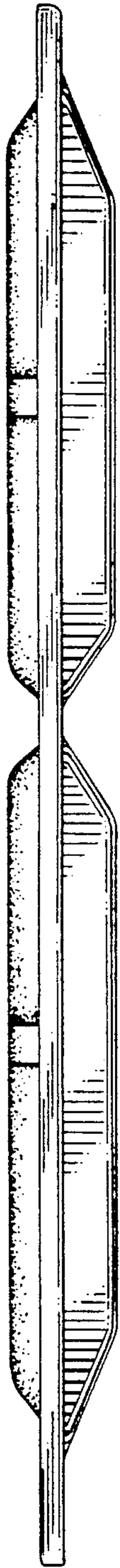

FIG. 3

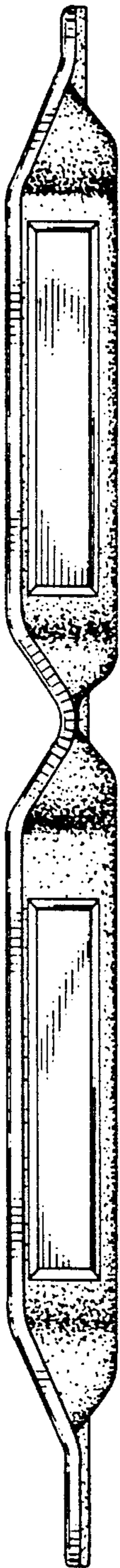

FIG. 4



FIG. 5

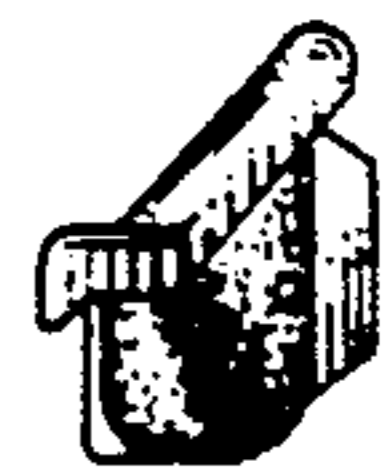

FIG. 6



FIG. 7

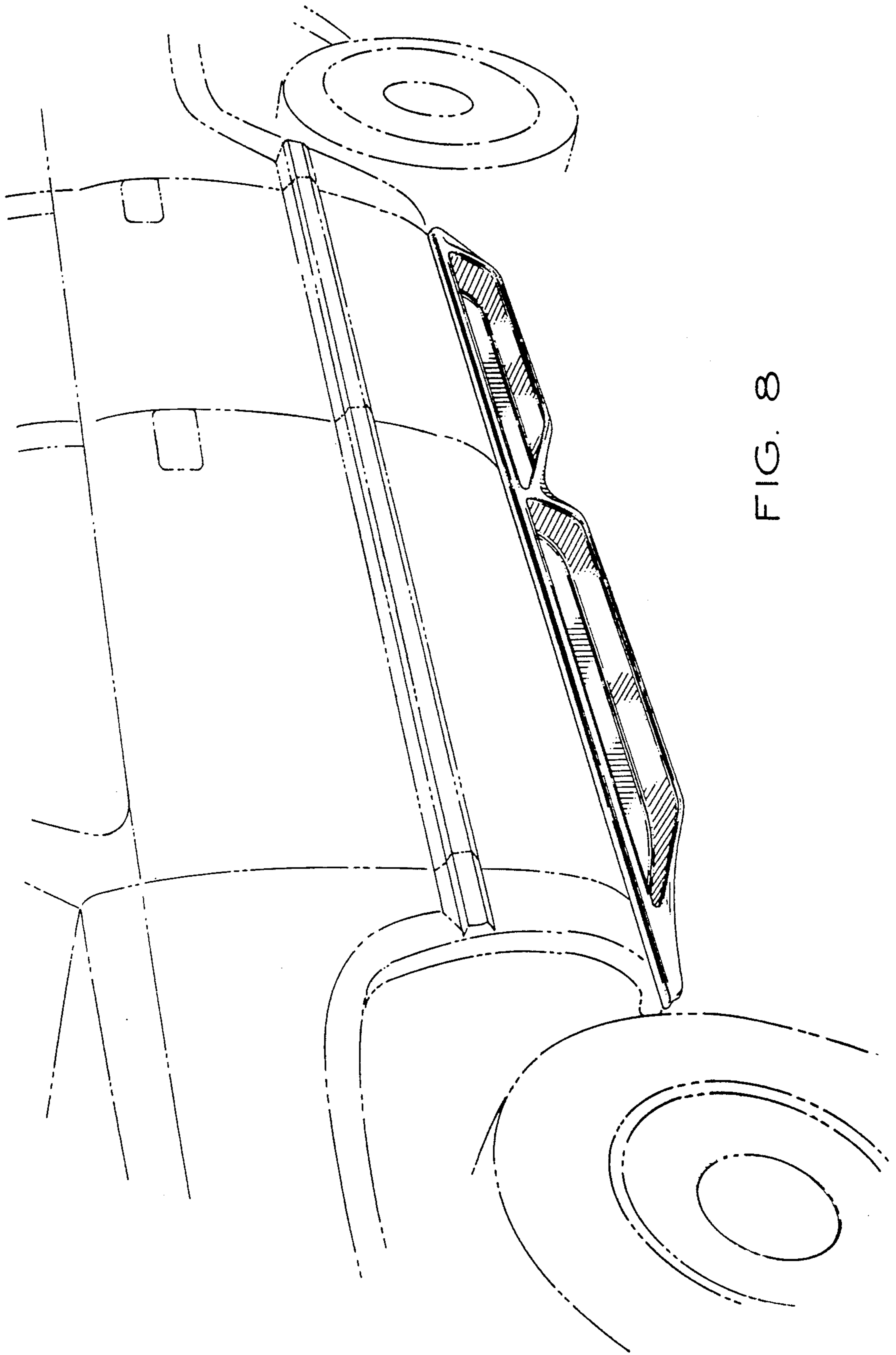

FIG. 8