



US00D340890S

# United States Patent [19]

Martin et al.

[11] Patent Number: **Des. 340,890**

[45] Date of Patent: **\*\* Nov. 2, 1993**

## [54] RAILWAY TRUCK WEAR LINER

[75] Inventors: **Gordon J. Martin**, Rollingstone;  
**Richard M. Ebert**, Winona, both of  
Minn.

[73] Assignees: **Carol Ann Mackay; Helen Lou Kurtz**,  
both of Winona, Minn.

[\*\*] Term: **14 Years**

[21] Appl. No.: **634,343**

[22] Filed: **Dec. 26, 1990**

[52] U.S. Cl. .... **D12/46**

[58] Field of Search ..... **D12/46; 105/339, 199.3,**  
**105/225**

## [56] References Cited

### U.S. PATENT DOCUMENTS

4,237,793	12/1980	Holden et al. ....	105/225
4,380,199	4/1983	Thomson et al. ....	105/225
4,440,095	4/1984	Mathieu ....	105/225
4,825,777	5/1989	Cummins ....	105/225

*Primary Examiner*—Wallace R. Burke  
*Assistant Examiner*—Melody Brown  
*Attorney, Agent, or Firm*—Richard J. Renk

## [57] CLAIM

The ornamental design for a railway truck wear liner, as shown.

## DESCRIPTION

FIG. 1 is a top perspective view of a railway truck wear liner showing our new design;  
FIG. 2 is a bottom side and end perspective view thereof;  
FIG. 3 is an opposite end elevational view thereof; and,  
FIG. 4 is a side elevational view thereof.

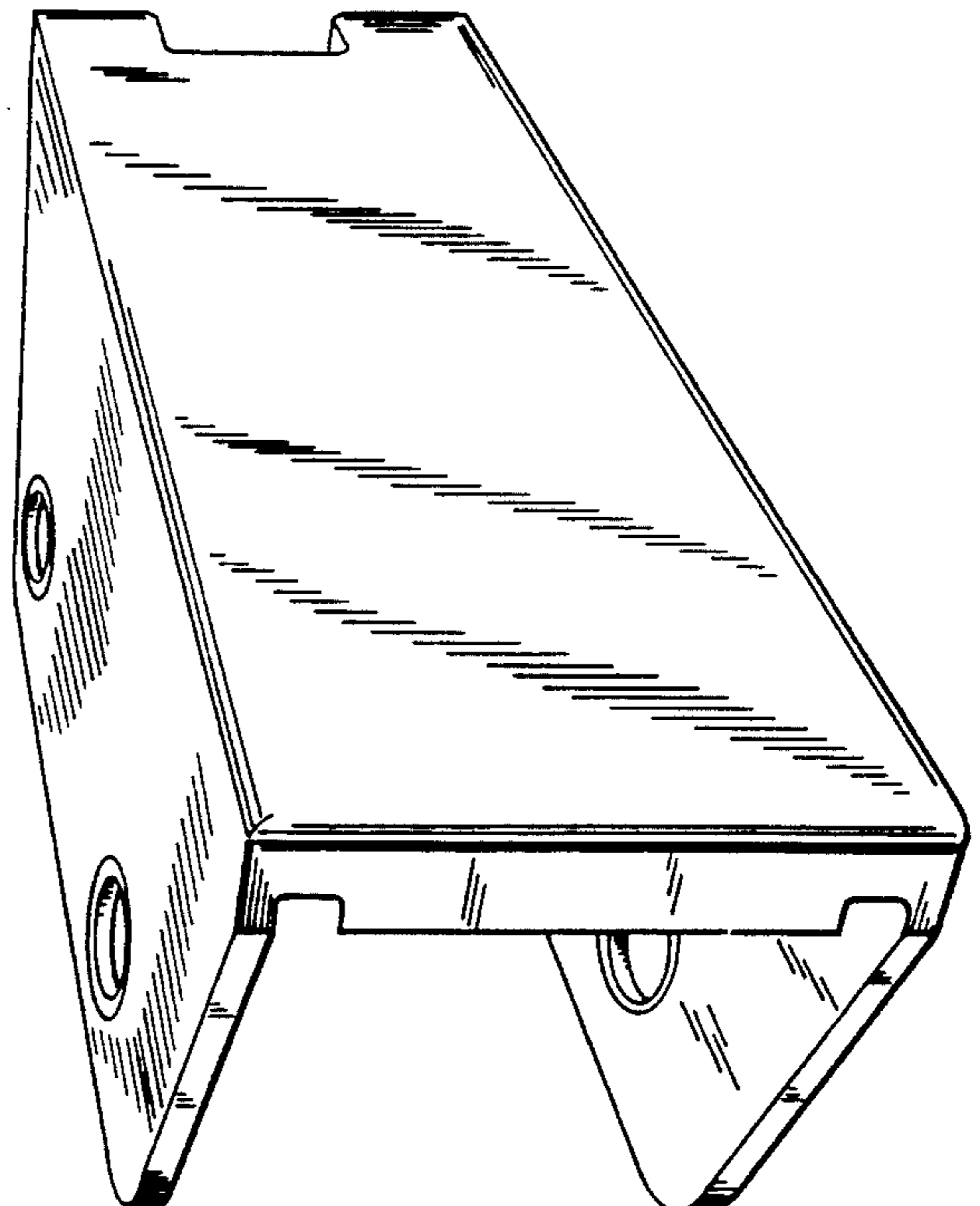
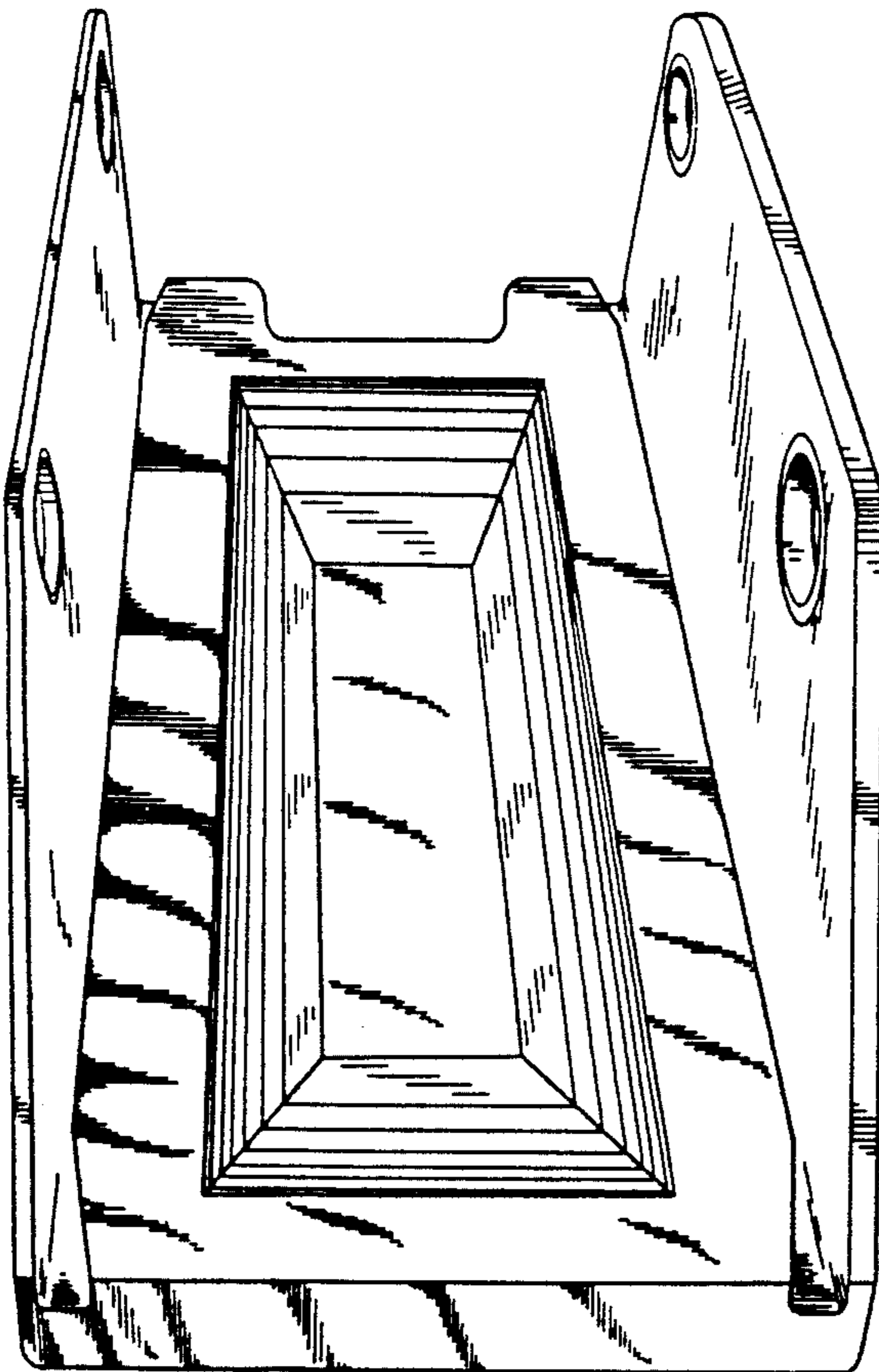

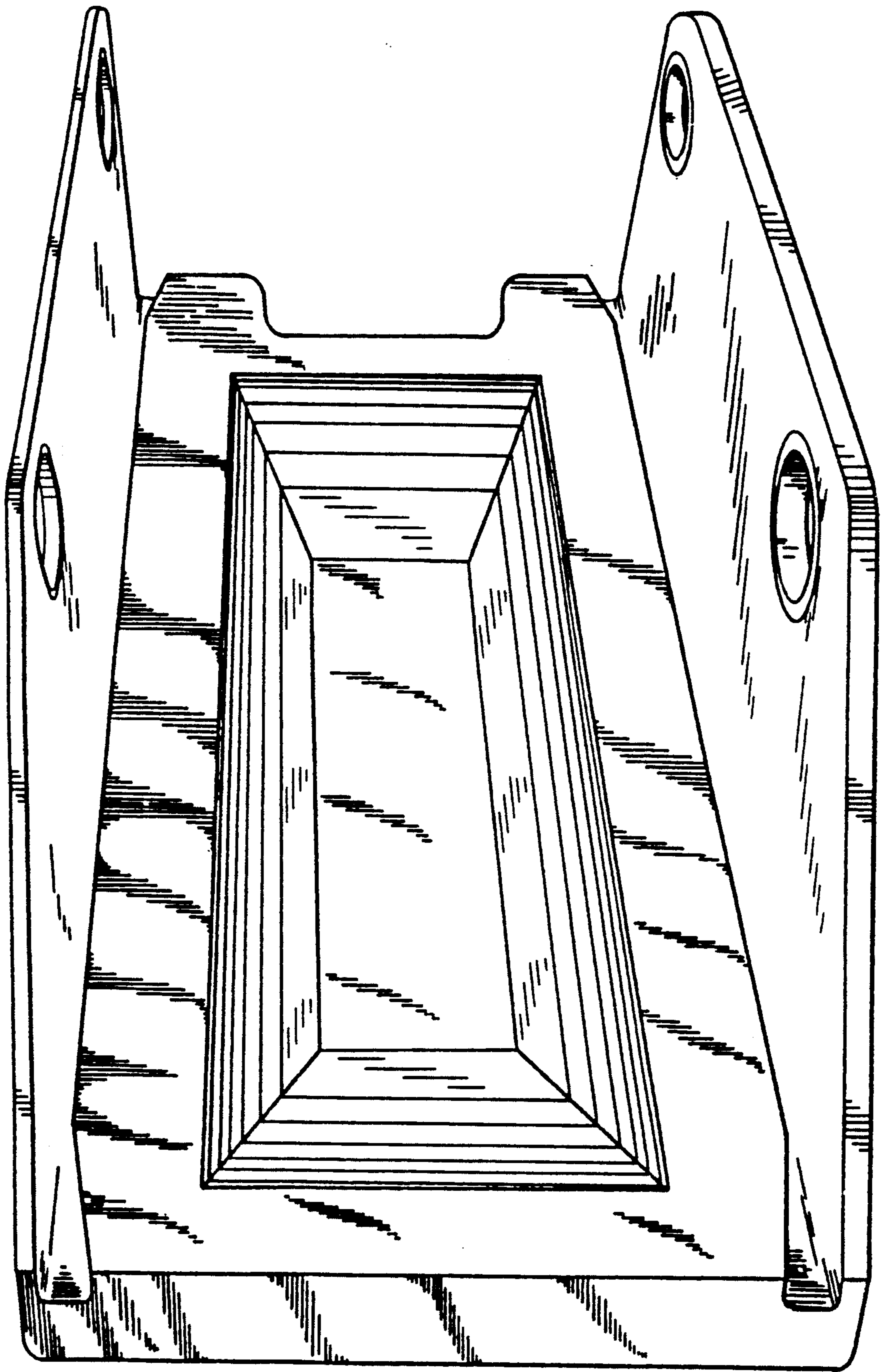

FIG. 1

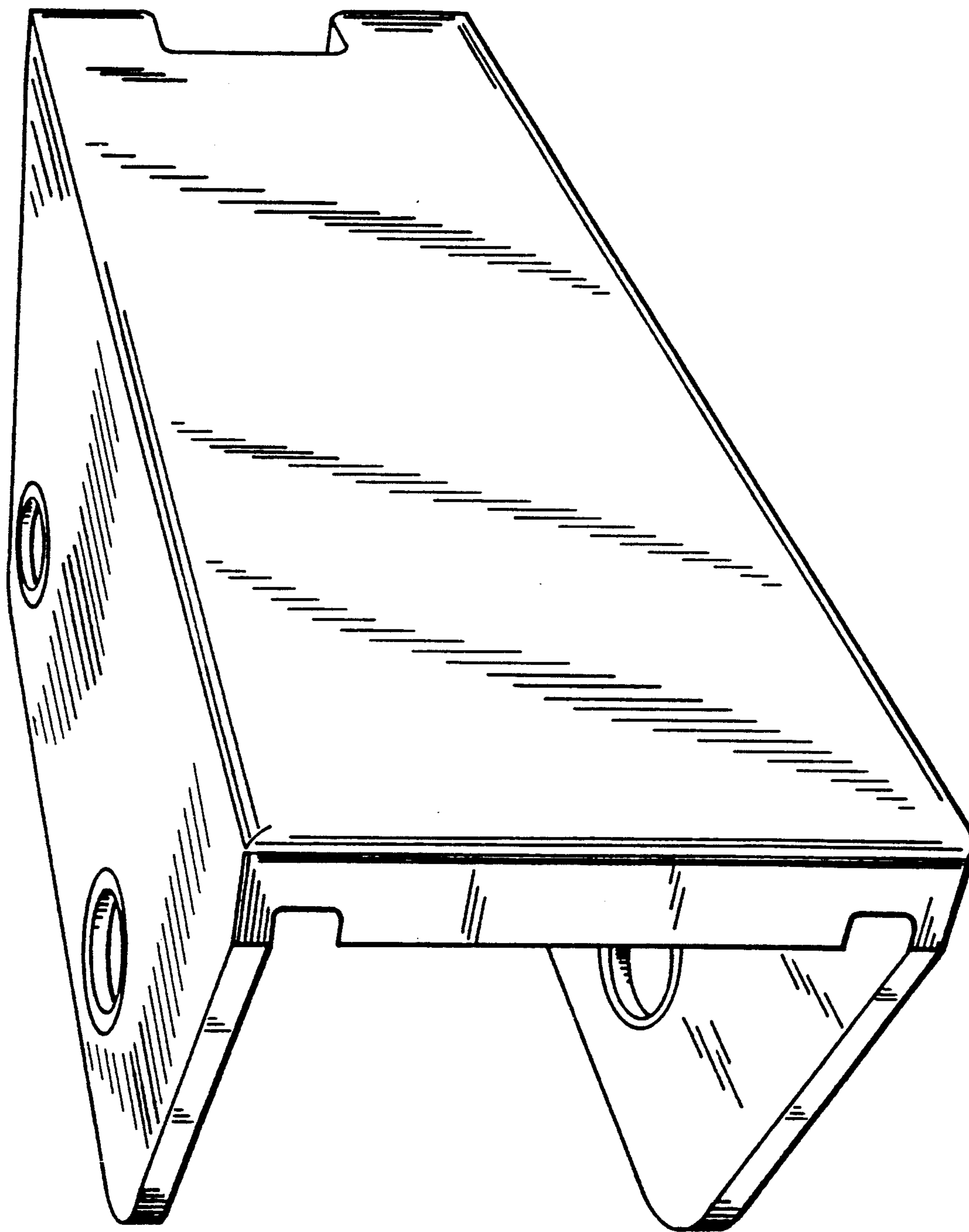

FIG. 2

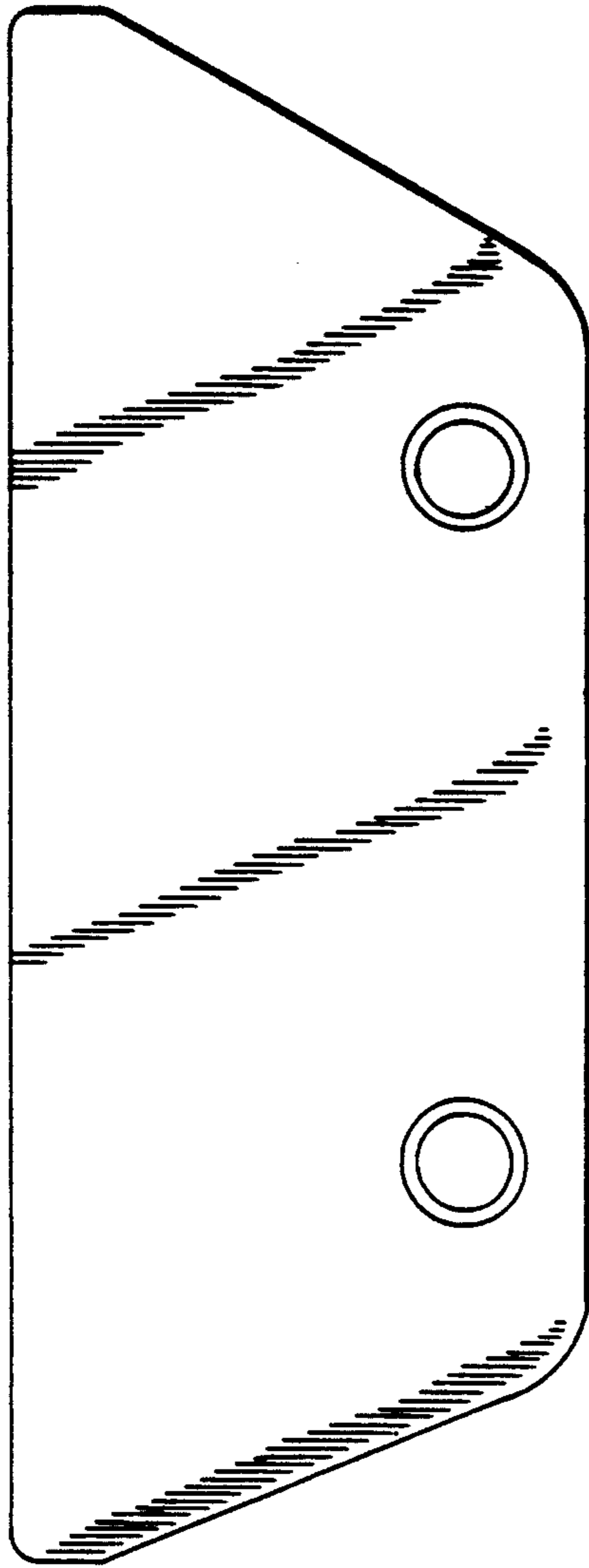

FIG. 4

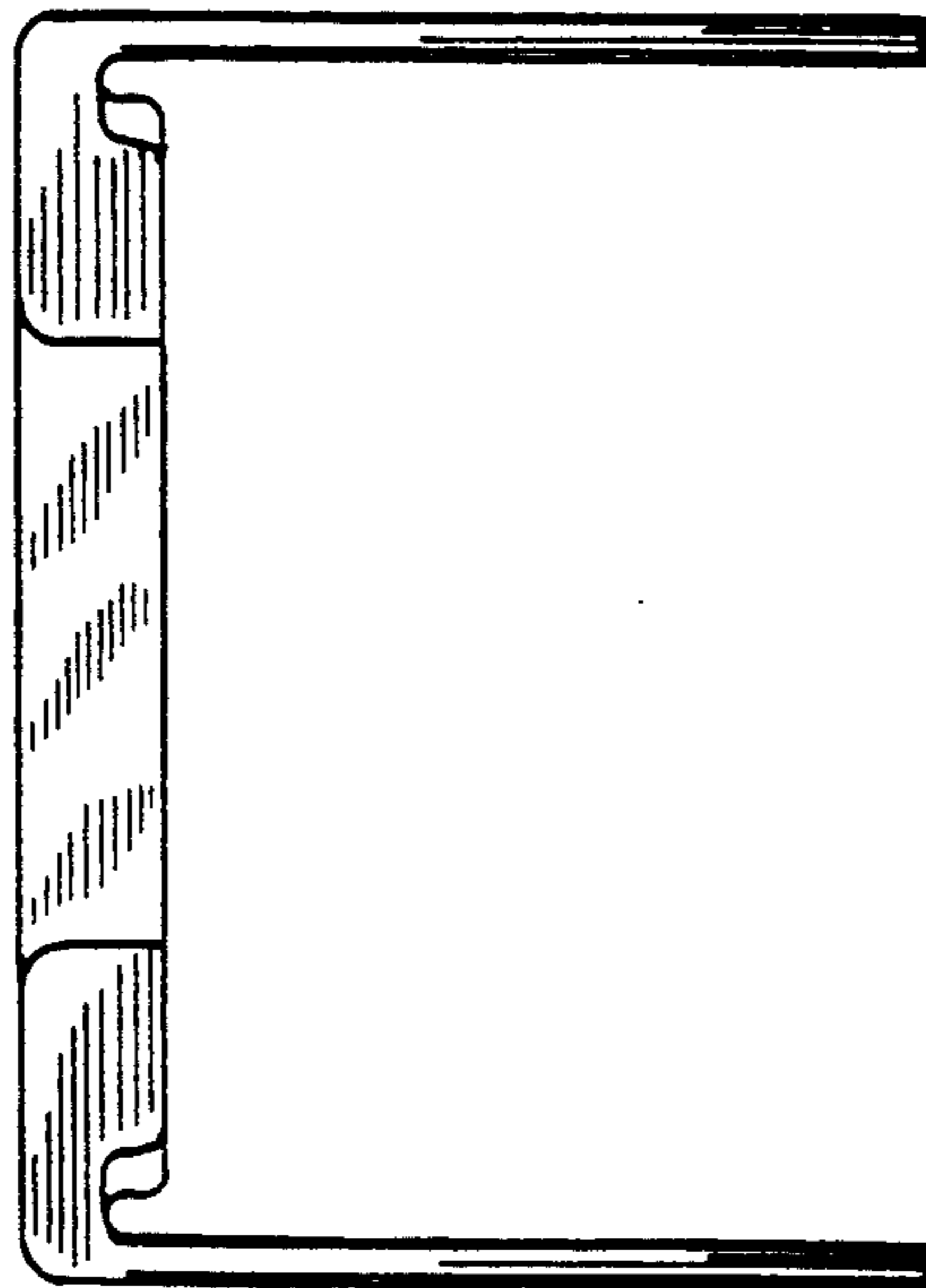

FIG. 3