



US00D340811S

# United States Patent [19] Vaughan

[11] Patent Number: **Des. 340,811**

[45] Date of Patent: **\*\* Nov. 2, 1993**

[54] PICTURE FRAME

[76] Inventor: **Peter R. Vaughan**, Flat 10, Hillcliffe Court 95-97 South Promenade, St. Annes Lancs, United Kingdom

[\*\*] Term: **14 Years**

[21] Appl. No.: **648,440**

[22] Filed: **Jan. 28, 1991**

[30] **Foreign Application Priority Data**

Jul. 28, 1990 [GB] United Kingdom ..... 2008620

[52] U.S. Cl. .... **D6/310**

[58] Field of Search ..... D6/300-314;  
40/152, 152.1, 154

[56] **References Cited**

**U.S. PATENT DOCUMENTS**

D. 278.865	5/1985	McCaffrey	.....	D6/311
D. 306.659	3/1990	Mercandante	.....	D6/300
D. 311.820	11/1990	Glucksman et al.	.....	D6/308
1.669.895	5/1928	Blyth	.....	40/152.1
4.258.489	3/1981	Maguire	.....	40/152.1

**FOREIGN PATENT DOCUMENTS**

0630500 10/1949 United Kingdom ..... 40/152.1

*Primary Examiner*—Melvin B. Feifer  
*Assistant Examiner*—Adir Aronovich  
*Attorney, Agent, or Firm*—Townsend and Townsend  
Khourie and Crew

[57] **CLAIM**

The ornamental design for a picture frame, as shown and described.

**DESCRIPTION**

FIG. 1 is a front elevational view of a picture frame showing my new design;  
FIG. 2 is a rear elevational view thereof, the stand shown in a folded position;  
FIG. 3 is a top plan view thereof;  
FIG. 4 is a side elevational view thereof, the stand shown in an extended position;  
FIG. 5 is an enlarged fragmentary sectional view taken along line 5—5 of FIG. 2;  
FIG. 6 is an enlarged fragmentary sectional view similar to that shown in FIG. 5 but with the stand shown in an extended position;  
FIG. 7 is a top, front perspective view thereof; and,  
FIG. 8 is a bottom plan view thereof.  
The broken line showing of reinforcing ribs, mounting hole and the base of the stand is for illustrative purposes only and forms no part of the claimed design.

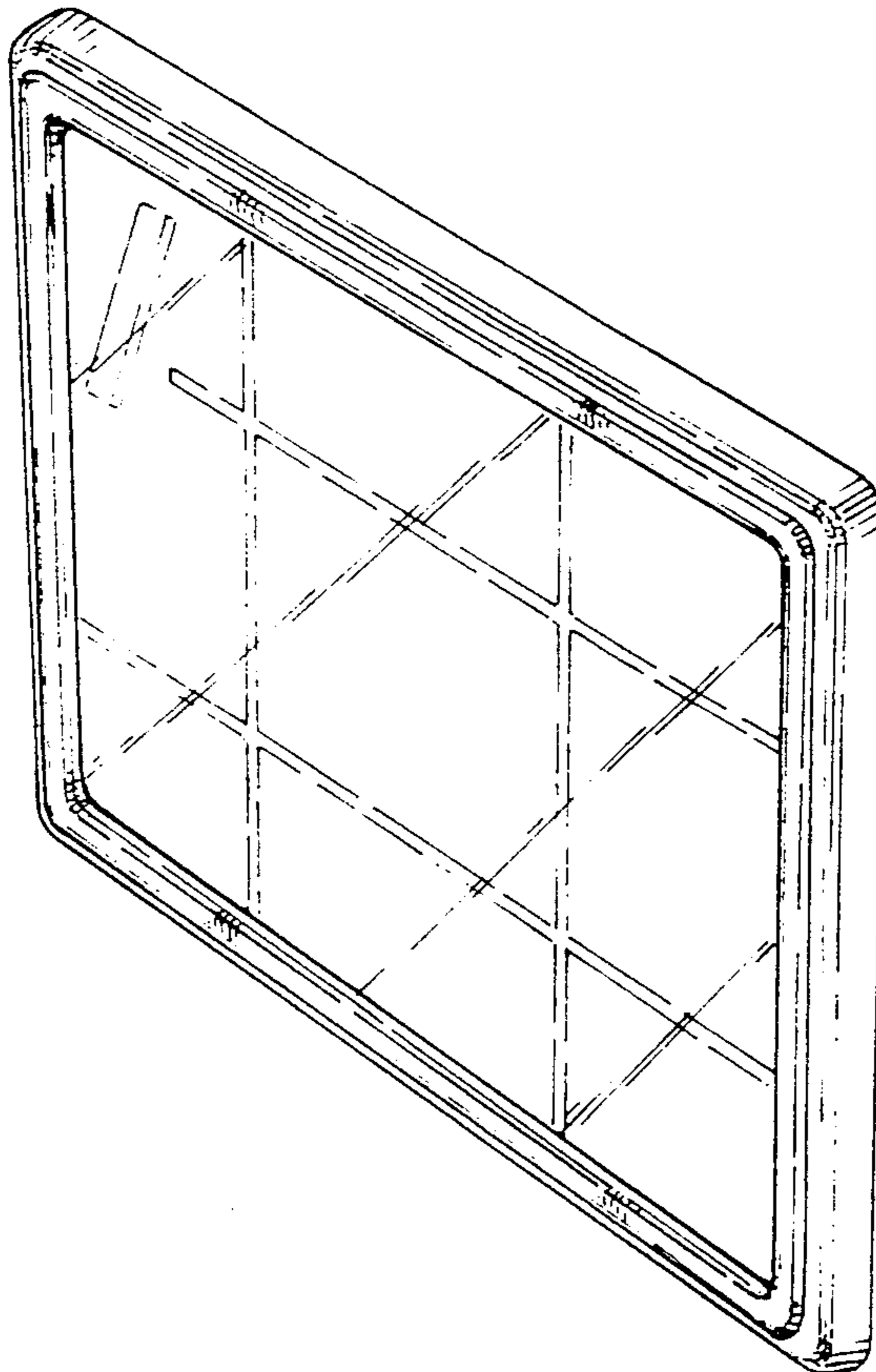

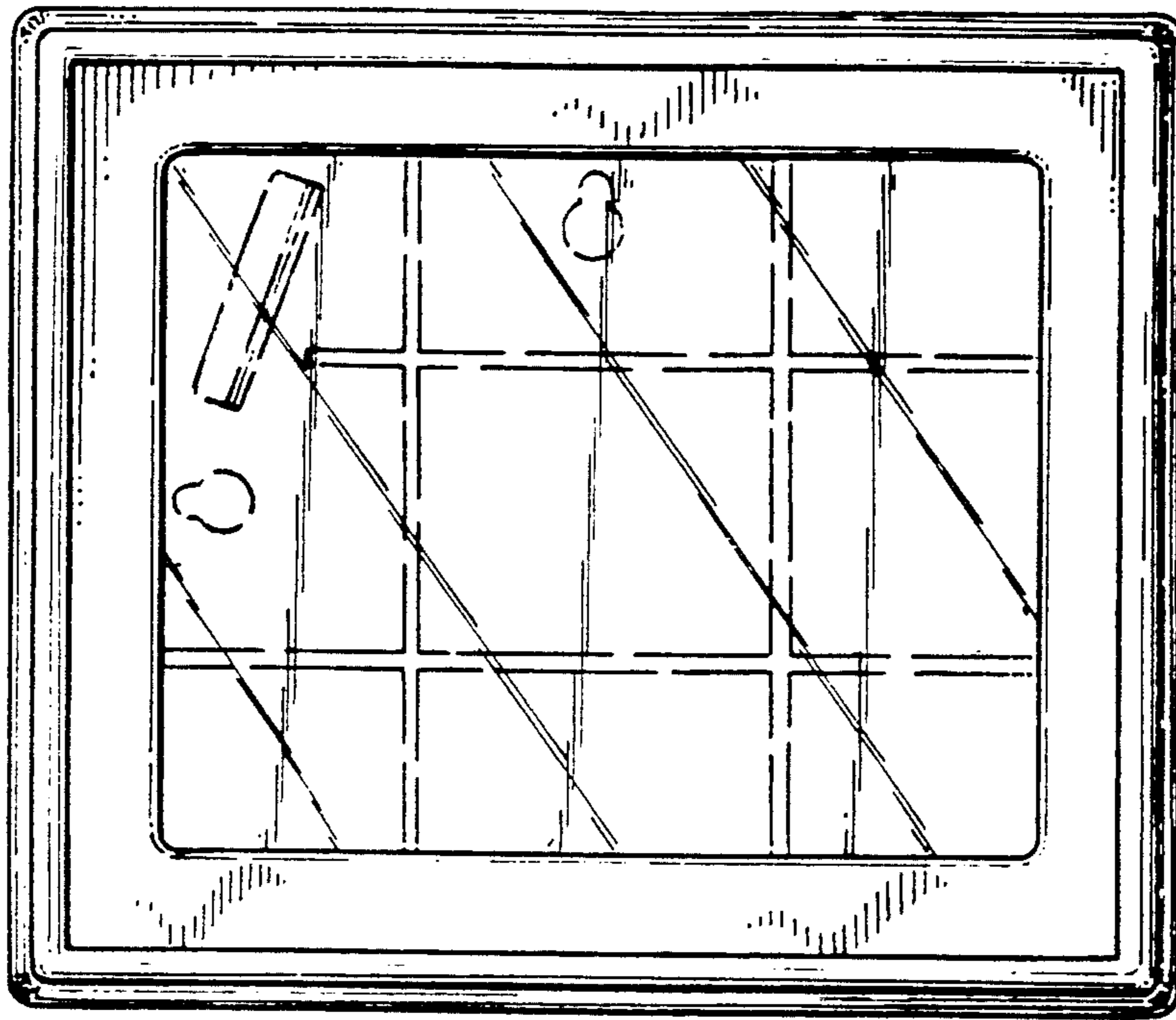

**FIG. 1**

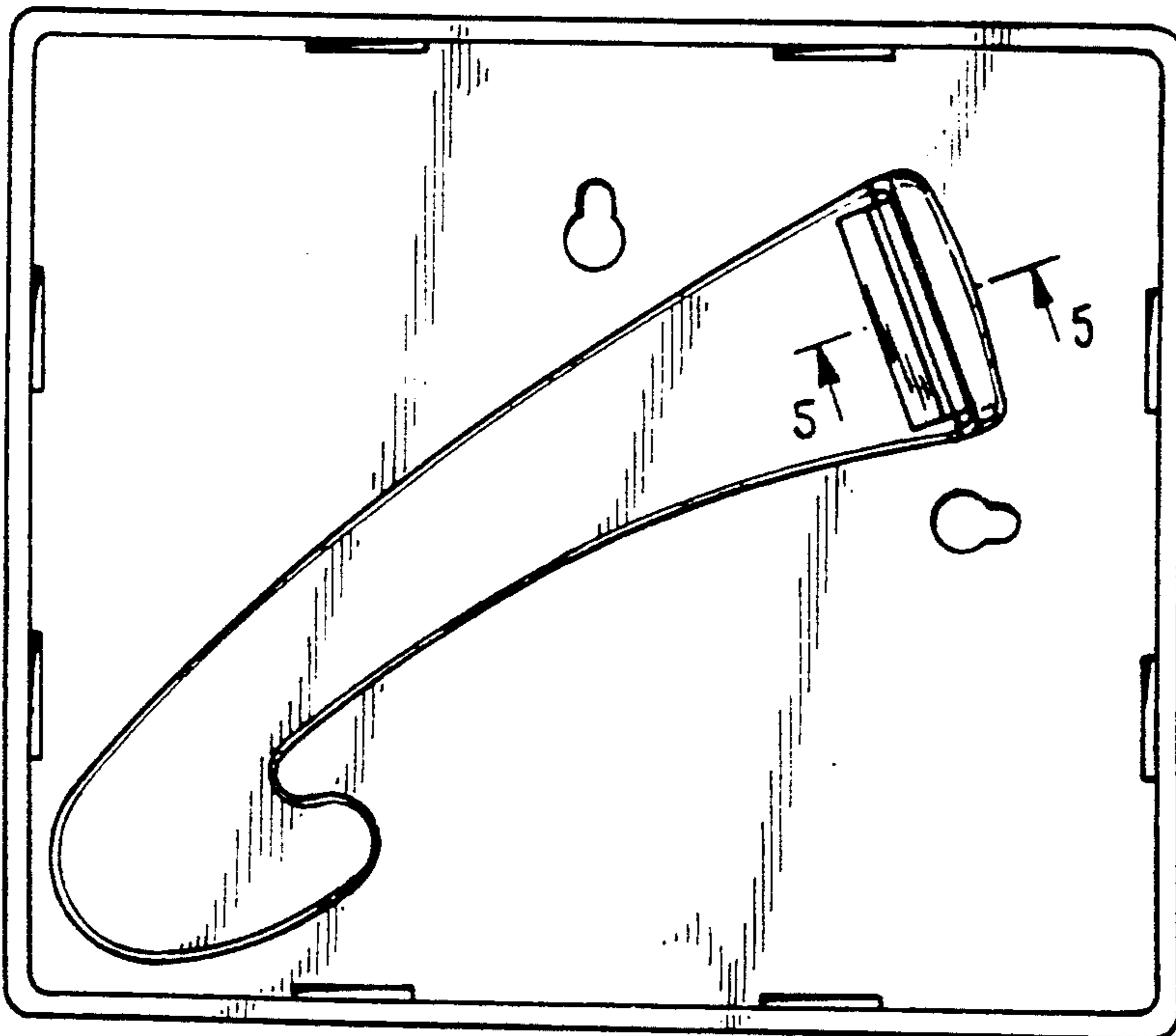

**FIG. 2**

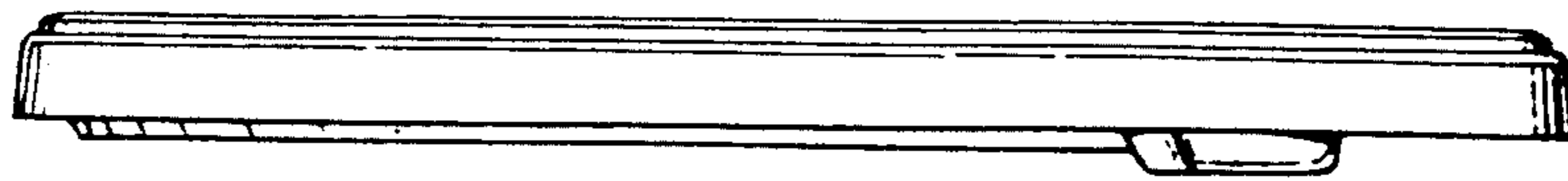

FIG. 3

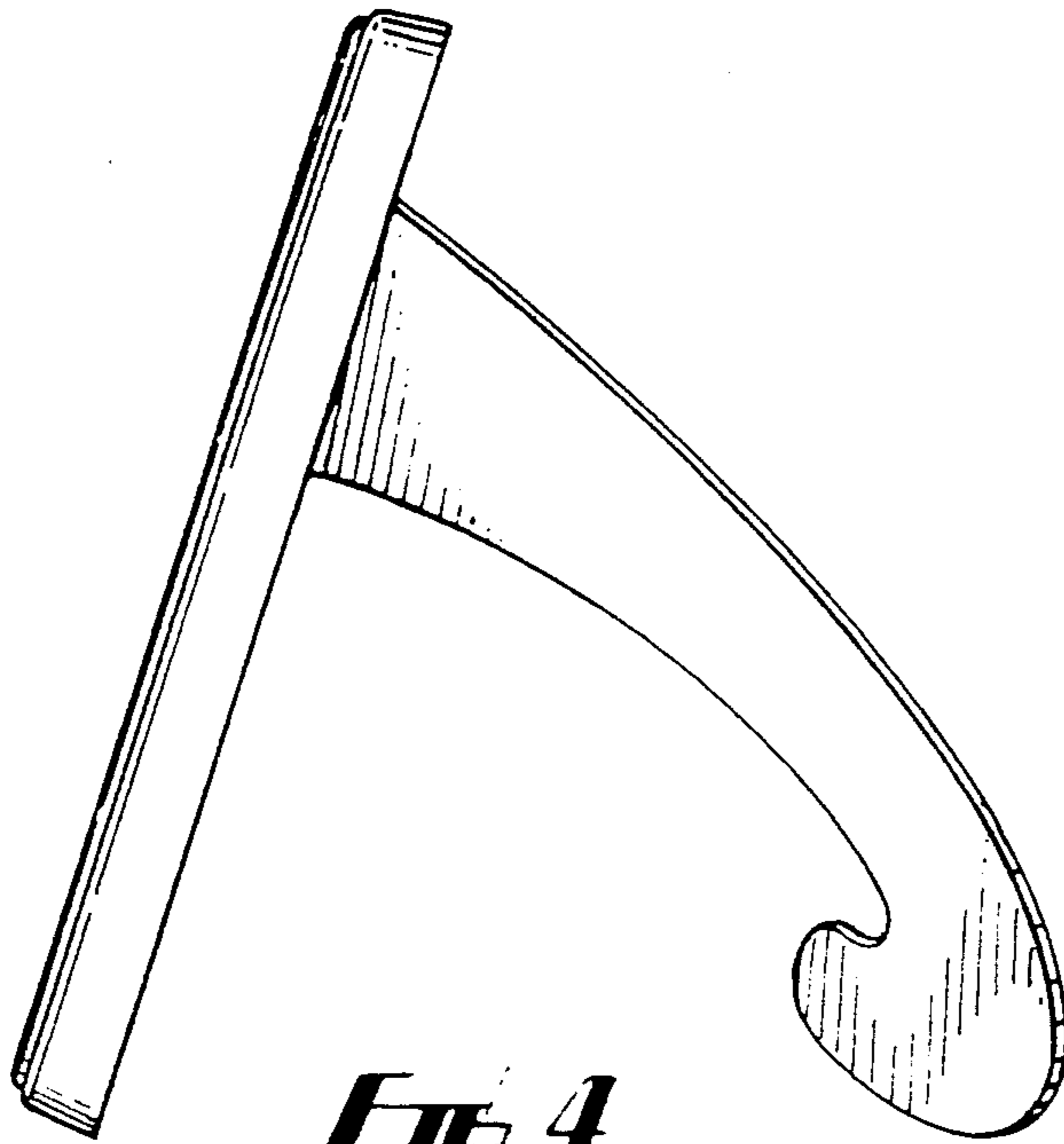

FIG. 4

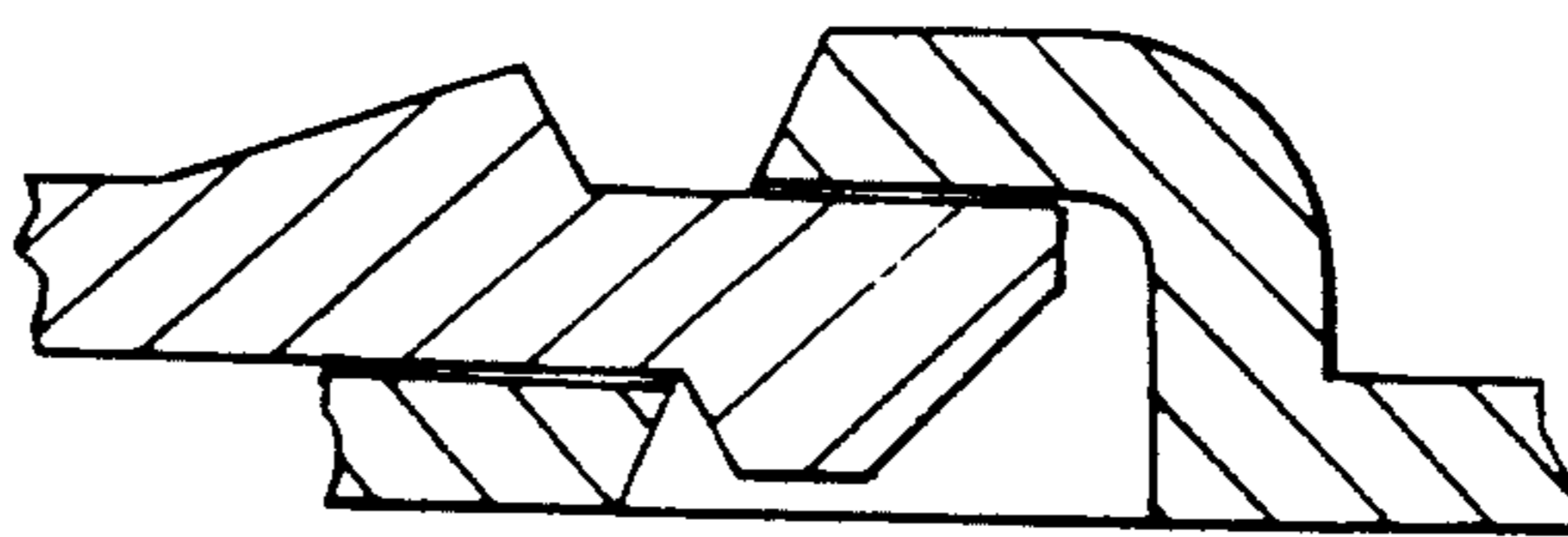

FIG. 5

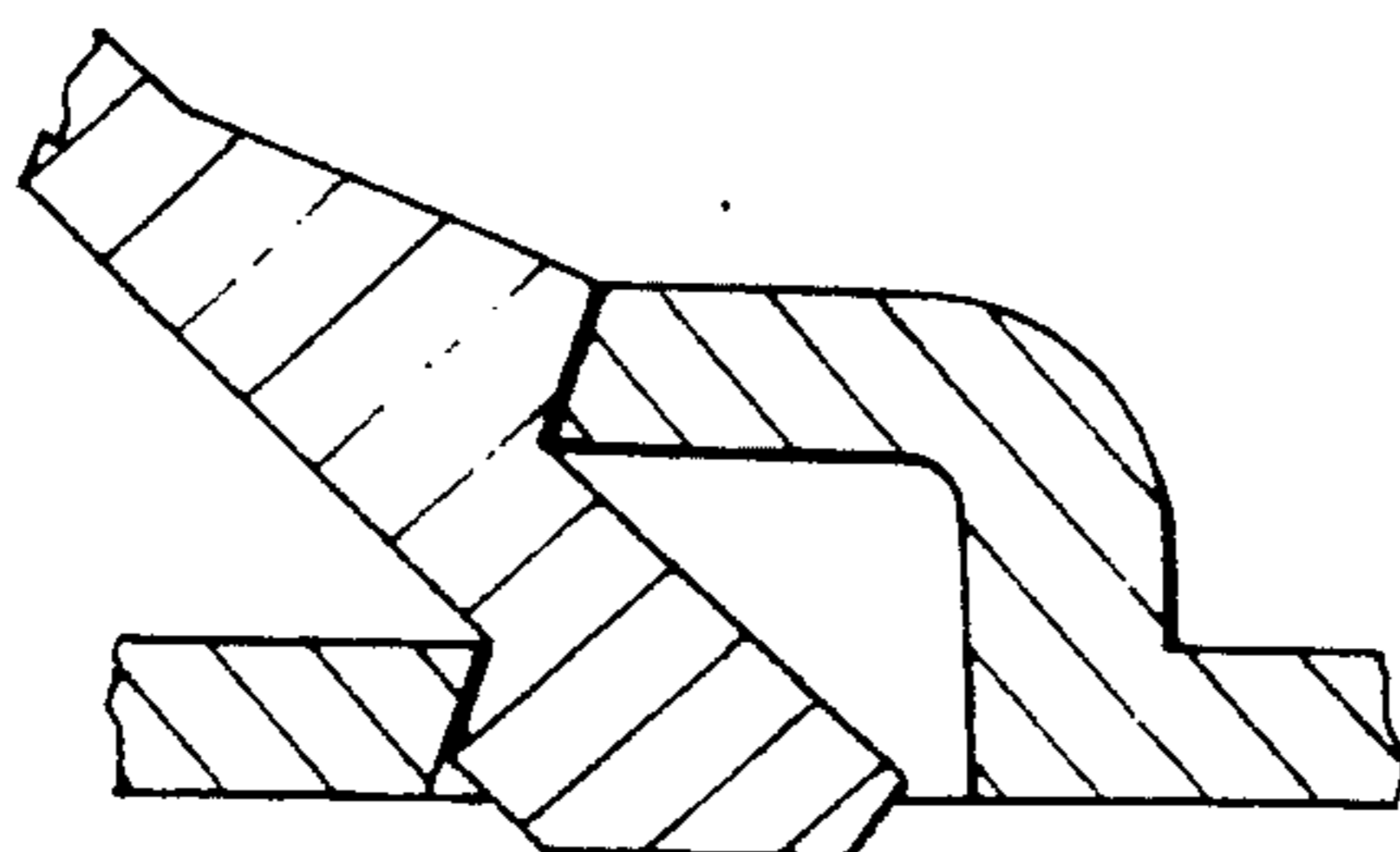

FIG. 6

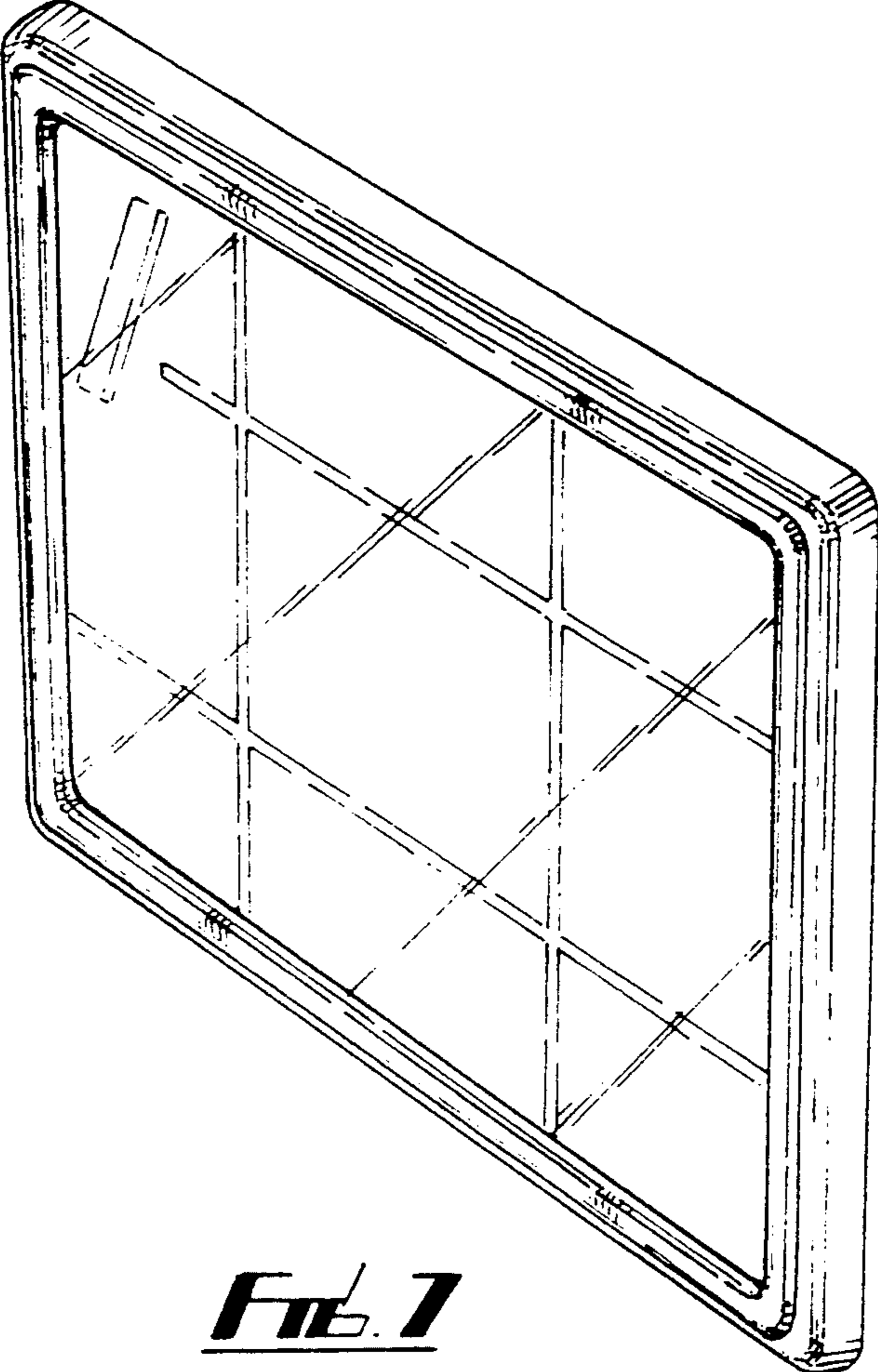

FIG. 7

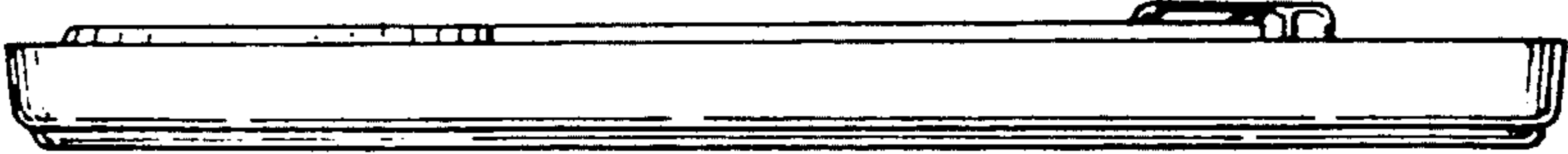

FIG. 8