



US00D340513S

United States Patent [19]

[11] Patent Number: **Des. 340,513**

Stahel, II et al.

[45] Date of Patent: **** Oct. 19, 1993**

[54] **MOTORCYCLE AIR CLEANER**

[75] Inventors: **Alwin J. Stahel, II, St. Paul, Minn.;**
Thomas H. Rudd, Hudson, Wis.

[73] Assignee: **KuryAkyn Holdings, Inc., Hudson, Wis.**

[**] Term: **14 Years**

[21] Appl. No.: **843,380**

[22] Filed: **Feb. 28, 1992**

[52] U.S. Cl. **D23/364; D12/114;**
D15/5

[58] Field of Search **D12/114; 123/198 E,**
123/389, 442; 261/23.2; 55/497, 498

[56] **References Cited**

U.S. PATENT DOCUMENTS

D. 305,149	12/1989	Stahel	D23/364
D. 328,343	7/1992	Cheny	D23/264
4,008,700	2/1977	Pierlot	123/442
4,268,289	5/1981	Polaner	55/497
4,425,145	1/1984	Reese	55/497
4,594,083	6/1986	Hiraizumi	55/498
4,783,207	11/1988	Nagashima et al.	55/498
5,120,334	6/1992	Cooper	55/497

OTHER PUBLICATIONS

American Motorcycles, pp. 165-166, Chrome Specialties 1991/1992.

Specialty Parts & Accessories, Fall/Winter 1991, p. 353, The Street Scoop II.

Primary Examiner—Wallace R. Burke
Assistant Examiner—Melody Brown
Attorney, Agent, or Firm—Kinney & Lange

[57] **CLAIM**

The ornamental design for a motorcycle air cleaner, as shown and described.

DESCRIPTION

FIG. 1 is a view in perspective as seen from the top, front and one side of a motorcycle air cleaner showing our new design;

FIG. 2 is a view in top plan;

FIG. 3 is a view in bottom plan thereof;

FIG. 4 is a view in side elevation as seen from bottom to top of FIG. 2 thereof;

FIG. 5 is a view in side elevation as seen from the side opposite that shown in FIG. 4 thereof;

FIG. 6 is a view in rear elevation thereof;

FIG. 7 is a view in front elevation thereof;

FIG. 8 is a view in perspective as seen from the top, front and one side with the inlet doors in an alternate position;

FIG. 9 is a view in perspective as seen from the top, front and one side of a motorcycle air cleaner showing a second embodiment of our new design; wherein the only difference resides in the omission of the slot opening on the side of the design; and,

FIG. 10 is a view in side elevation of FIG. 9.

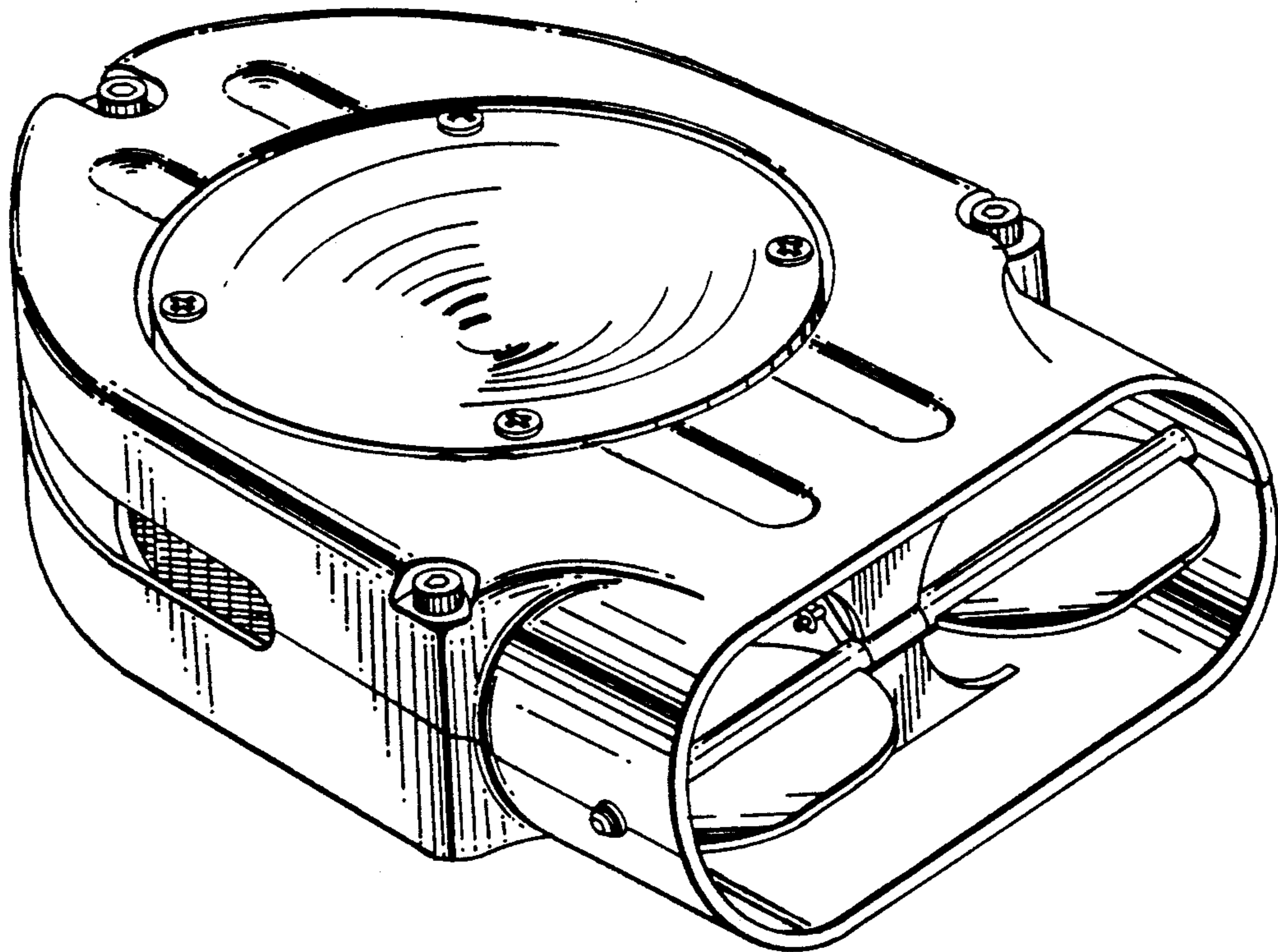

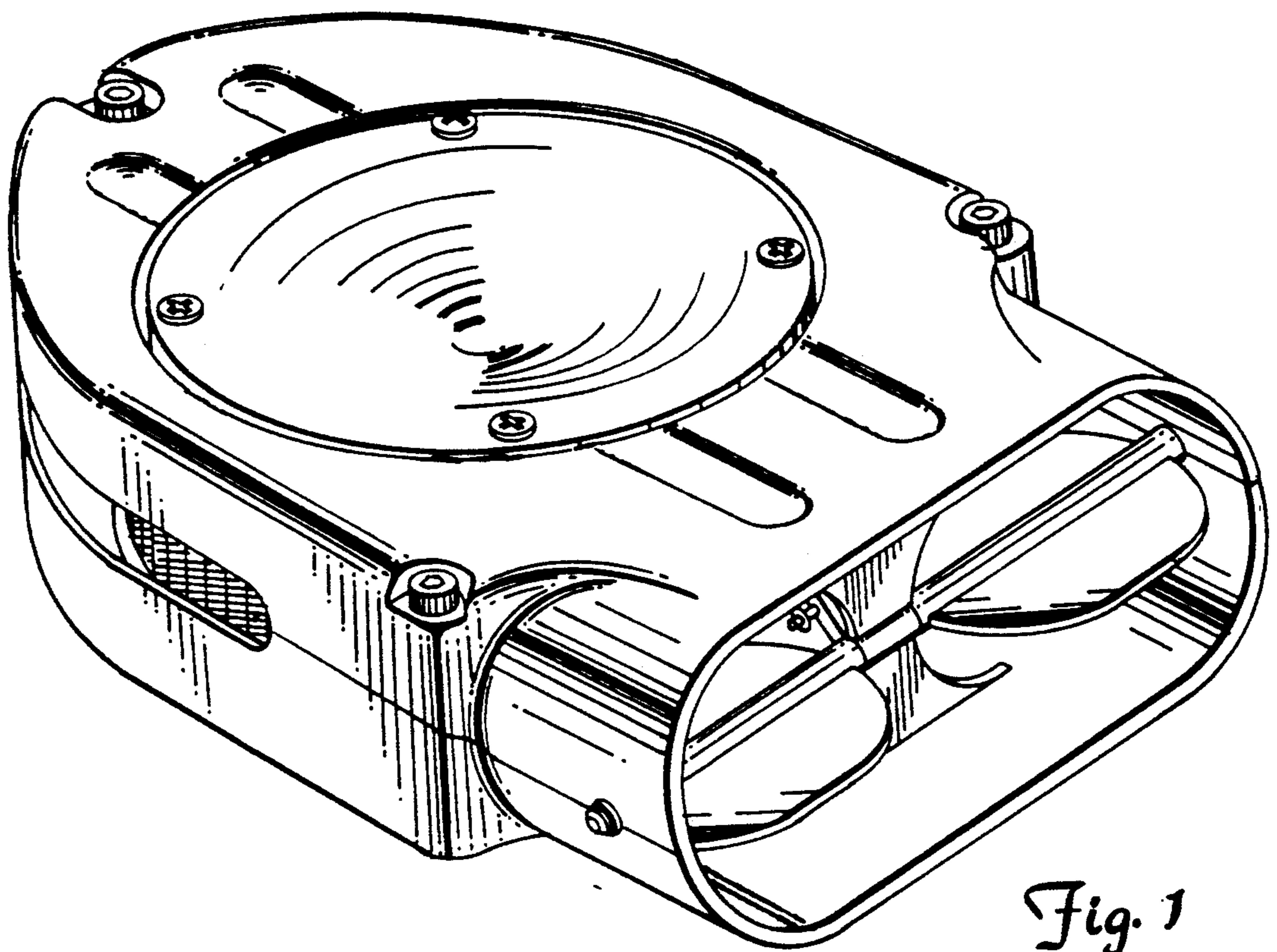

Fig. 1

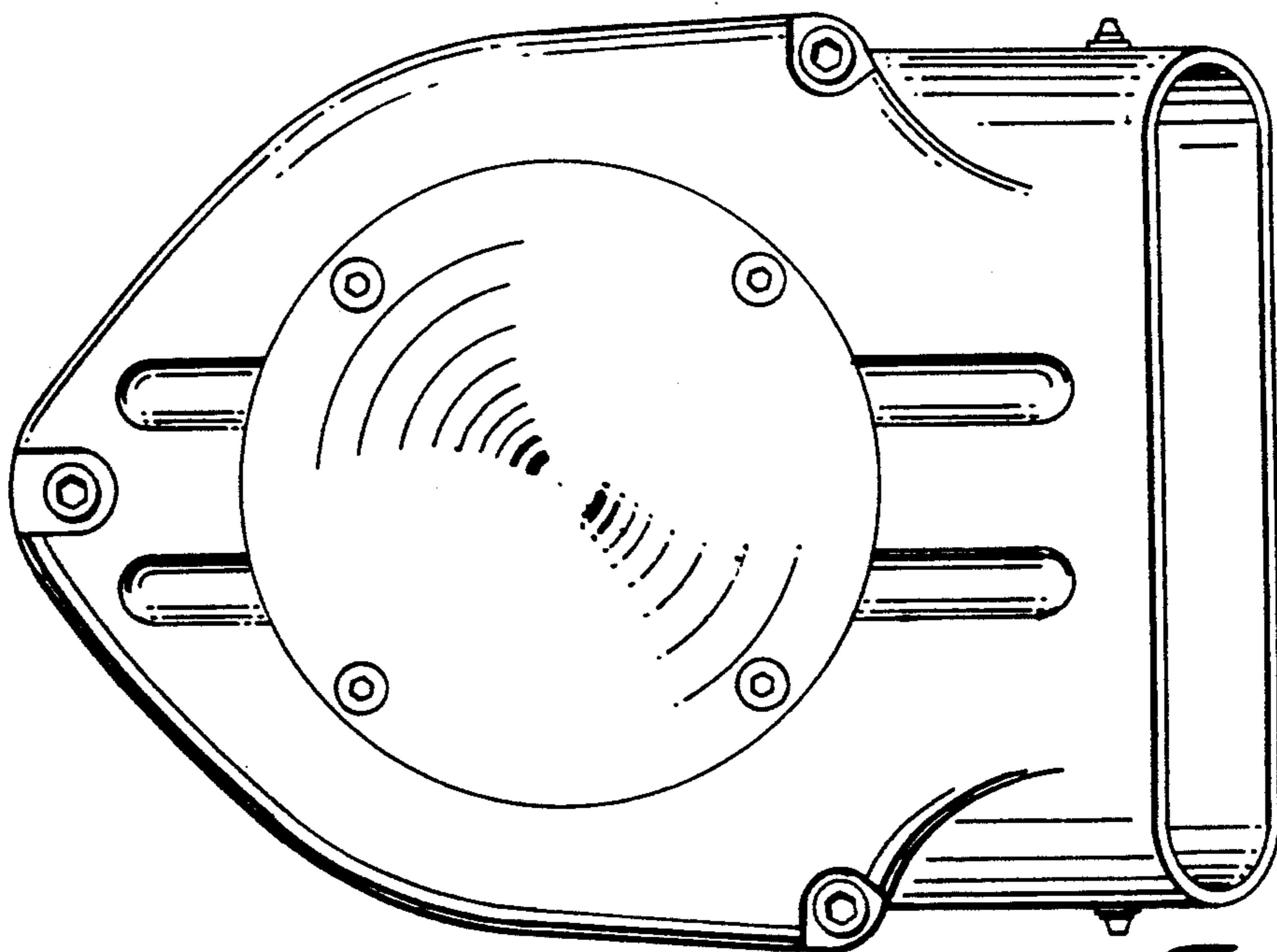
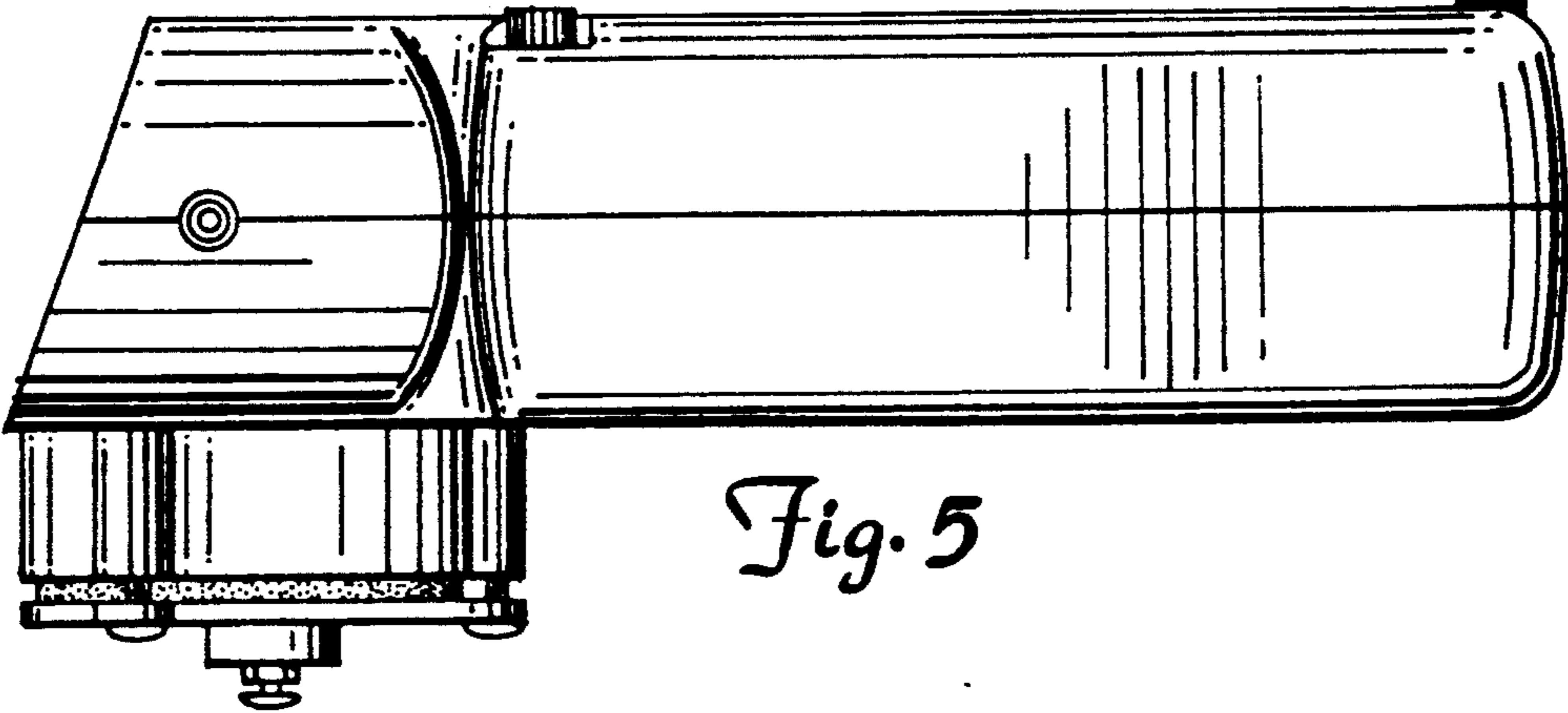
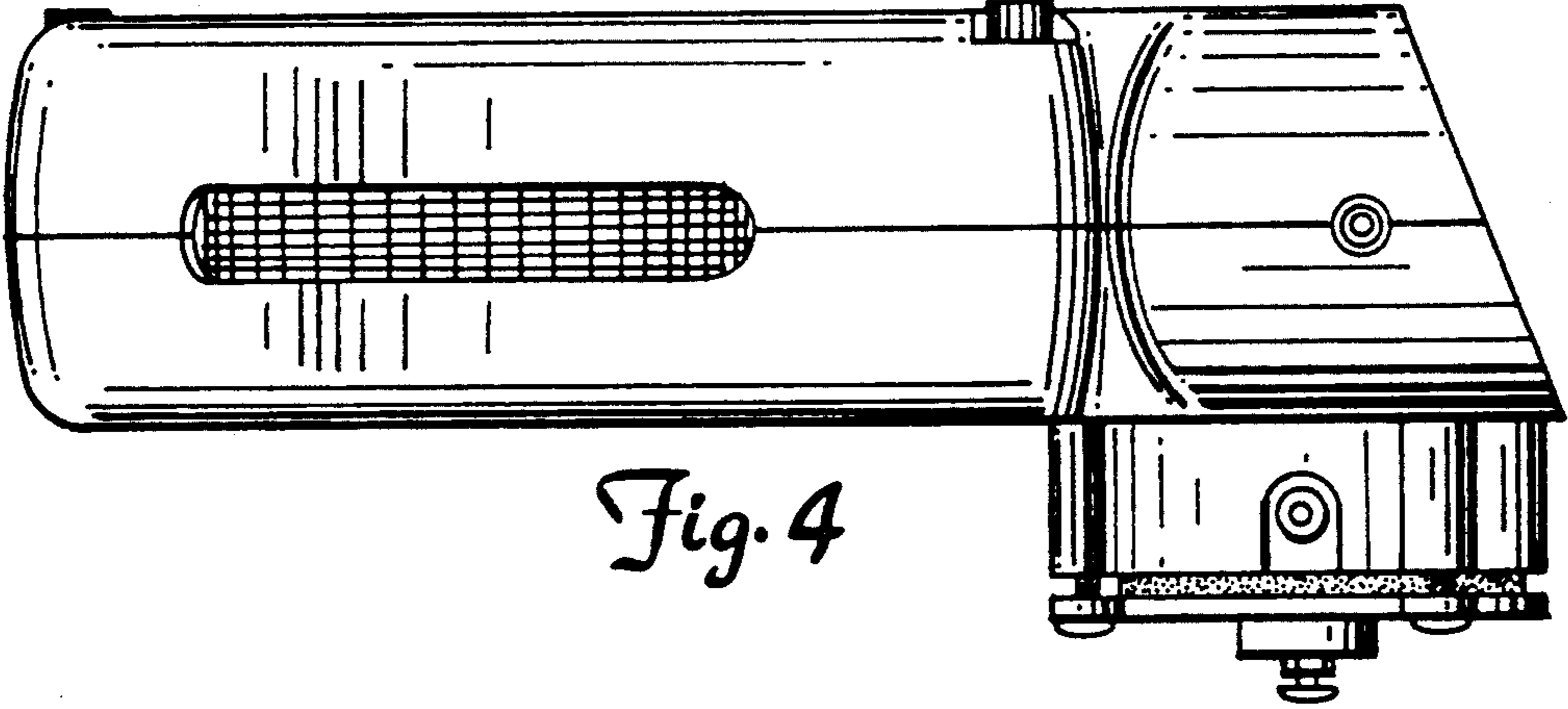
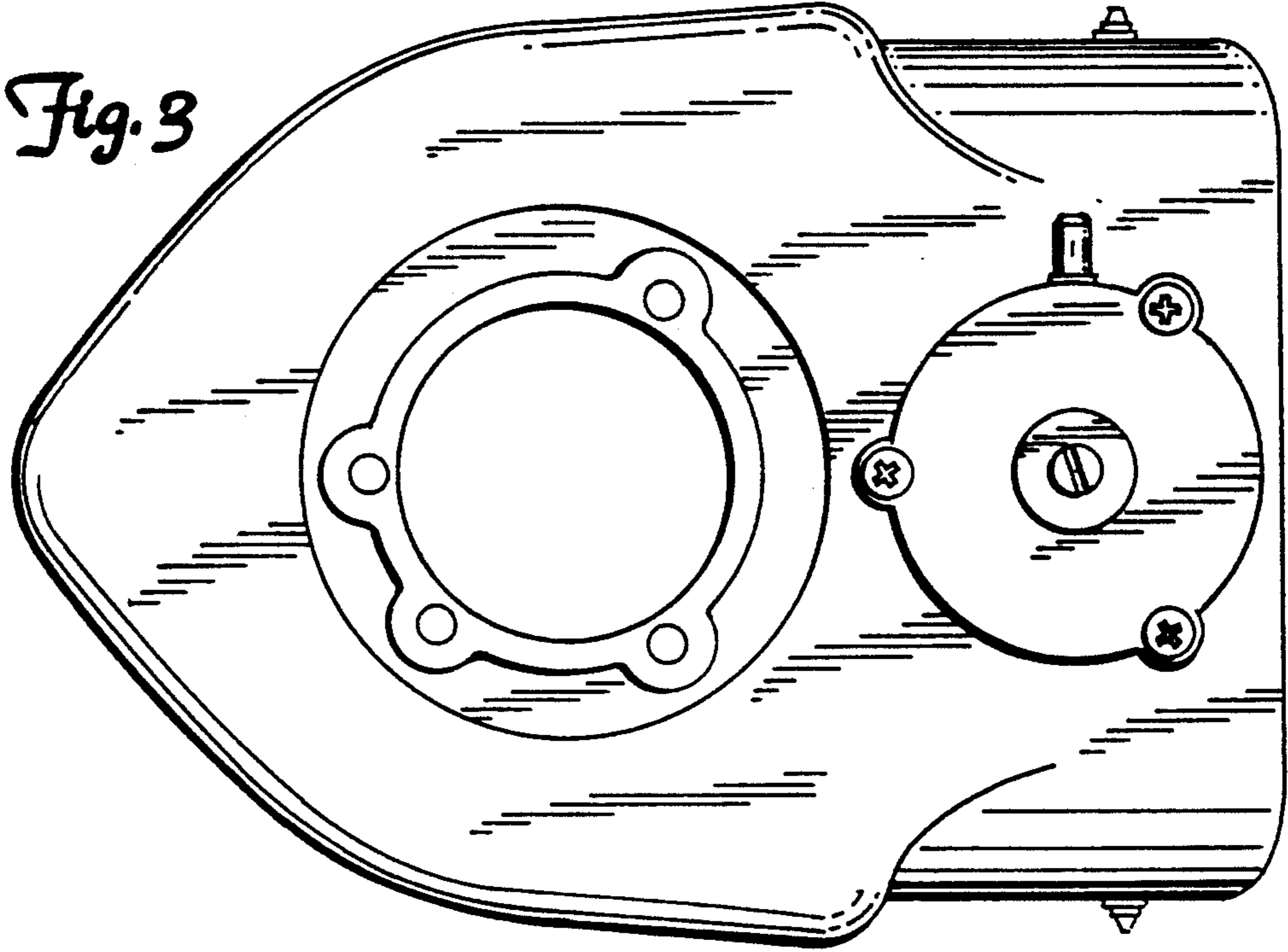

Fig. 2



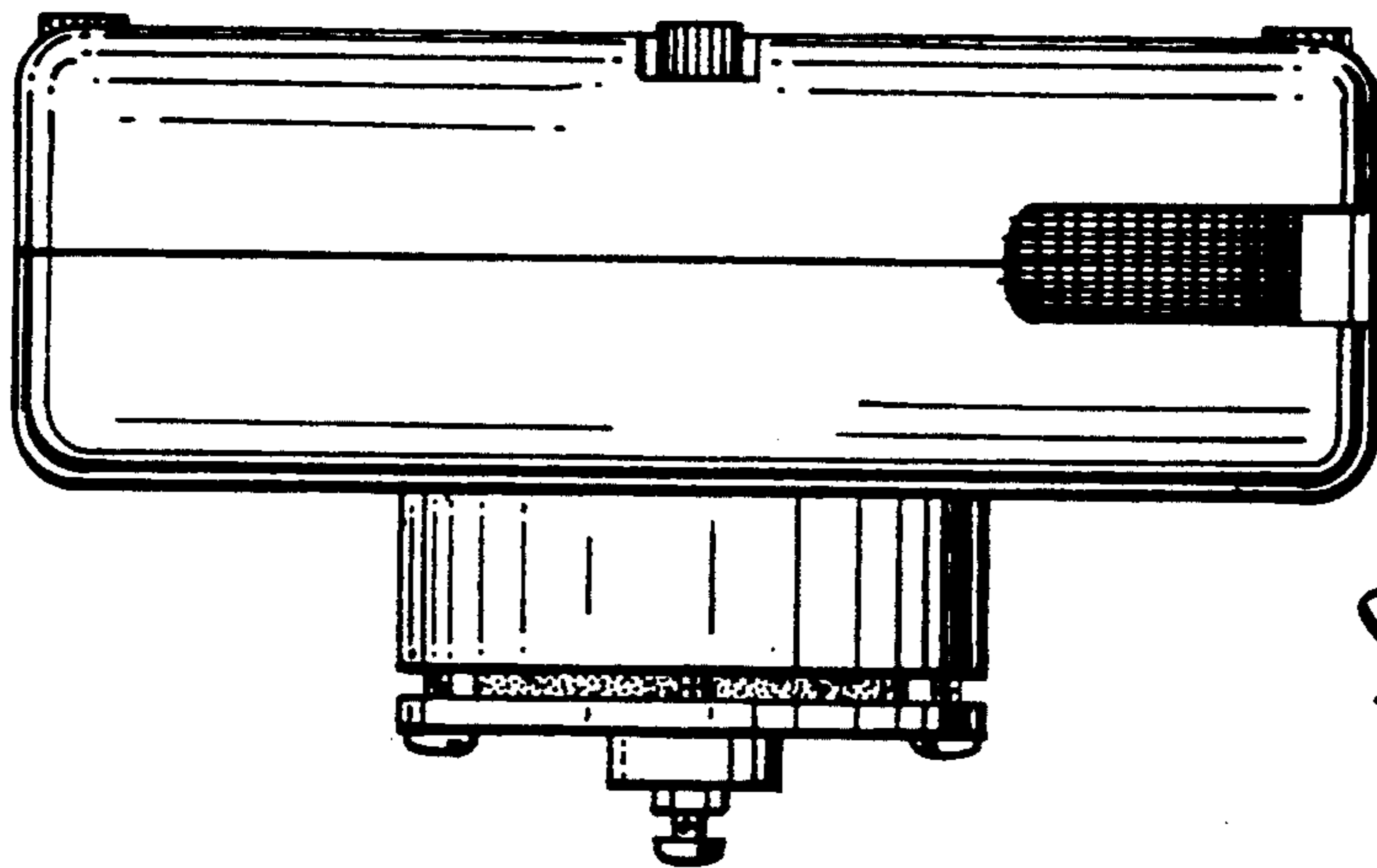

Fig. 6

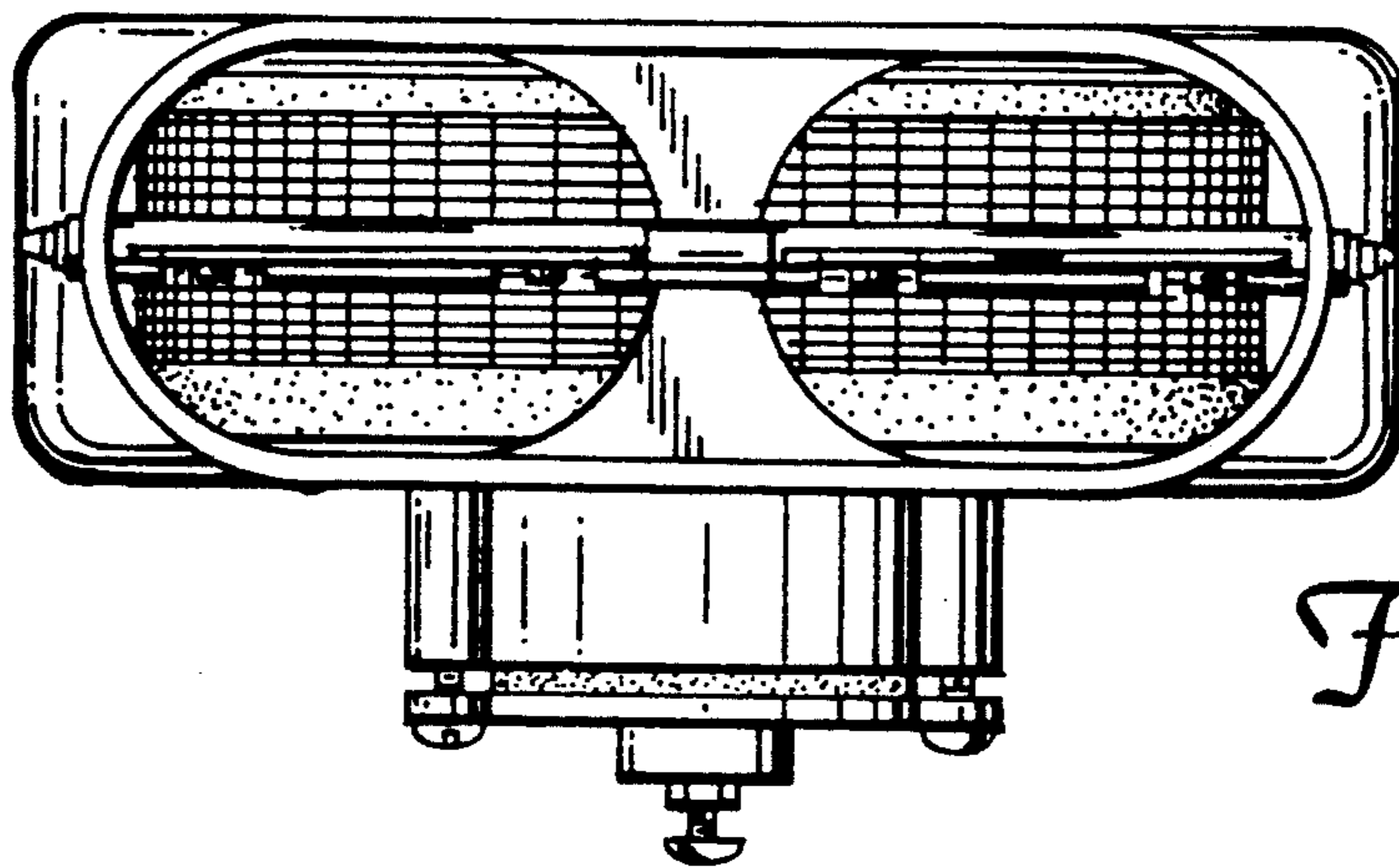

Fig. 7

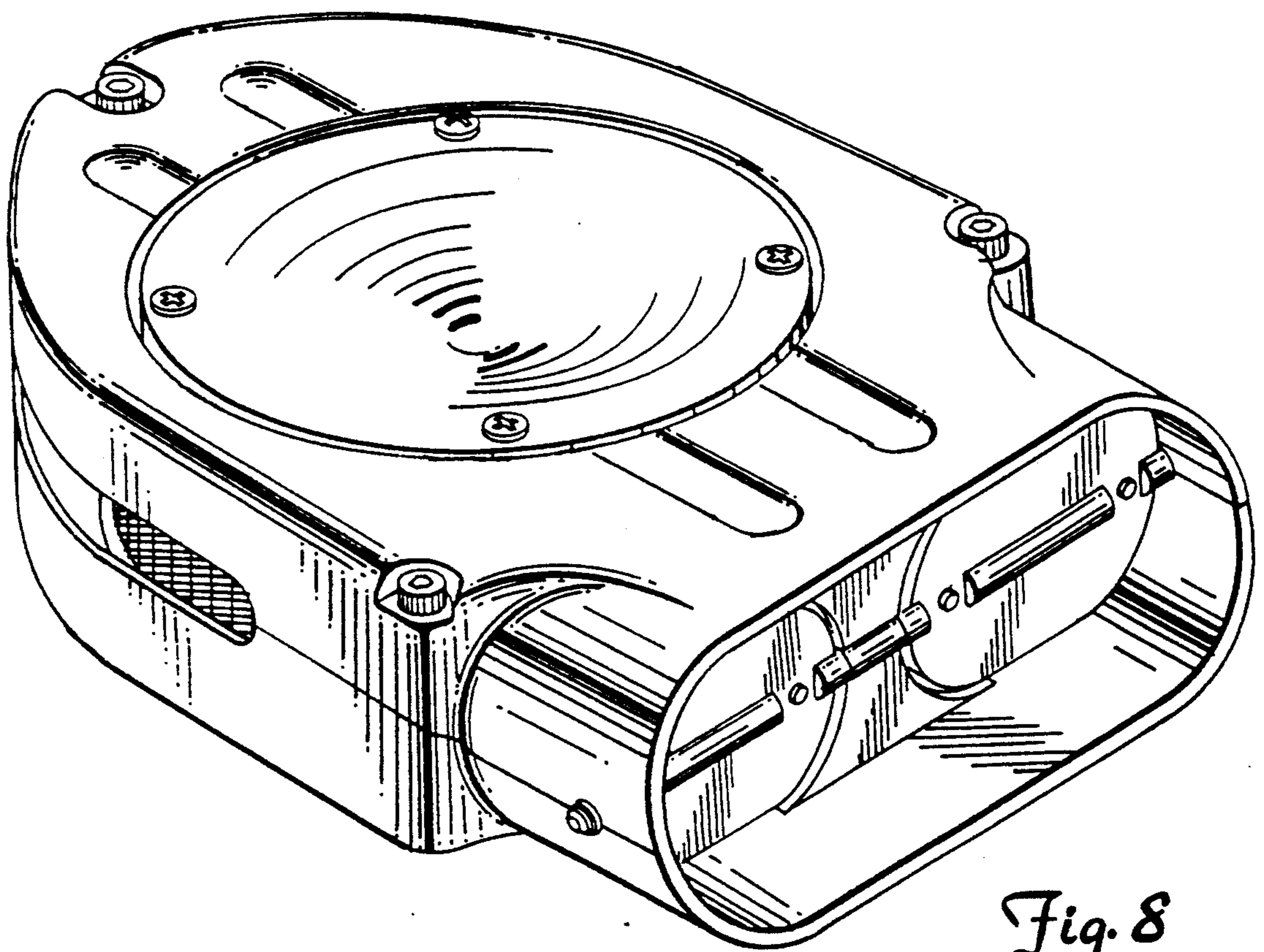

Fig. 8

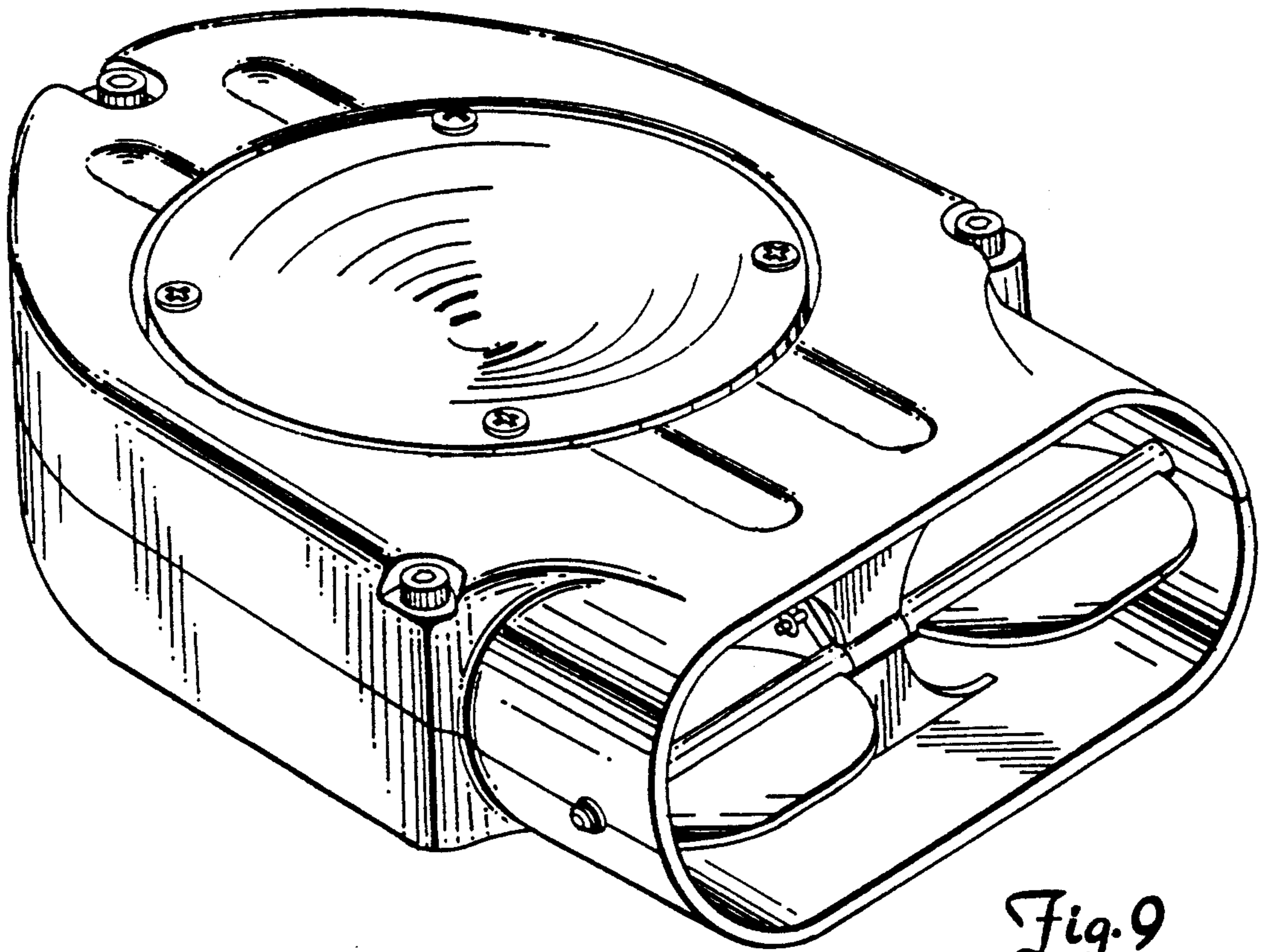

Fig. 9

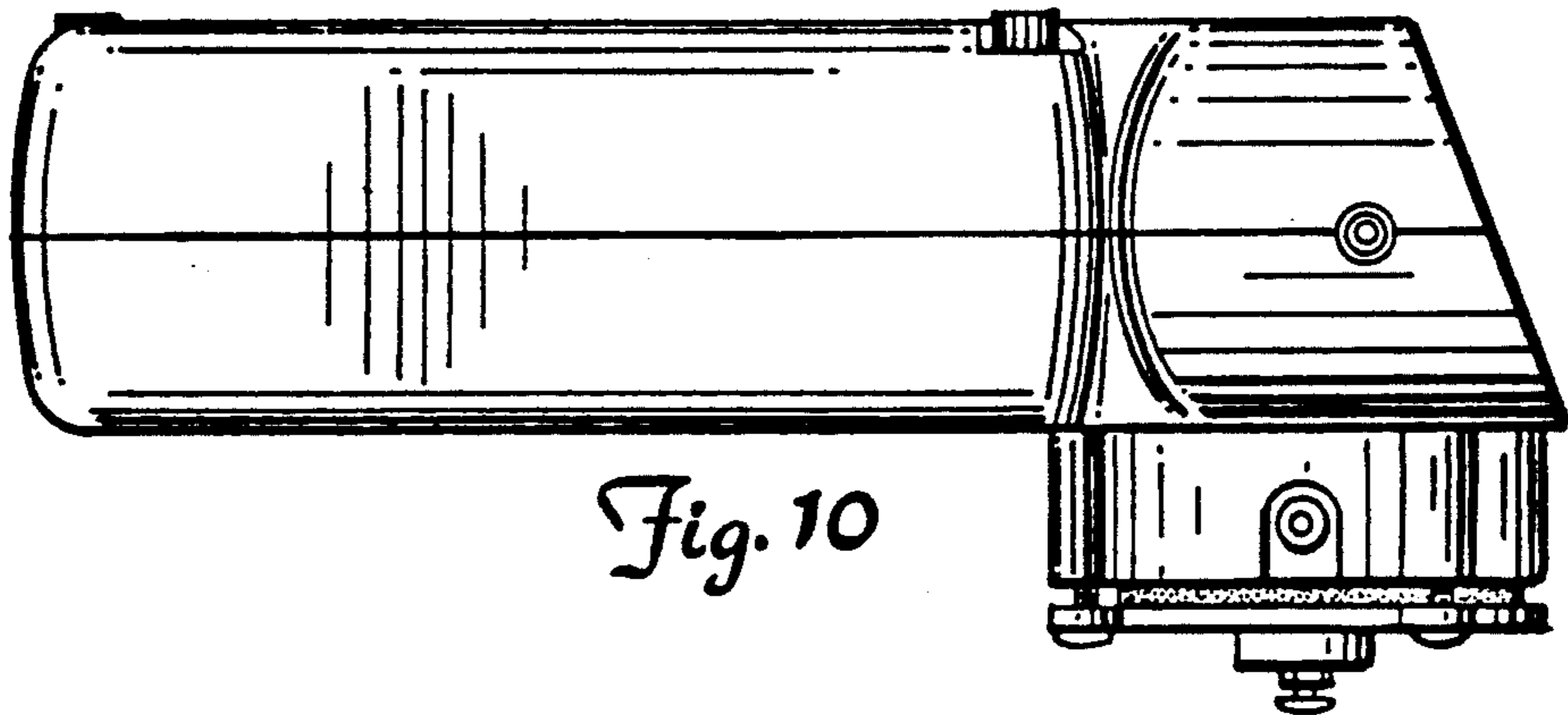

Fig. 10