



US00D340340S

United States Patent [19]

[11] Patent Number: **Des. 340,340**

Allen

[45] Date of Patent: **** Oct. 12, 1993**

[54] **RIDING TROWEL CRANKING DOLLY WHEEL ASSEMBLY**

4,710,055 12/1987 Maass et al. 404/112
5,088,799 2/1992 Redmon et al. 404/112

[75] Inventor: **J. Dewayne Allen, Paragould, Ark.**

Primary Examiner—Kay H. Chin
Attorney, Agent, or Firm—Stephen D. Carver; Jerry Mahurin

[73] Assignee: **Allen Engineering Corporation, Paragould, Ark.**

[57] **CLAIM**

[**] Term: **14 Years**

The ornamental design for a riding trowel cranking dolly wheel assembly, as shown and described.

[21] Appl. No.: **778,614**

DESCRIPTION

[22] Filed: **Oct. 18, 1991**

[52] U.S. Cl. **D34/28; D34/34; D34/23**

FIG. 1 is a rear elevational view of my riding trowel cranking dolly wheel assembly;
FIG. 2 is an end elevational view thereof, taken generally from the position to the right of FIG. 1;
FIG. 3 is a top plan view thereof;
FIG. 4 is an end elevational view, opposite that of FIG. 2;
FIG. 5 is a front elevational view thereof;
FIG. 6 is a front isometric view thereof; and,
FIG. 7 is a rear isometric view thereof.

[58] Field of Search **D34/34, 28, 23; 404/112**

[56] **References Cited**

U.S. PATENT DOCUMENTS

D. 288,912 3/1987 Lucas D34/34
2,983,203 5/1961 Fletcher 404/112

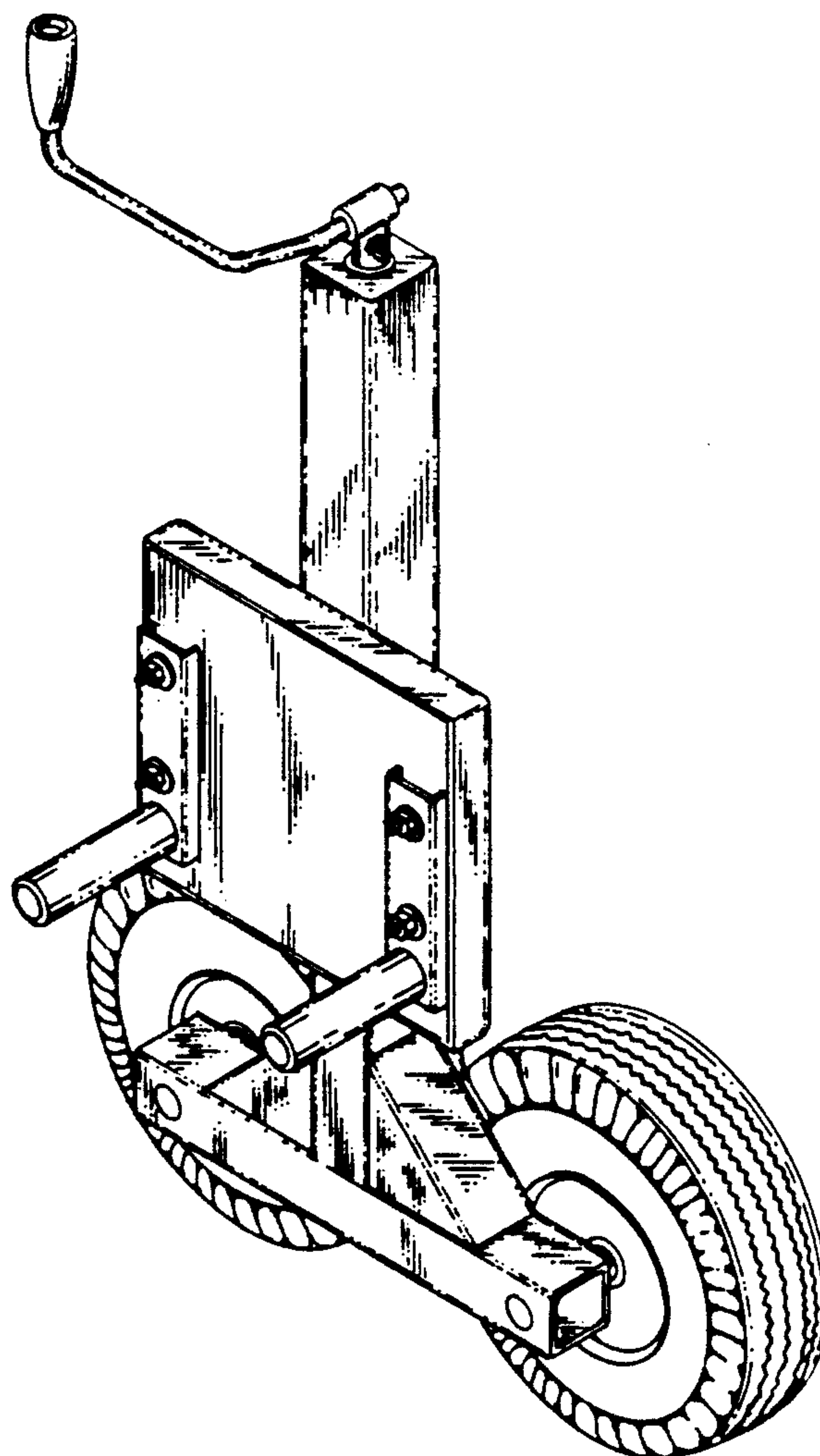

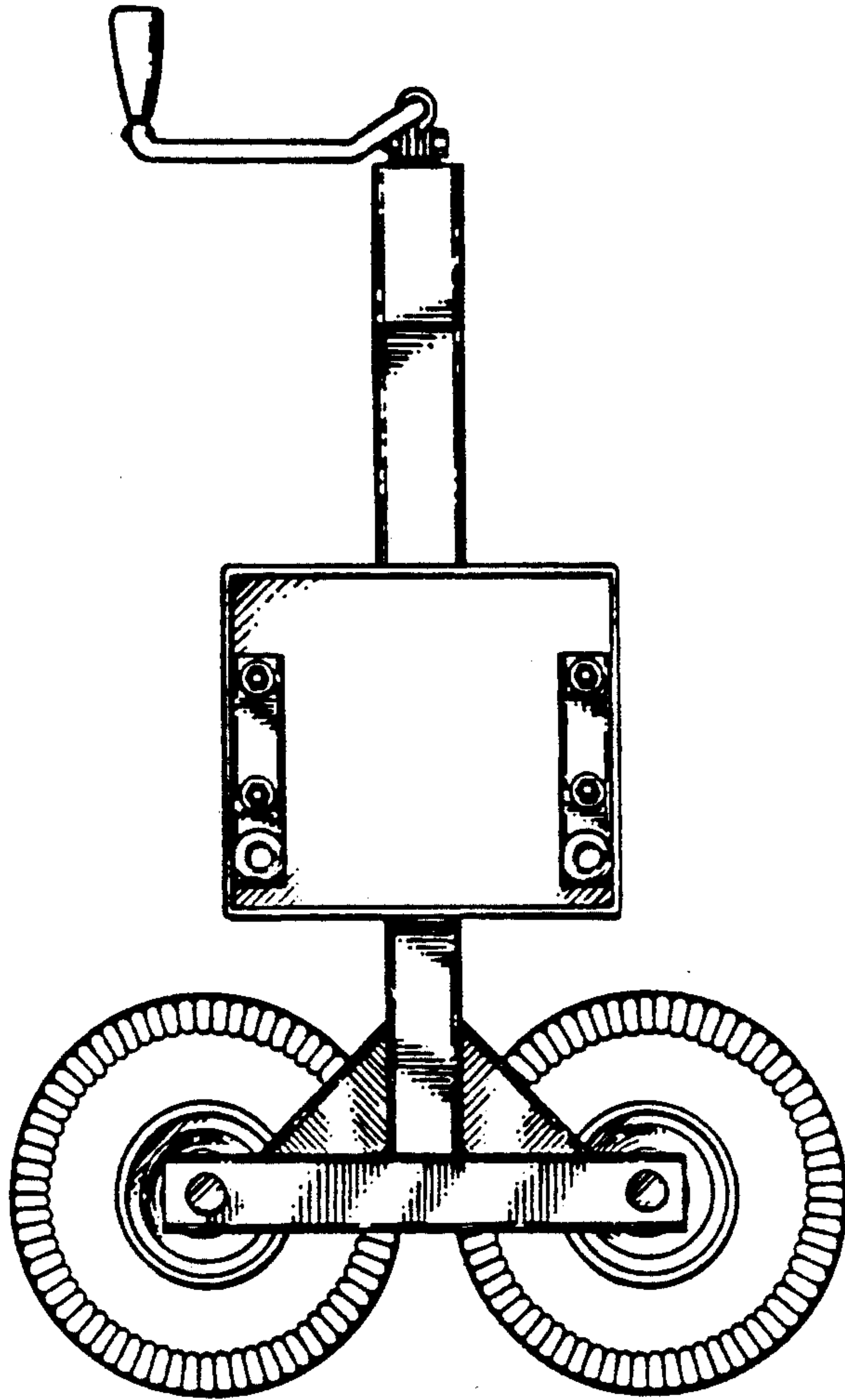

FIG. 1

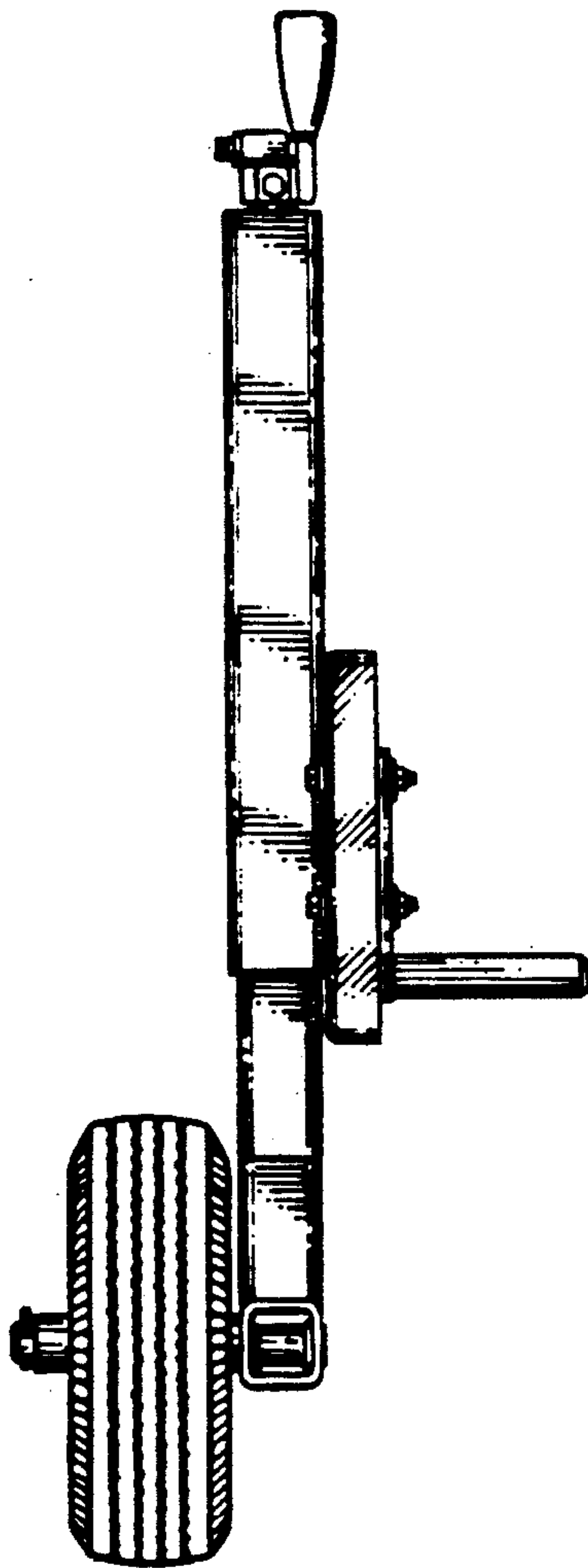

FIG. 2

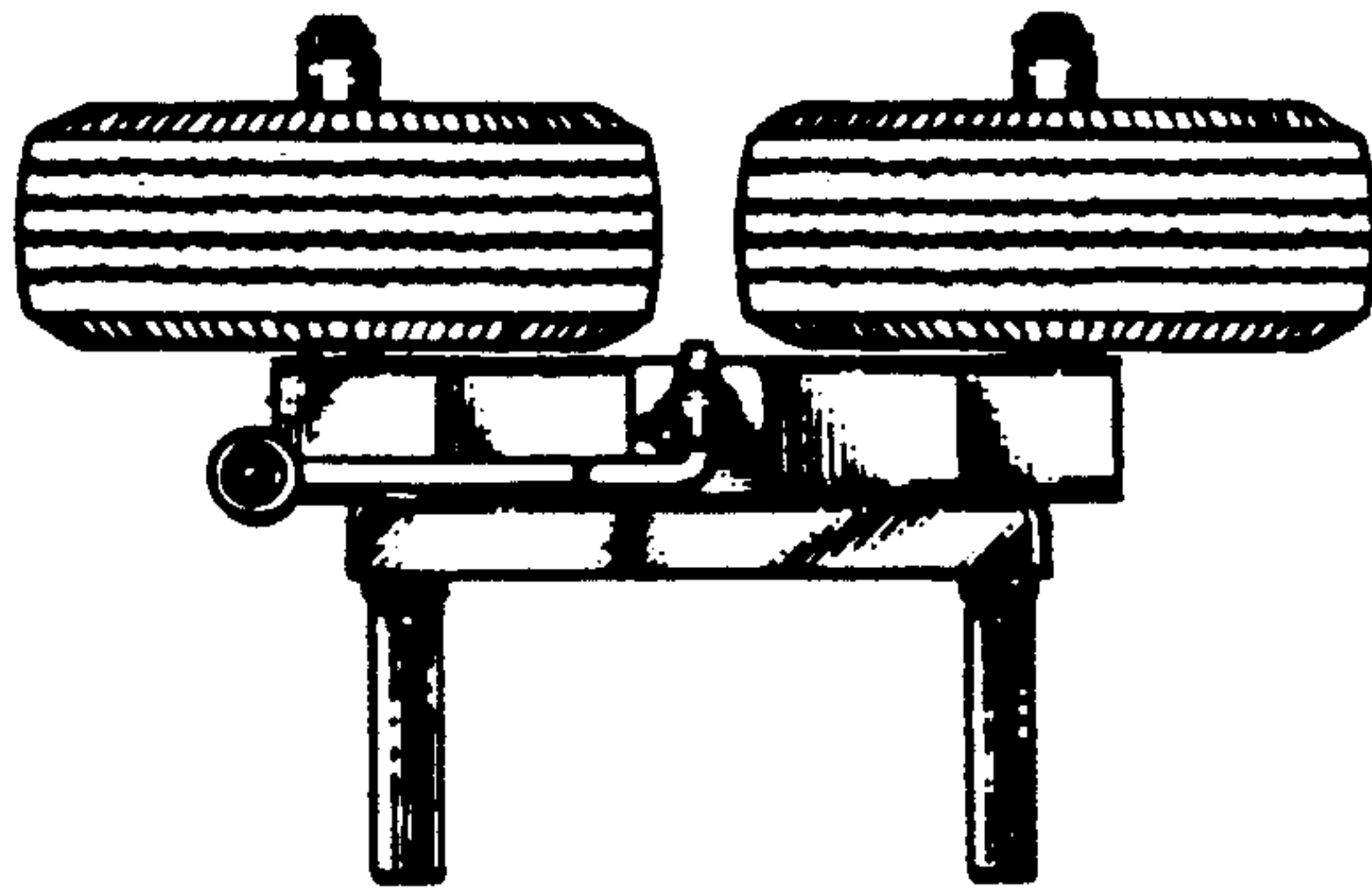

FIG. 3

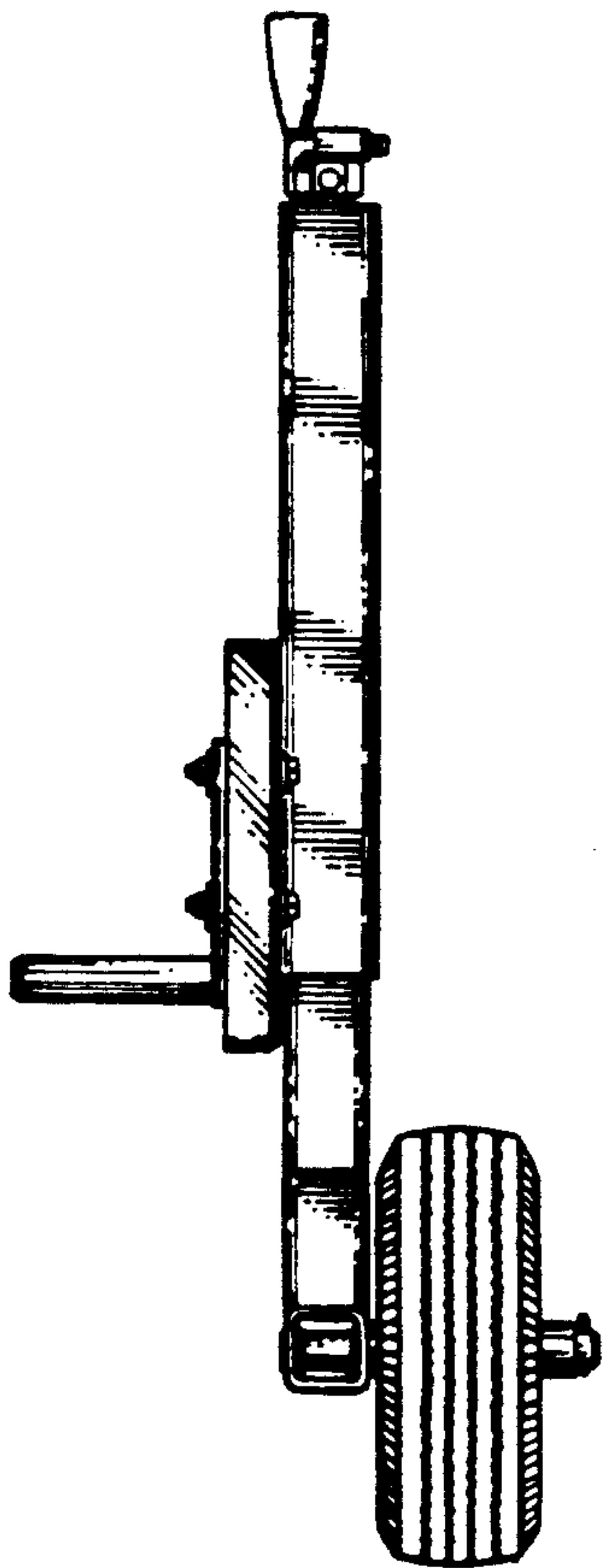

FIG. 4

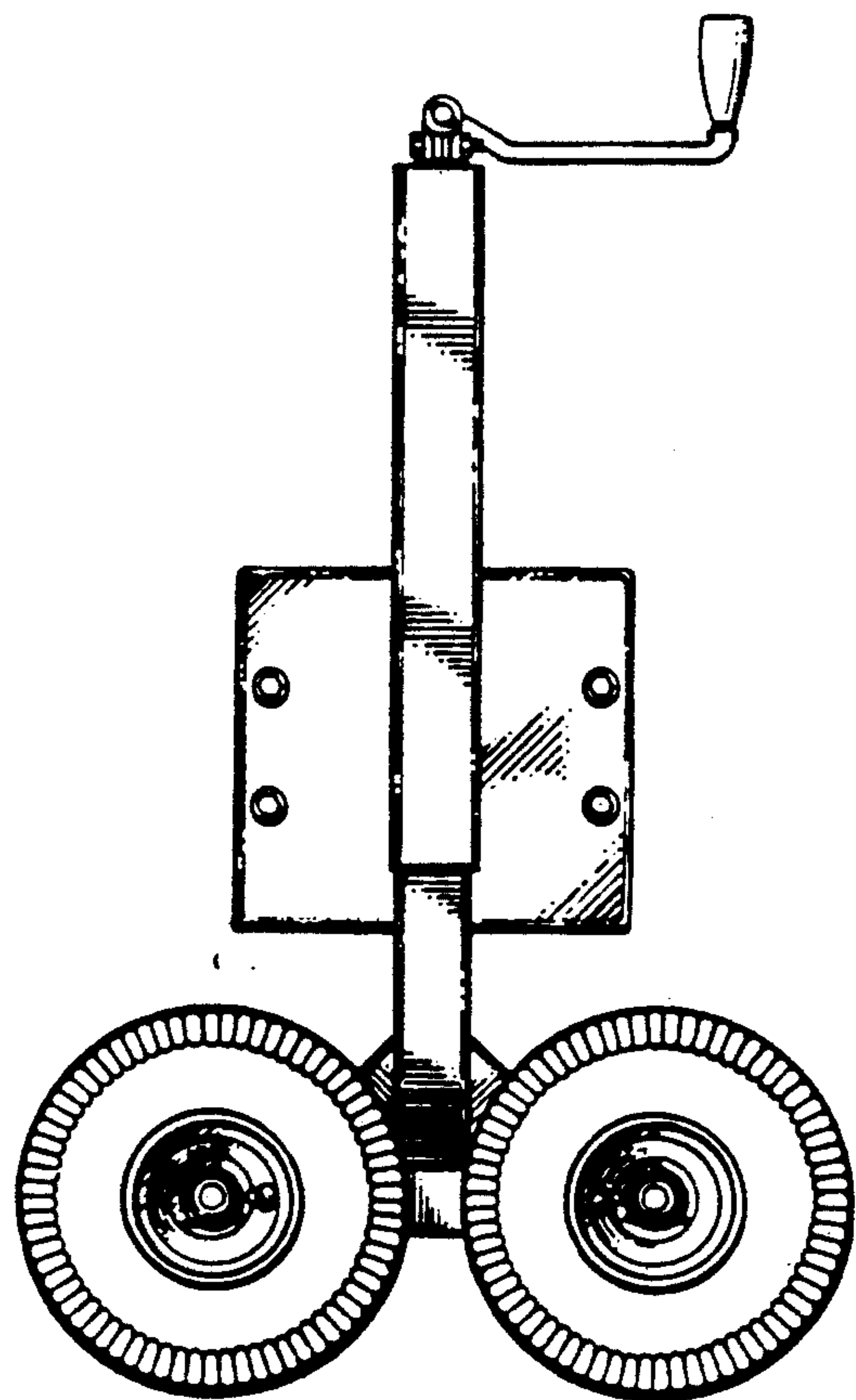

FIG. 5

