



US00D340021S

United States Patent [19]

[11] Patent Number: Des. 340,021

Yamamoto

[45] Date of Patent: ** Oct. 5, 1993

[54] VEHICULAR SKI CARRIER

[75] Inventor: Teruaki Yamamoto, Tokyo, Japan

[73] Assignee: Pias Design International Corporation, Tokyo, Japan

[**] Term: 14 Years

[21] Appl. No.: 748,911

[22] Filed: Aug. 23, 1991

[52] U.S. Cl. D12/157

[58] Field of Search D6/552; D12/157; 211/70.5, 70.6; 224/273, 309-310, 314-315, 323

[56] References Cited

U.S. PATENT DOCUMENTS

D. 282,060	1/1986	DiAntoni	D12/157
D. 300,914	5/1989	Arvidsson	D12/157
2,630,257	3/1953	Nielson	224/314
3,719,297	3/1973	Nowicki	224/315 X

Primary Examiner—Brian N. Vinson
Attorney, Agent, or Firm—Oblon, Spivak, McClelland, Maier & Neustadt

[57] CLAIM

The ornamental design for a vehicular ski carrier, as shown and described.

DESCRIPTION

FIG. 1 is a top, right and front perspective view of a vehicular ski carrier, showing my new design;
 FIG. 2 is a top plan view thereof;
 FIG. 3 is a right side view thereof;
 FIG. 4 is a left side view thereof;
 FIG. 5 is a front elevational view thereof;
 FIG. 6 is a bottom plan view thereof;
 FIG. 7 is a rear elevational view thereof;
 FIG. 8 is a top, right and front perspective view thereof in an open position; and,
 FIG. 9 is a top plan view with the upper arm shown in an upright position.

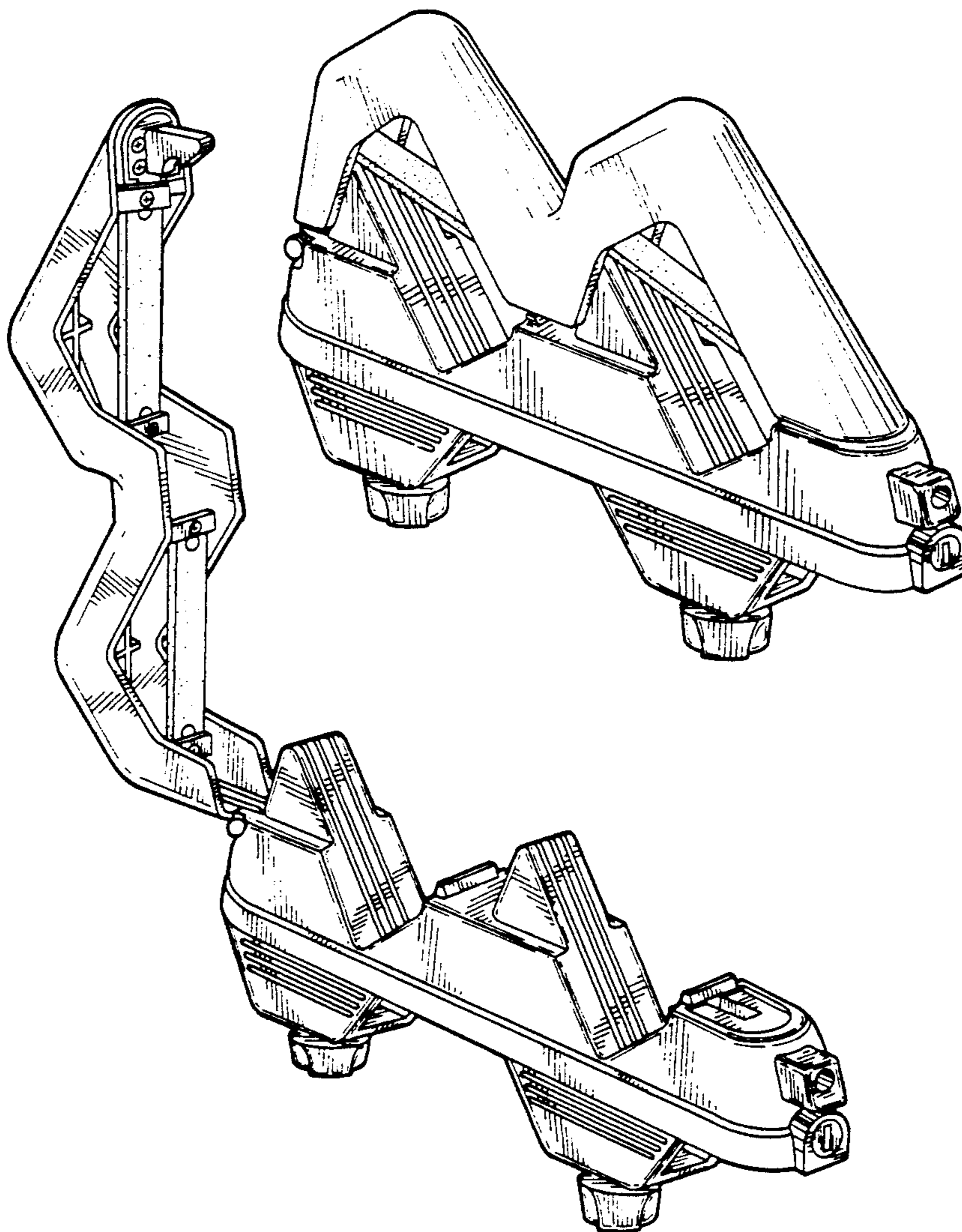

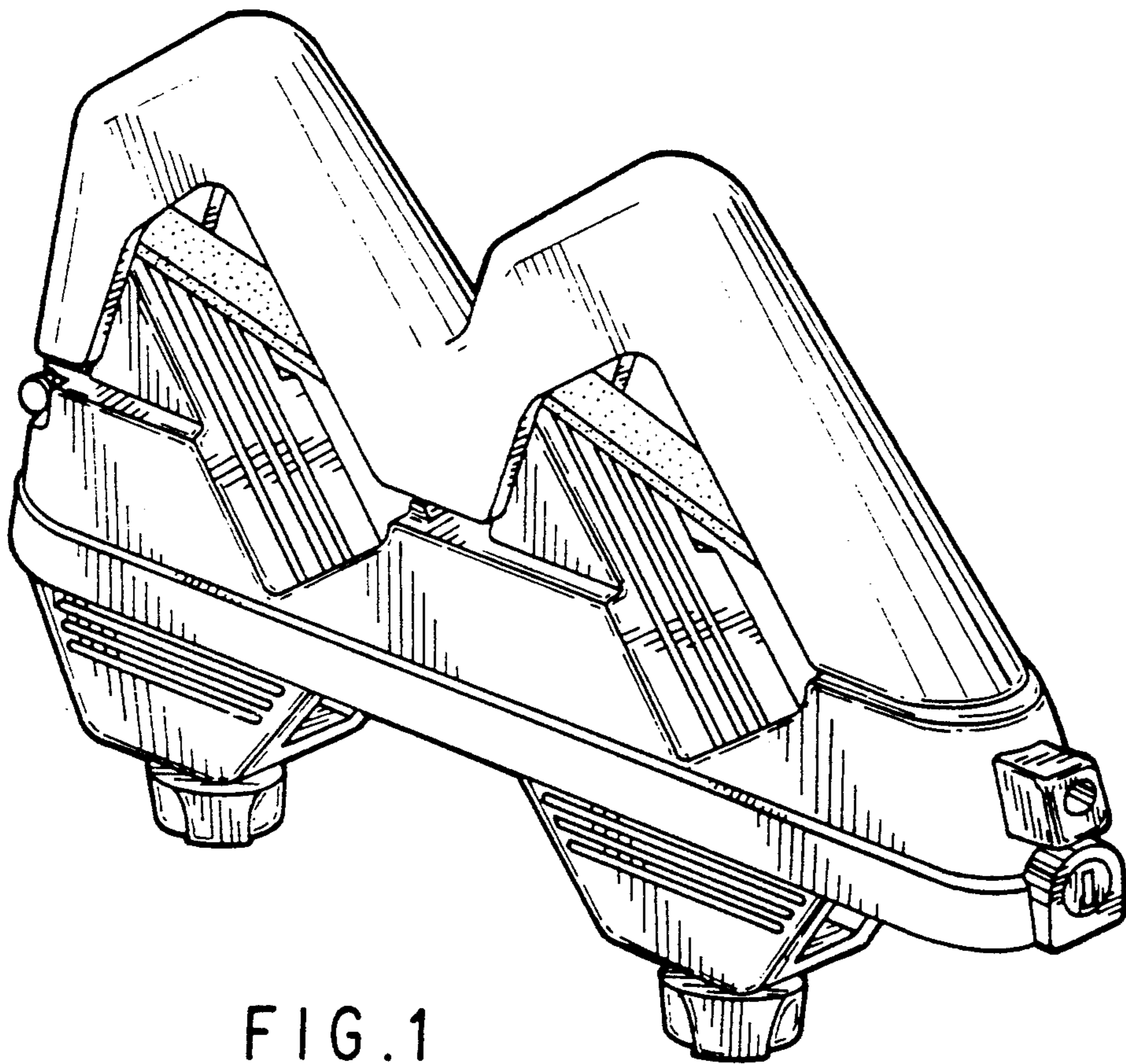

FIG. 1



FIG. 2

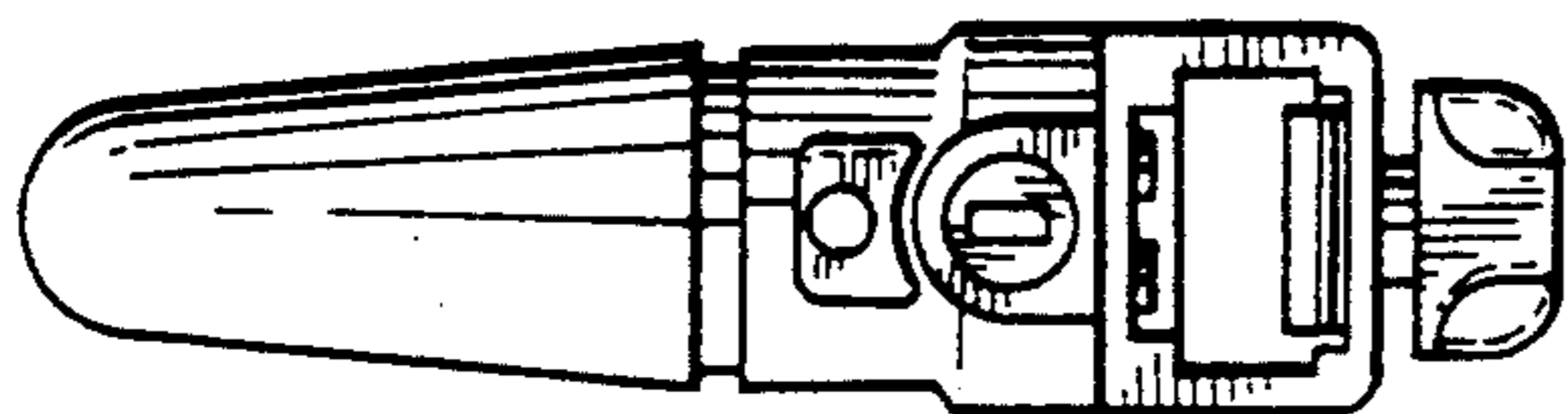

FIG. 3

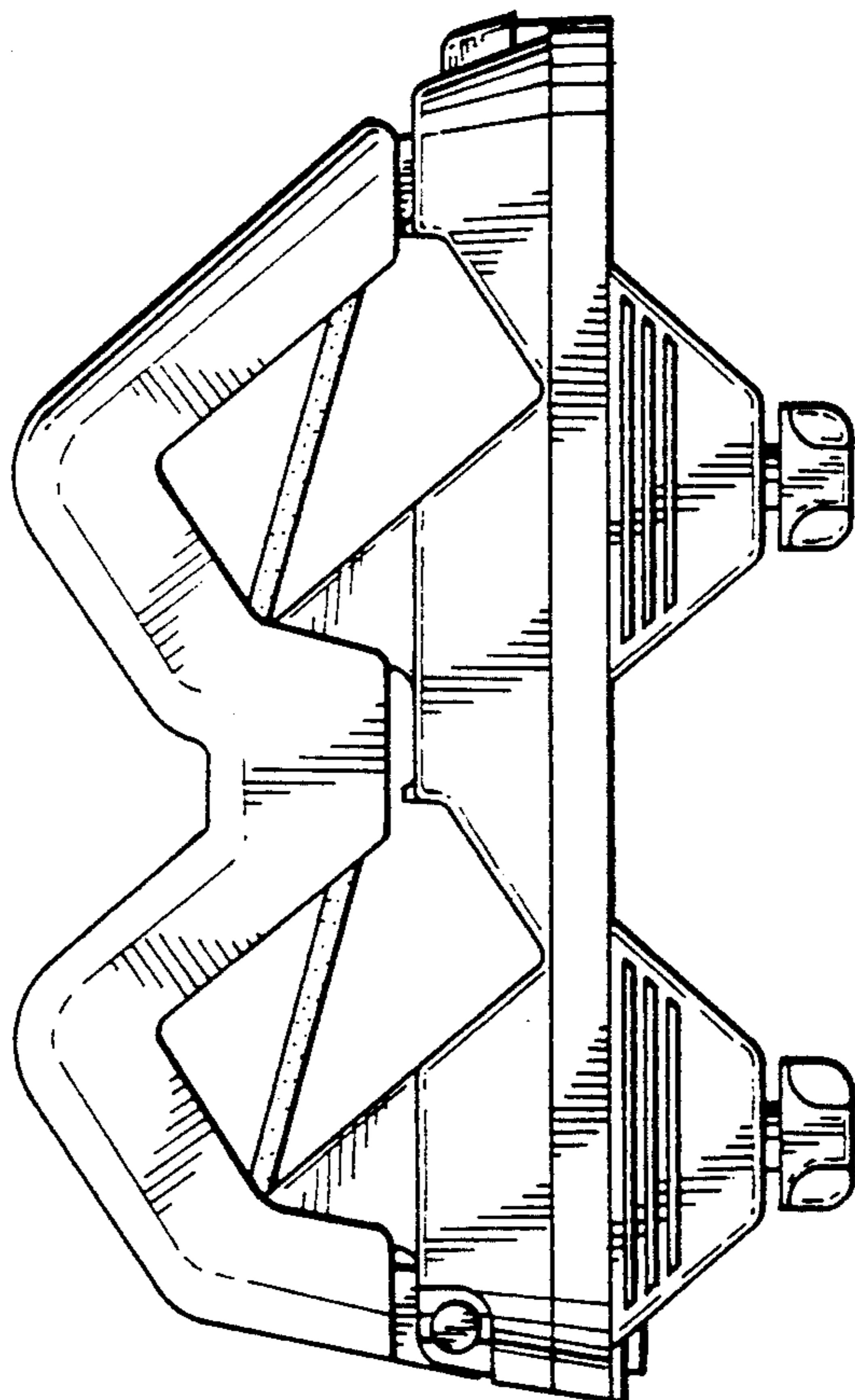

FIG. 5

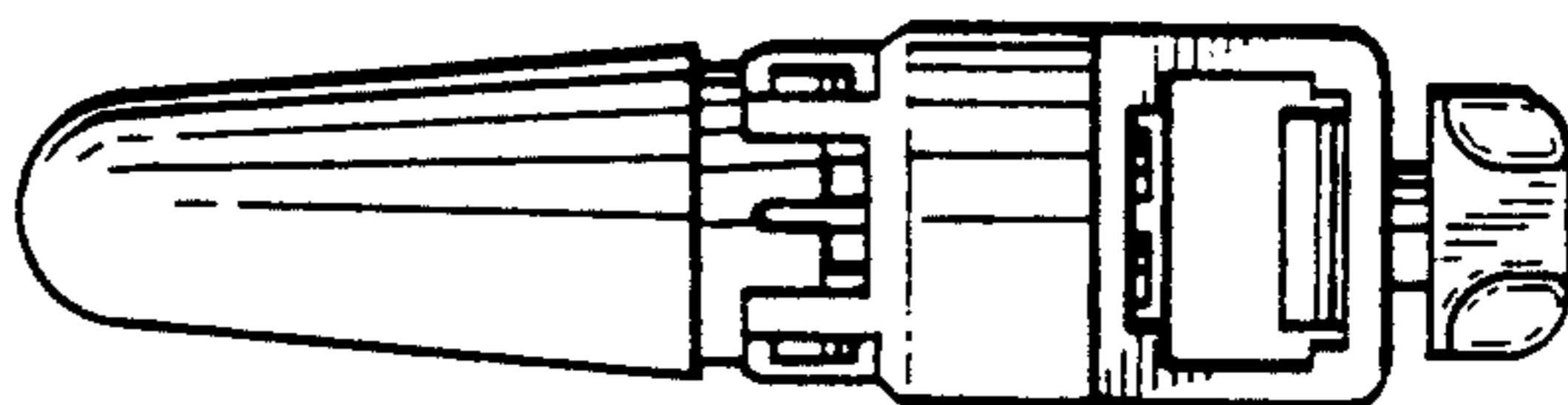

FIG. 4

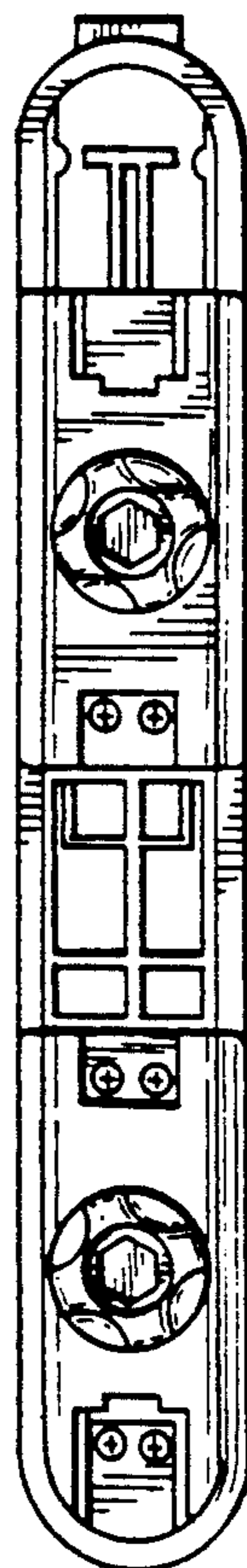

FIG. 6

FIG. 7

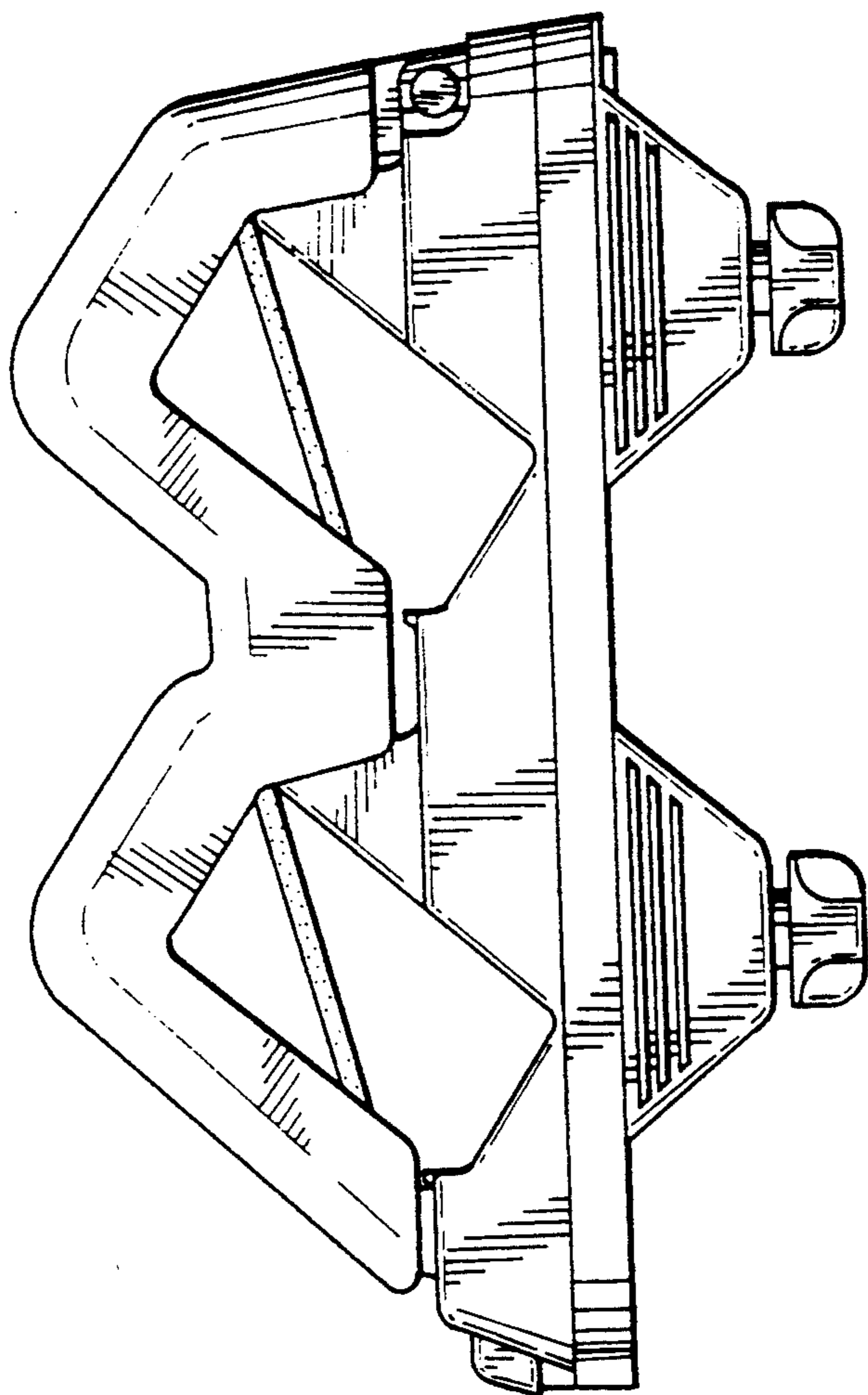
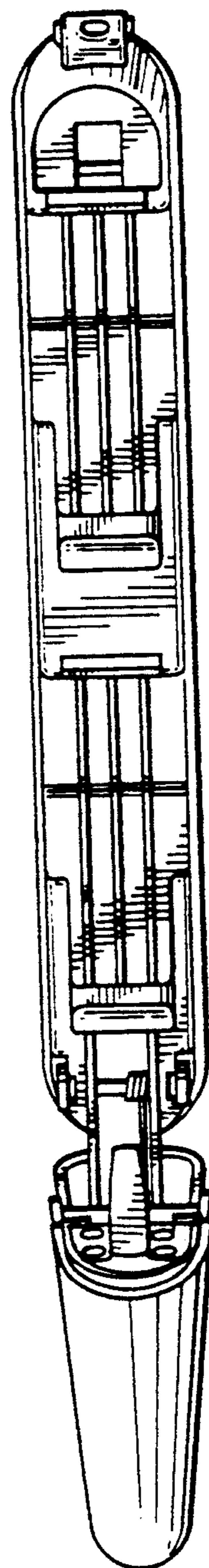

FIG. 9



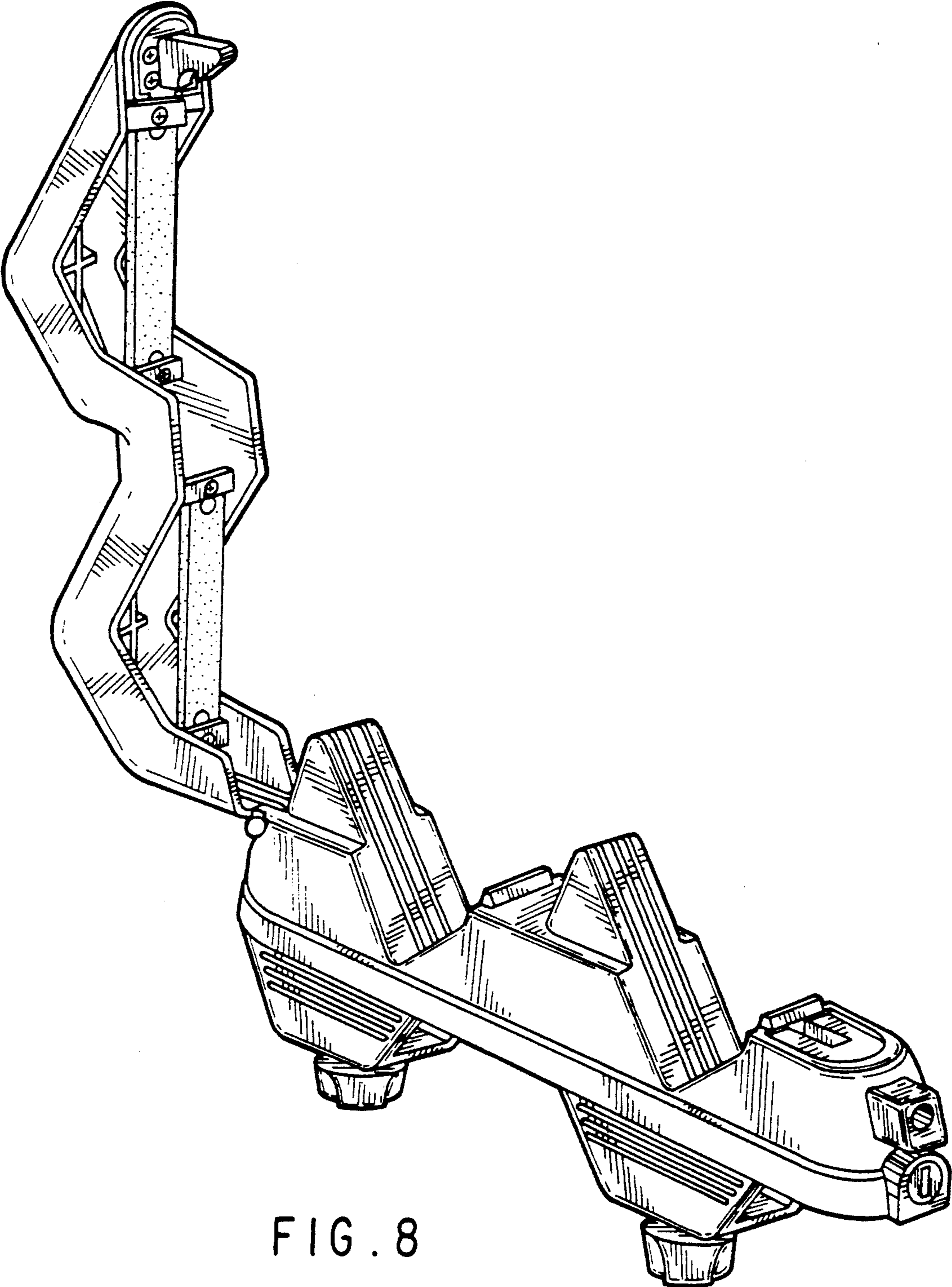

FIG. 8