



US00D340020S

# United States Patent [19]

Yamamoto

[11] Patent Number: **Des. 340,020**

[45] Date of Patent: **\*\* Oct. 5, 1993**

[54] **VEHICULAR SKI CARRIER**

[75] Inventor: **Teruaki Yamamoto, Tokyo, Japan**

[73] Assignee: **Piaa Design International Corporation, Tokyo, Japan**

[\*\*] Term: **14 Years**

[21] Appl. No.: **748,909**

[22] Filed: **Aug. 23, 1991**

[52] U.S. Cl. .... **D12/157**

[58] Field of Search ..... **D6/552; D12/157; 211/70.5, 70.6; 224/273, 309-310, 314-315, 323**

[56] **References Cited**

**U.S. PATENT DOCUMENTS**

D. 282,060	1/1986	DiAntoni .....	D12/157
D. 300,914	5/1989	Arvidsson .....	D12/157
2,630,257	3/1953	Nielson .....	224/314
3,719,297	3/1973	Nowicki .....	224/315 X

*Primary Examiner*—Brian N. Vinson  
*Attorney, Agent, or Firm*—Oblon, Spivak, McClelland, Maier & Neustadt

[57] **CLAIM**

The ornamental design for a vehicular ski carrier, as shown and described.

**DESCRIPTION**

FIG. 1 is a top, right and front perspective view of a vehicular ski carrier, showing my new design; FIG. 2 is a top plan view thereof; FIG. 3 is a right side view thereof; FIG. 4 is a left side view thereof; FIG. 5 is a front elevational view thereof; FIG. 6 is a bottom plan view thereof; FIG. 7 is a rear elevational view thereof; FIG. 8 is a top, right and front perspective view thereof in an open position; and, FIG. 9 is a top plan view thereof in an open position.

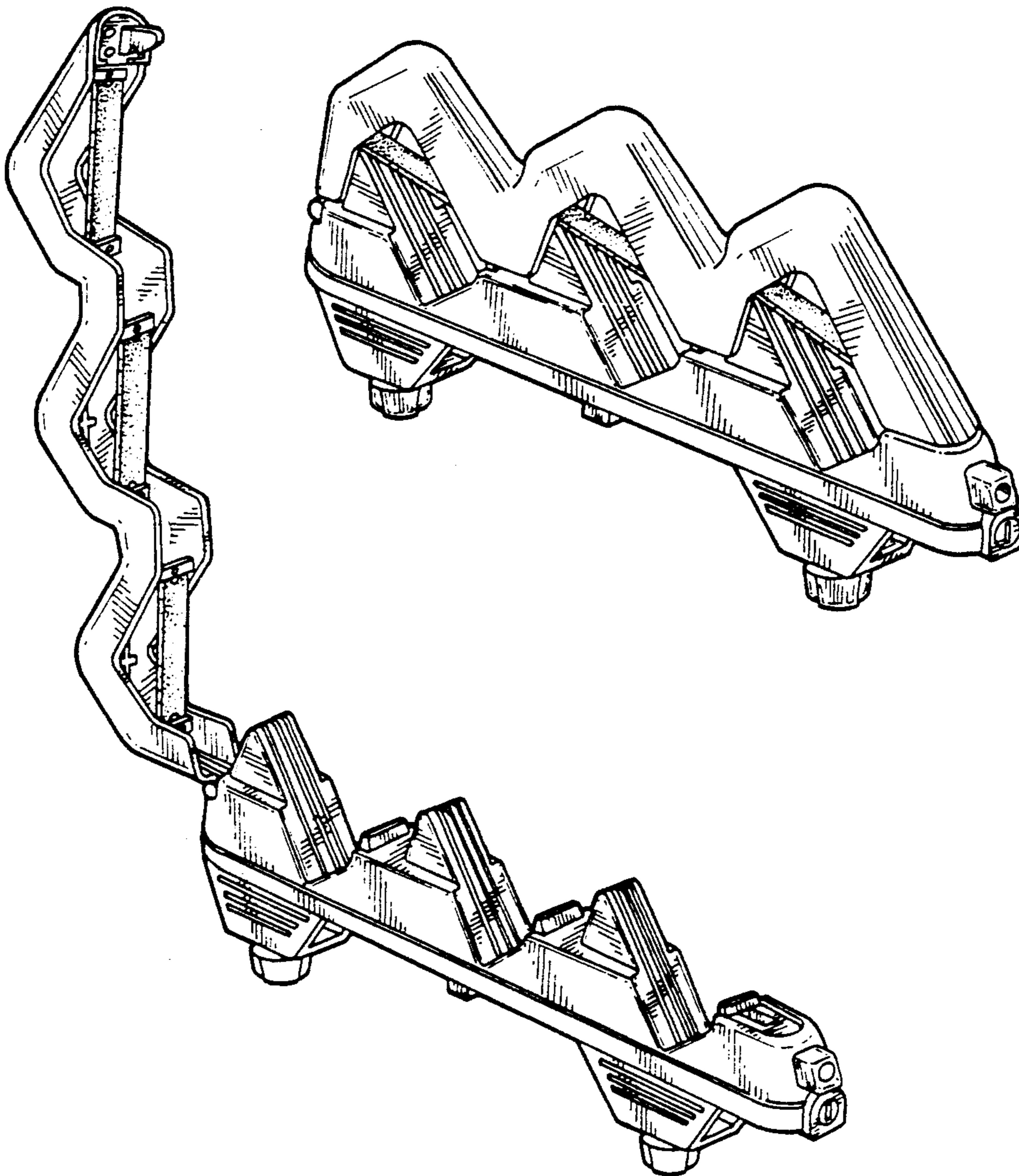
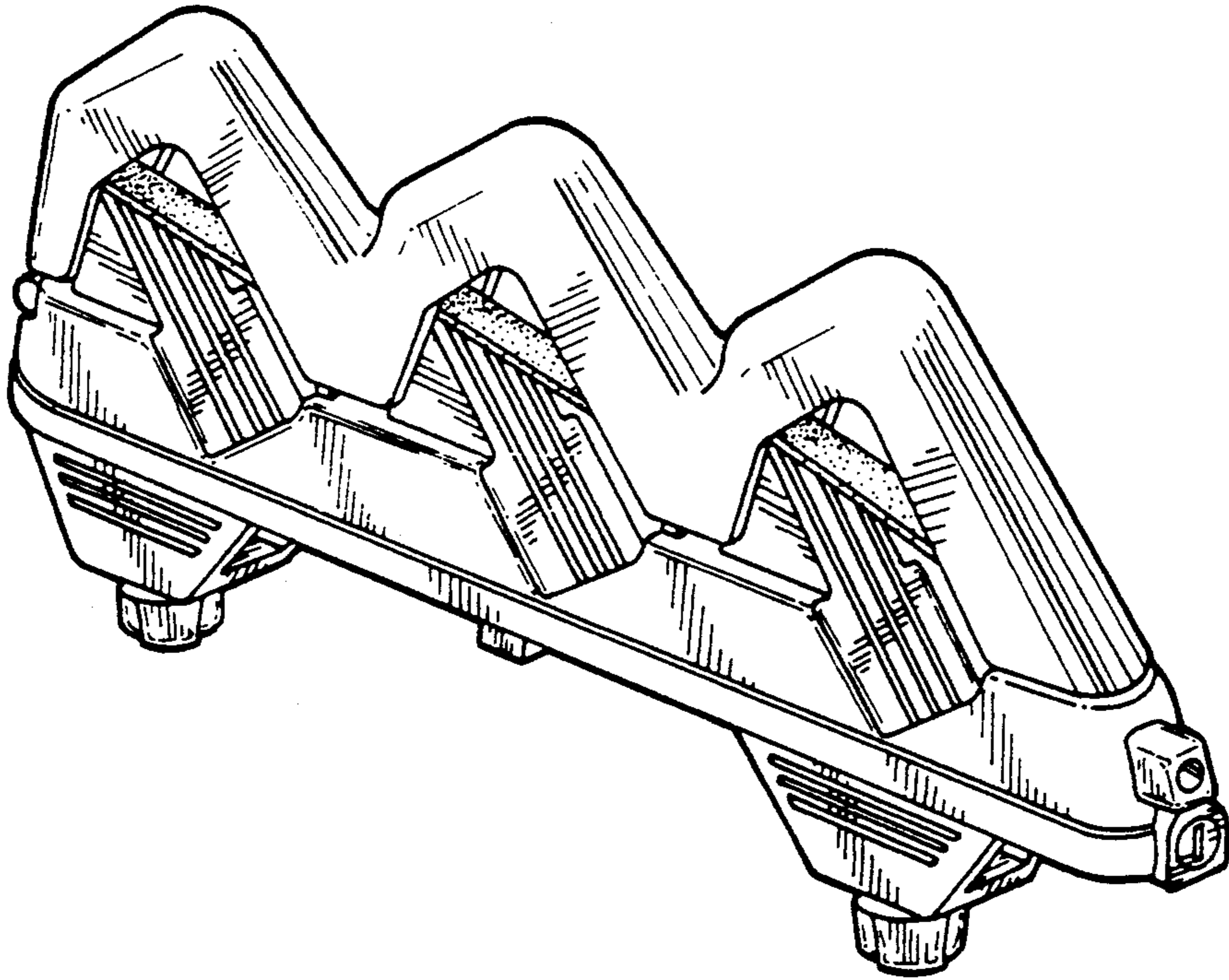

FIG. 1



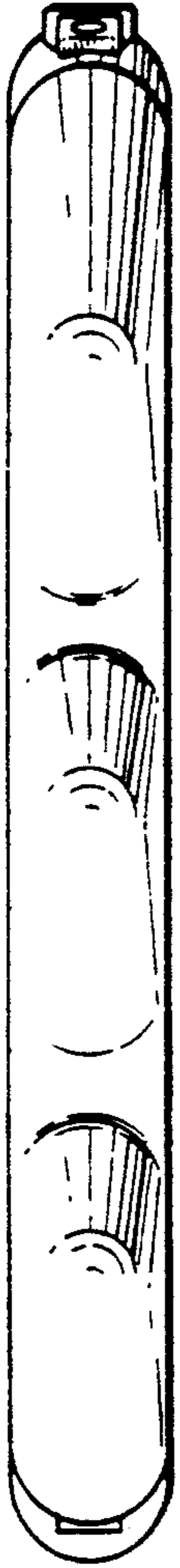

FIG. 2

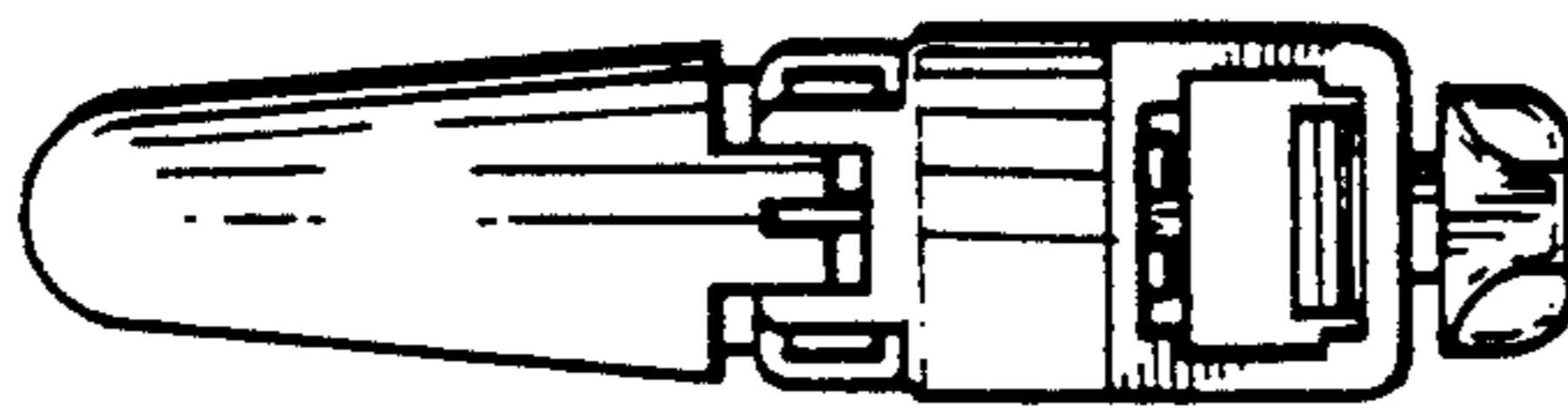

FIG. 4

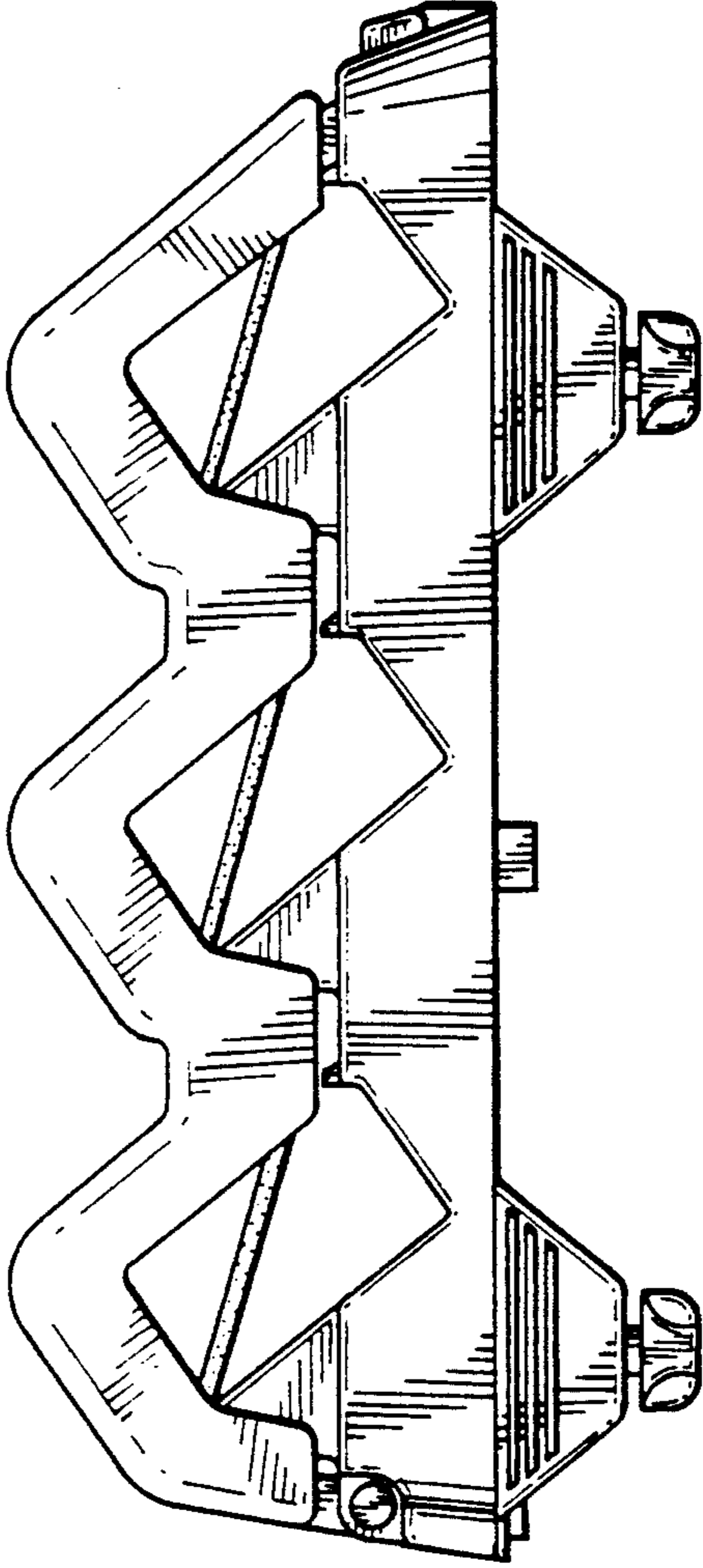

FIG. 5

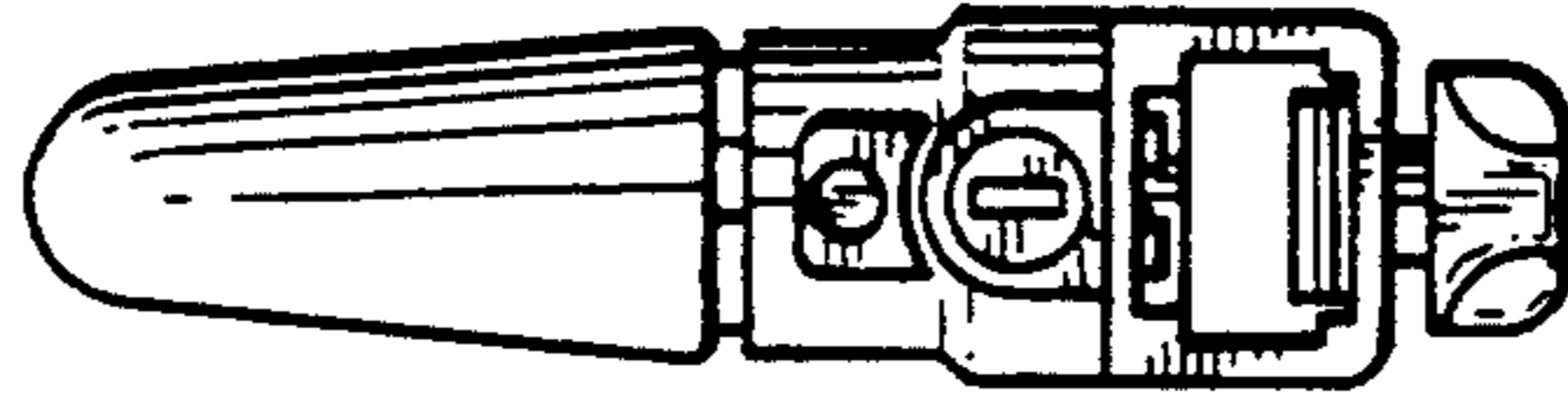

FIG. 3

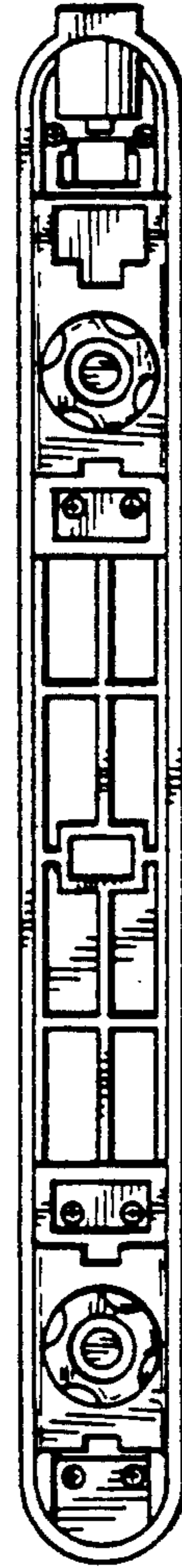

FIG. 6

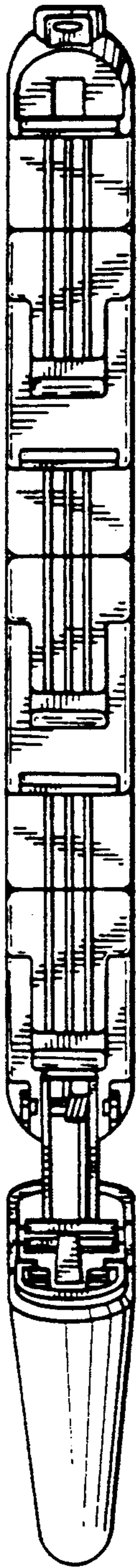

FIG. 9

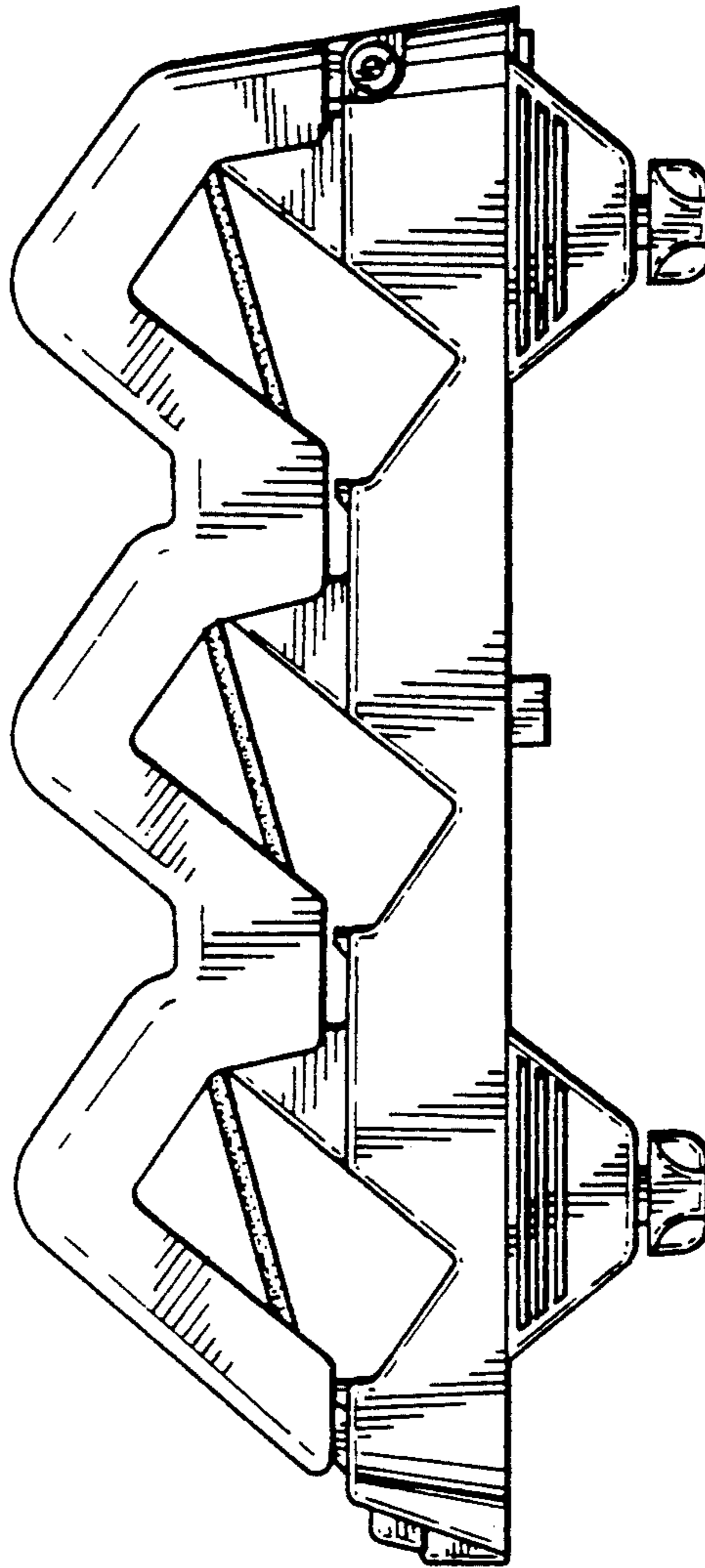

FIG. 7

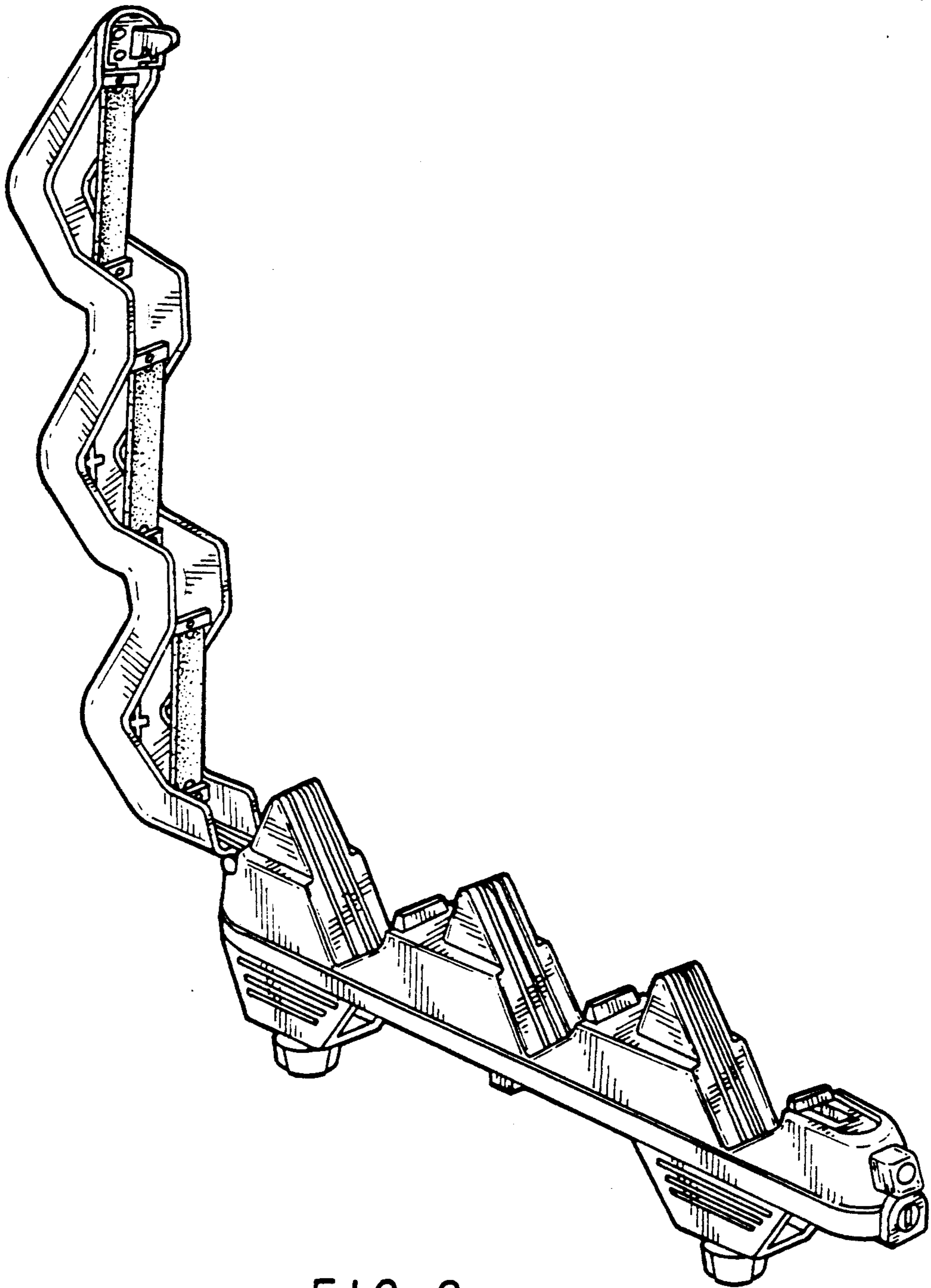

FIG. 8