



US00D339974S

United States Patent [19]

[11] Patent Number: **Des. 339,974**

Wilcox

[45] Date of Patent: **** Oct. 5, 1993**

[54] **HOLDER FOR A VEHICLE STEERING WHEEL LOCK BAR**

FOREIGN PATENT DOCUMENTS

[75] Inventor: **John R. Wilcox, Farrell, Pa.**

2106058 4/1983 United Kingdom D8/331 X

[73] Assignee: **Winner International, Sharon, Pa.**

Primary Examiner—Brian N. Vinson
Attorney, Agent, or Firm—Body, Vickers & Daniels

[**] Term: **14 Years**

[57] CLAIM

[21] Appl. No.: **796,231**

The ornamental design for a holder for a vehicle steering wheel lock bar, as shown and described.

[22] Filed: **Nov. 22, 1991**

DESCRIPTION

[52] U.S. Cl. **D8/343**

[58] Field of Search D8/330, 331, 343-344;
70/209-212, 233, 237-238, 225-226, 14, 15,
17-19, 57-58, 30, 49; 292/256, 758;
248/316.1-316.5; 274/311, 315, 323,
42.38-42.40, 42.45

FIG. 1 is a bottom, front, and right side perspective view of a holder for a vehicle steering wheel lock bar showing my new design, the broken-line disclosure of a steering wheel lock bar being for illustrative purposes only and forming no part of the claimed design;

FIG. 2 is an enlarged top plan view thereof;

FIG. 3 is an enlarged front elevational view thereof;

FIG. 4 is an enlarged bottom plan view thereof;

FIG. 5 is an enlarged left side elevational view thereof;

FIG. 6 is an enlarged right side elevational view thereof; and,

FIG. 7 is an enlarged rear elevational view thereof.

[56] References Cited

U.S. PATENT DOCUMENTS

2,556,900 6/1951 Buschhorn 70/19 X
5,127,562 7/1992 Zane et al. 70/233 X

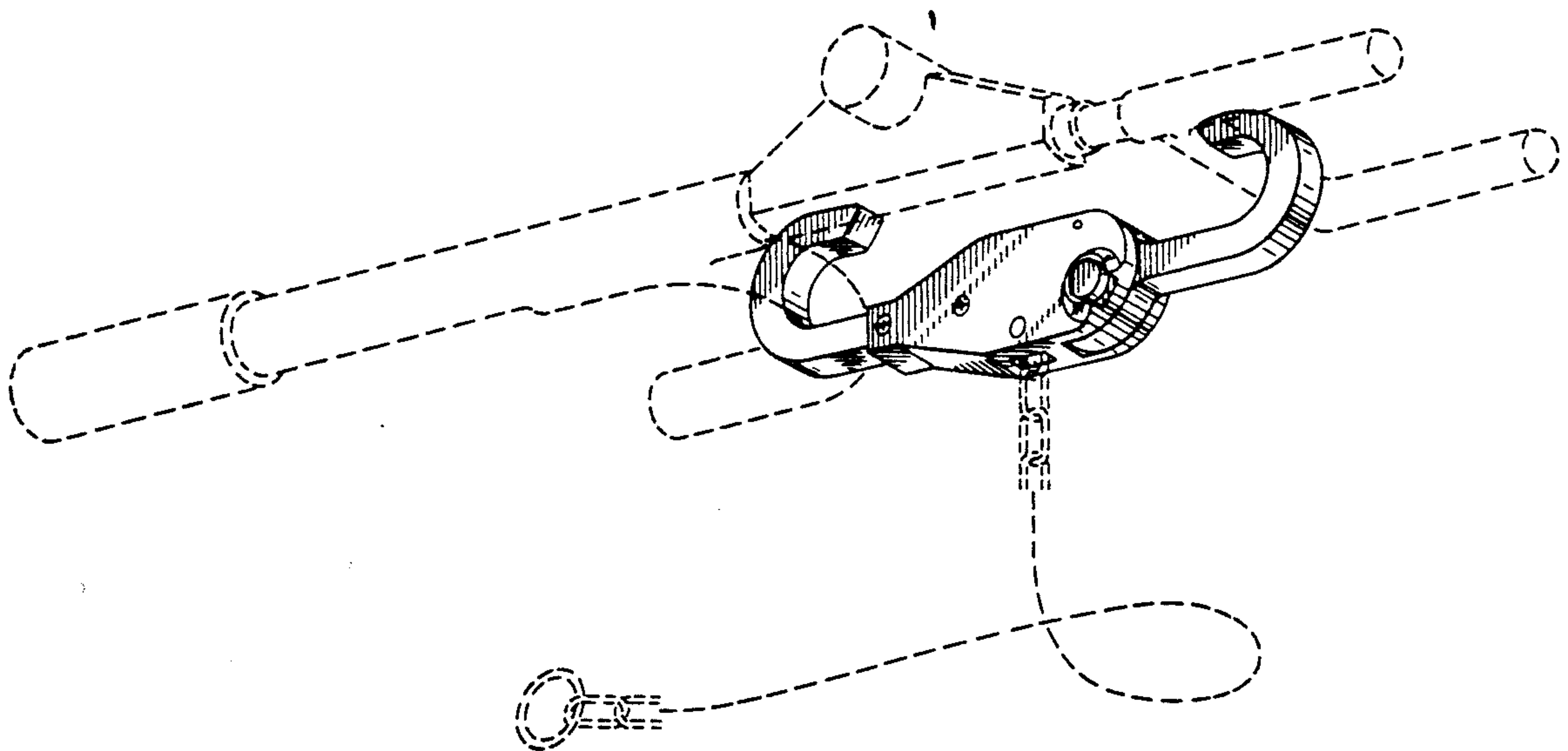

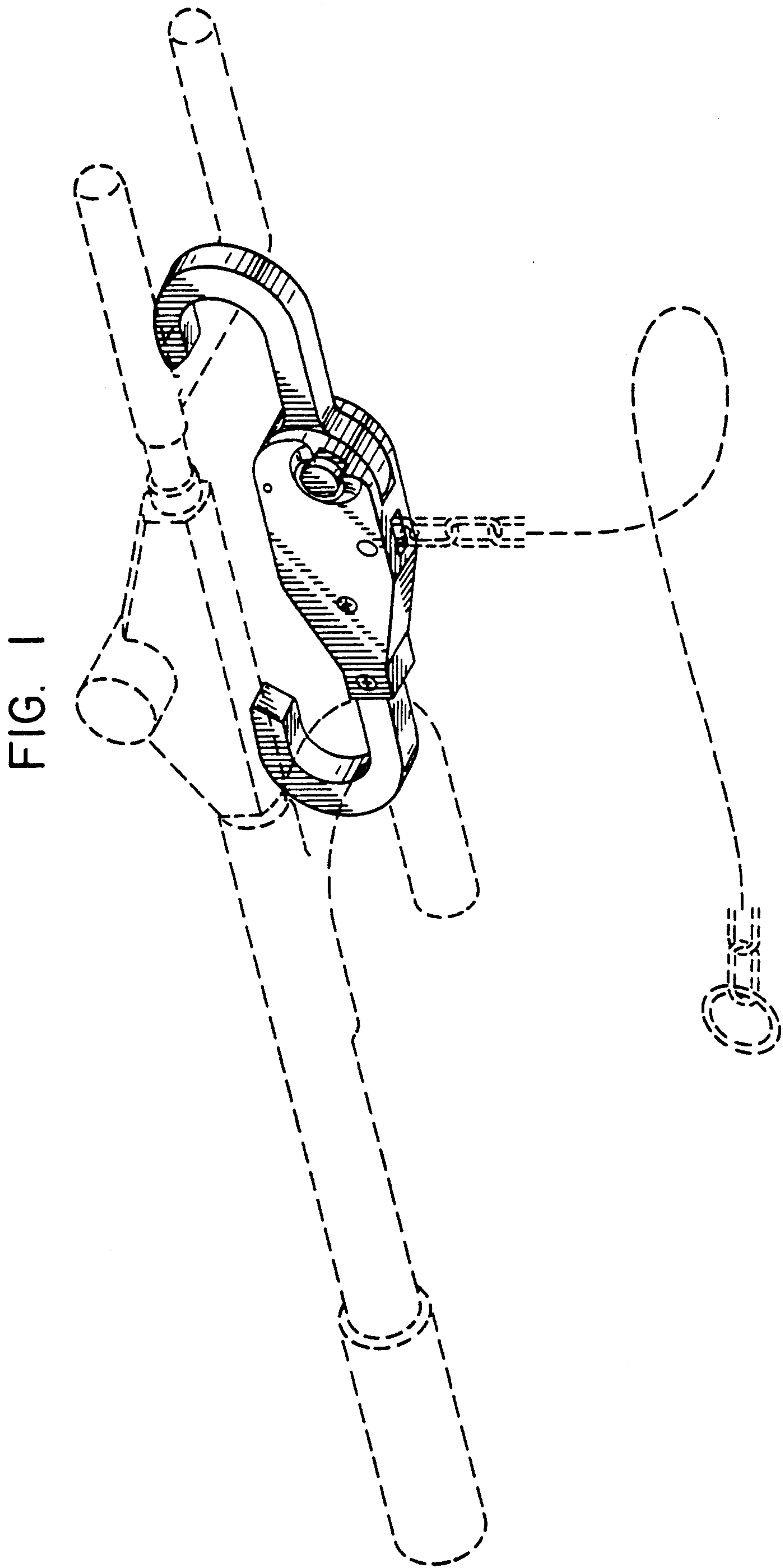

FIG. 2

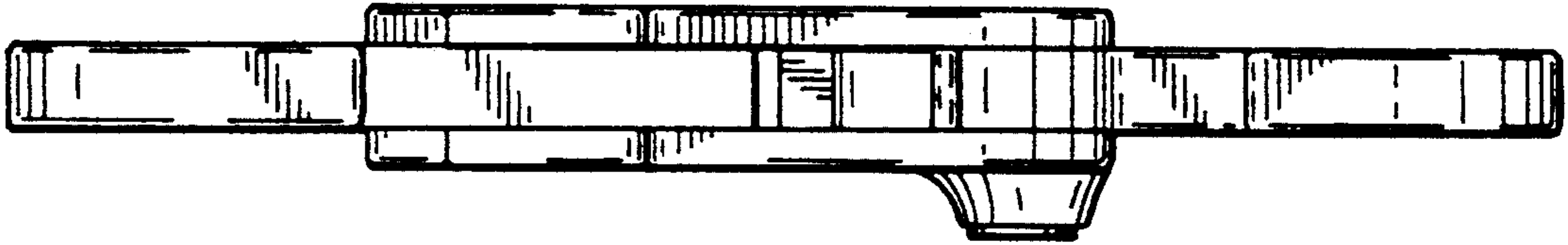

FIG. 3

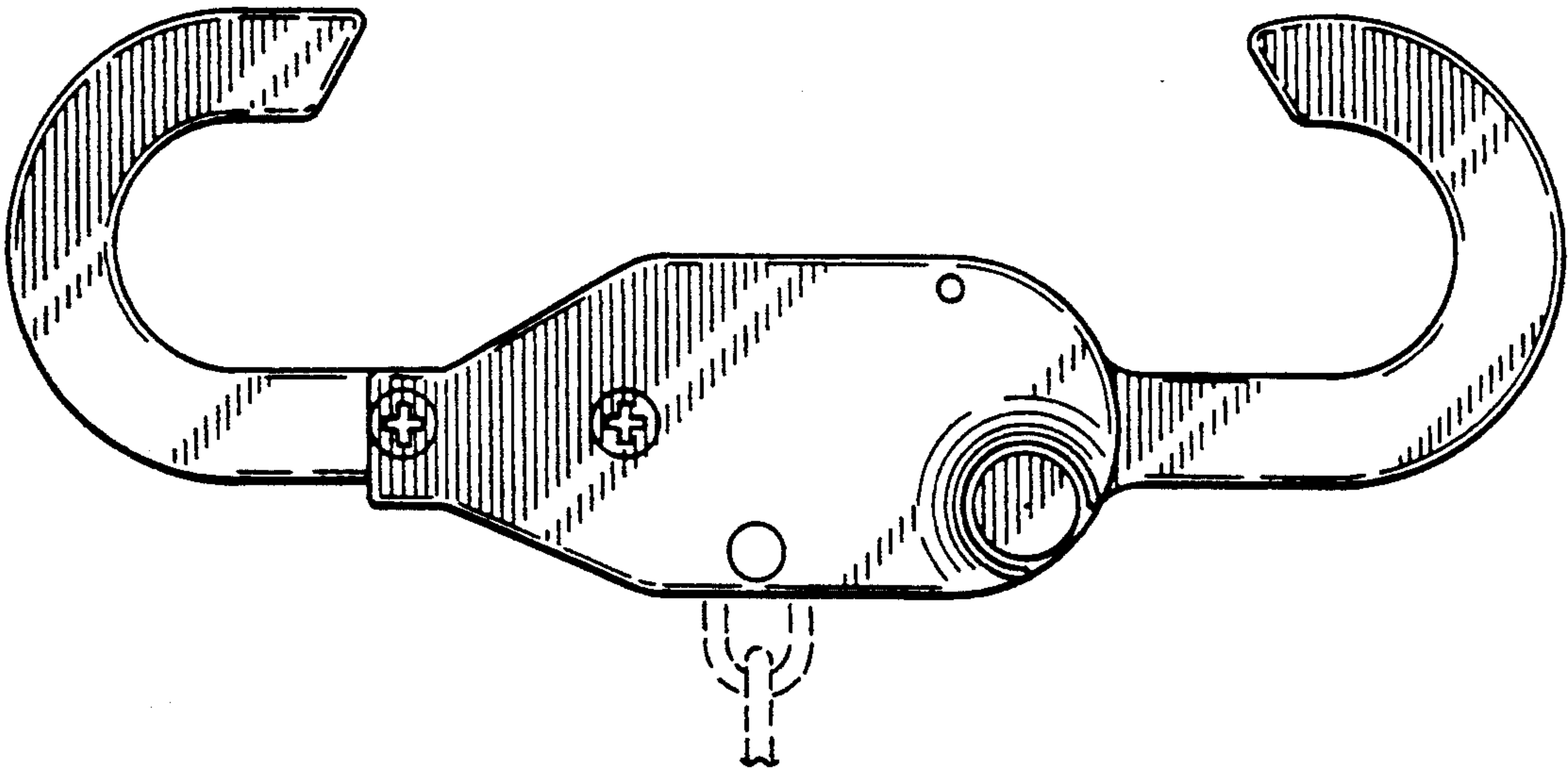

FIG. 4

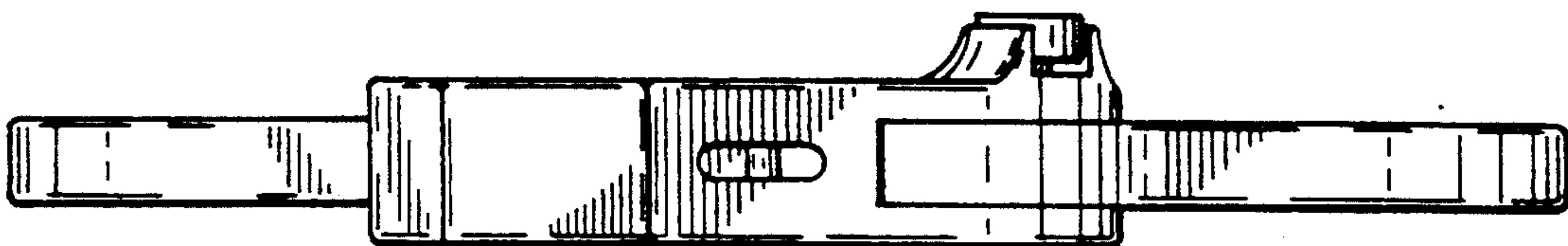

FIG. 5

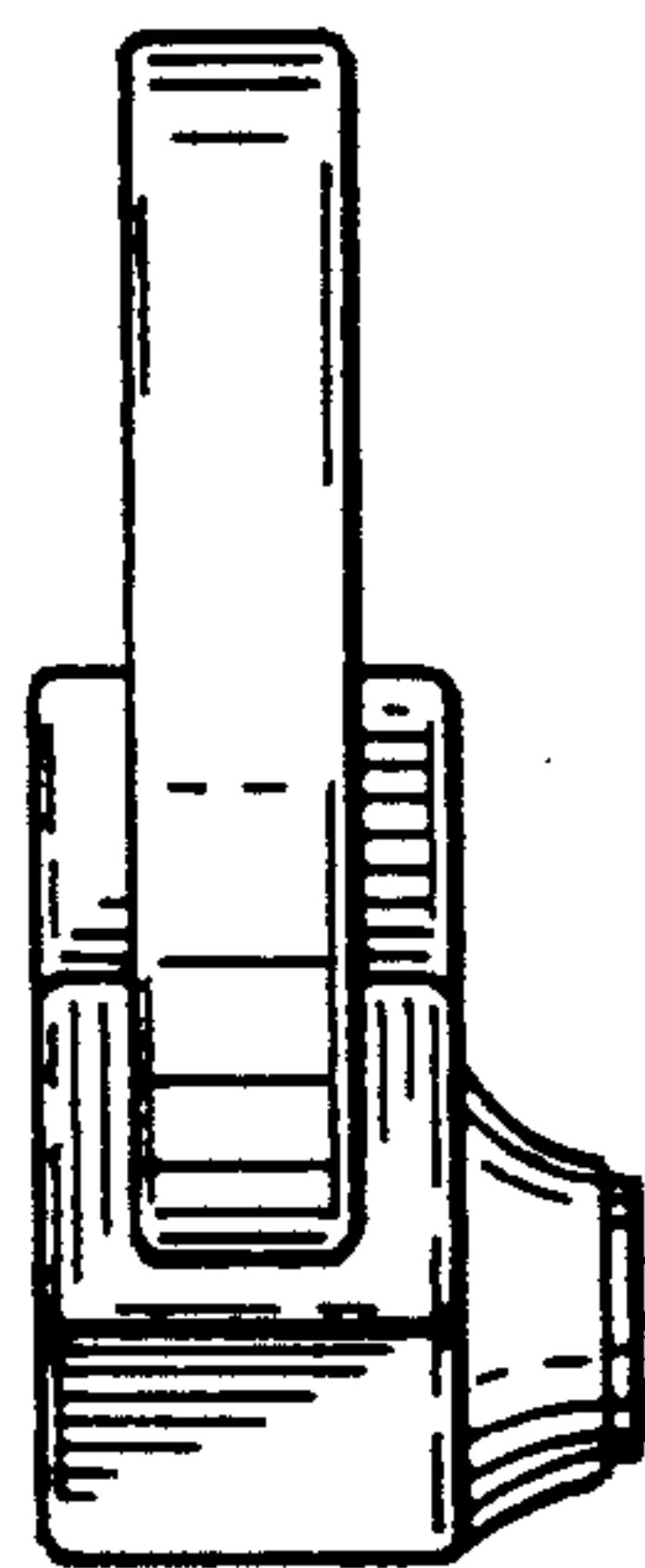

FIG. 6

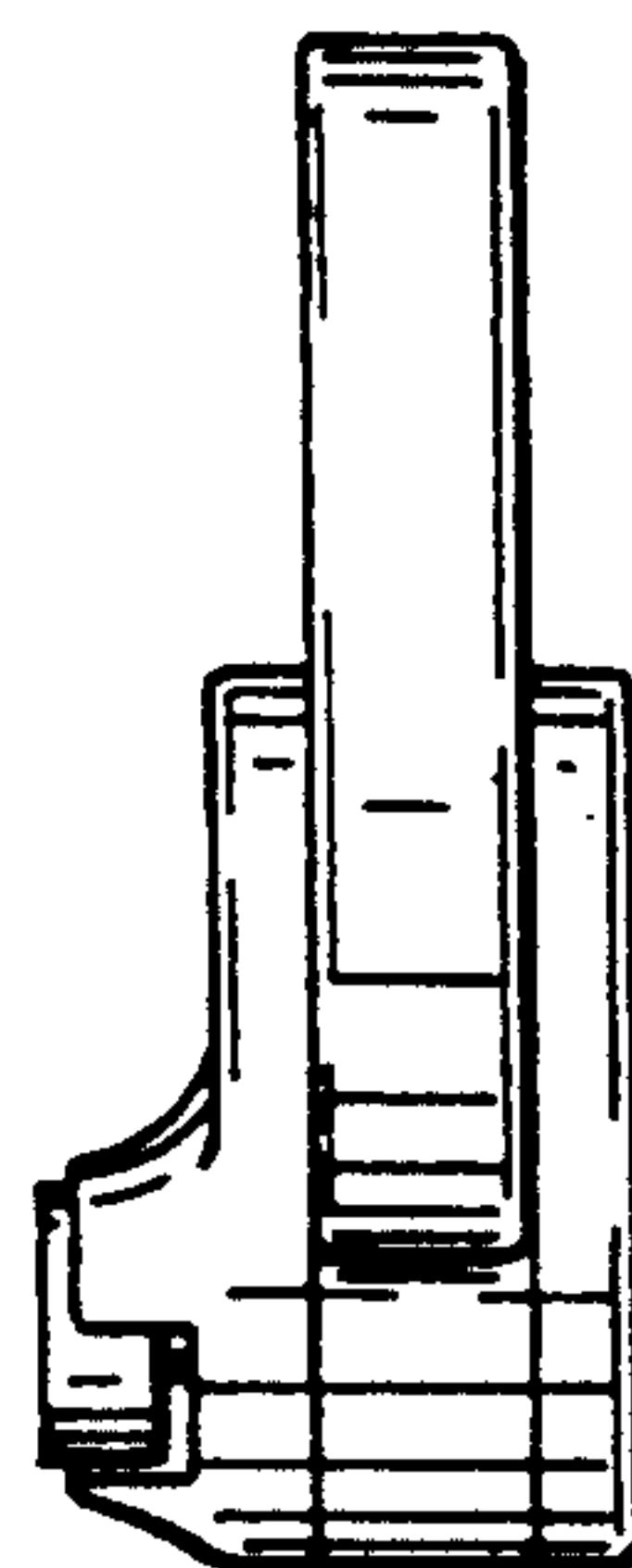

FIG. 7

