



US00D339776S

United States Patent [19]

Hayakawa et al.

[11] Patent Number: **Des. 339,776**

[45] Date of Patent: **** Sep. 28, 1993**

[54] AUTOMOBILE TIRE

[75] Inventors: **Toshio Hayakawa; Yasuo Himuro; Masato Hiruma**, all of Tokyo, Japan

[73] Assignee: **Bridgestone Corporation**, Tokyo, Japan

[**] Term: **14 Years**

[21] Appl. No.: **688,204**

[22] Filed: **Apr. 18, 1991**

[30] Foreign Application Priority Data

Oct. 18, 1990 [JP] Japan 2-34603

[52] U.S. Cl. **D12/147**

[58] Field of Search **D12/137, 140, 141-151; 152/209 R, 209 B, 209 D**

[56] References Cited

U.S. PATENT DOCUMENTS

- D. 266,919 11/1982 Bennett D12/146
- D. 307,121 4/1990 Messer D12/147
- D. 313,210 12/1990 Tsutsumi et al. D12/146

FOREIGN PATENT DOCUMENTS

0275202 11/1989 Japan 152/209 D

OTHER PUBLICATIONS

1989 Tread Design Guide, p. 62, Riken ZTX-35/40/45 tire, second tire in from the right side of page.

Primary Examiner—James M. Gandy
Attorney, Agent, or Firm—Sughrue, Mion, Zinn, Macpeak & Seas

[57] CLAIM

The ornamental design for an automobile tire, as shown and described.

DESCRIPTION

FIG. 1 is a perspective view of an automobile tire showing our new design, it being understood that the tread pattern is repeated uniformly throughout the circumference of the tire;

FIG. 2 is a front elevation view thereof;

FIG. 3 is a side elevation view thereof, the opposite side being substantially a mirror image of that shown;

FIG. 4 is an enlarged fragmentary front elevation view thereof; and,

FIG. 5 is a cross-sectional view taken along line 5—5 in FIG. 4.

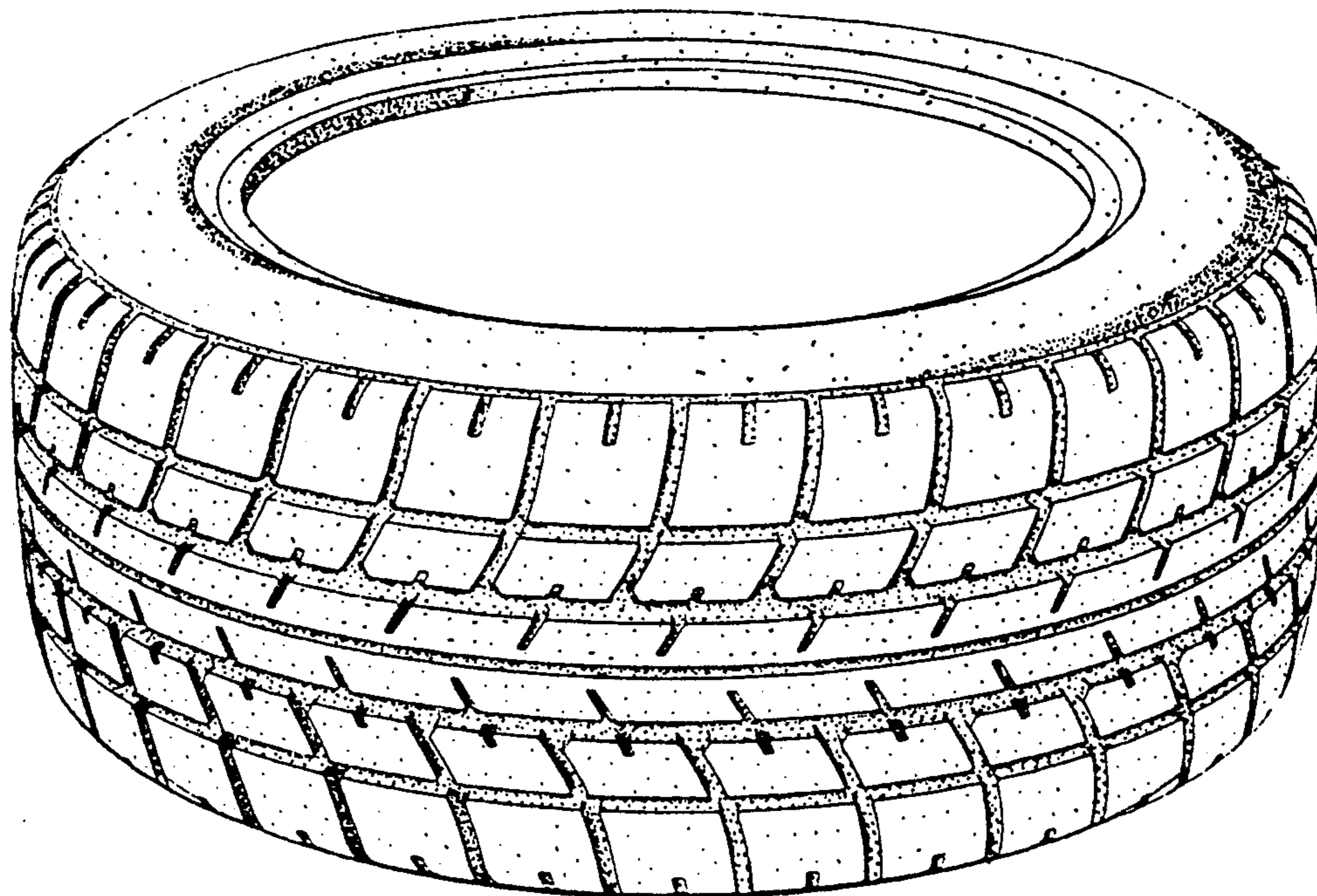

FIG. 1

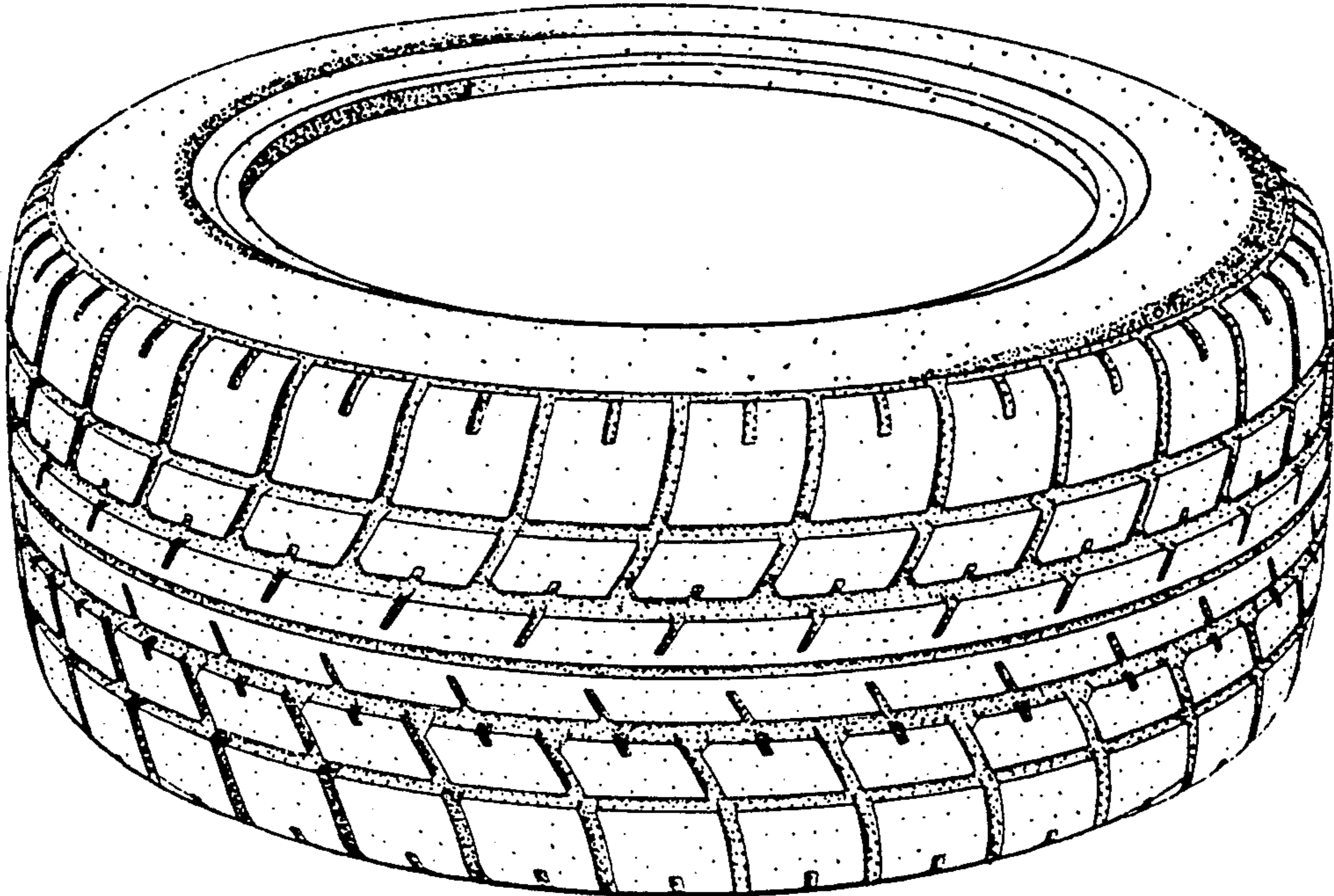

FIG. 2

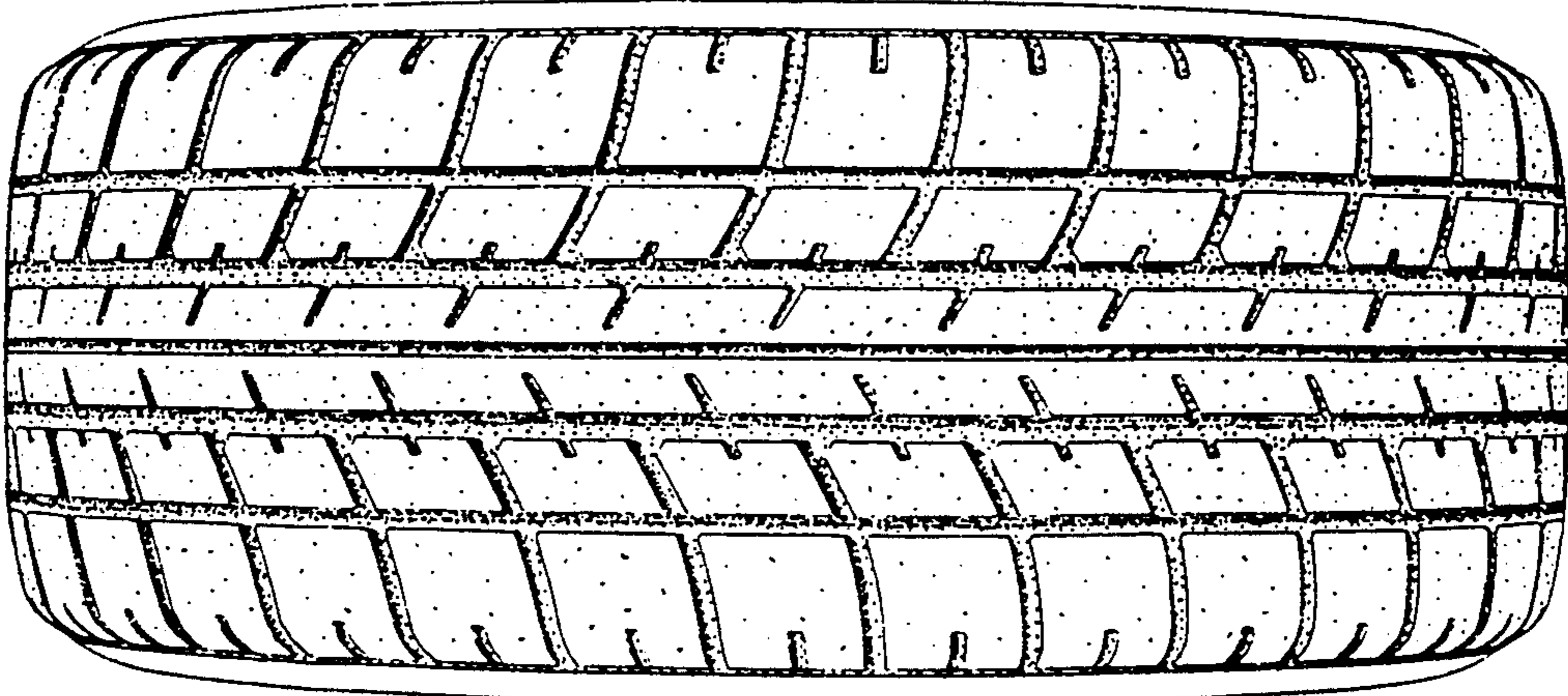

FIG. 3

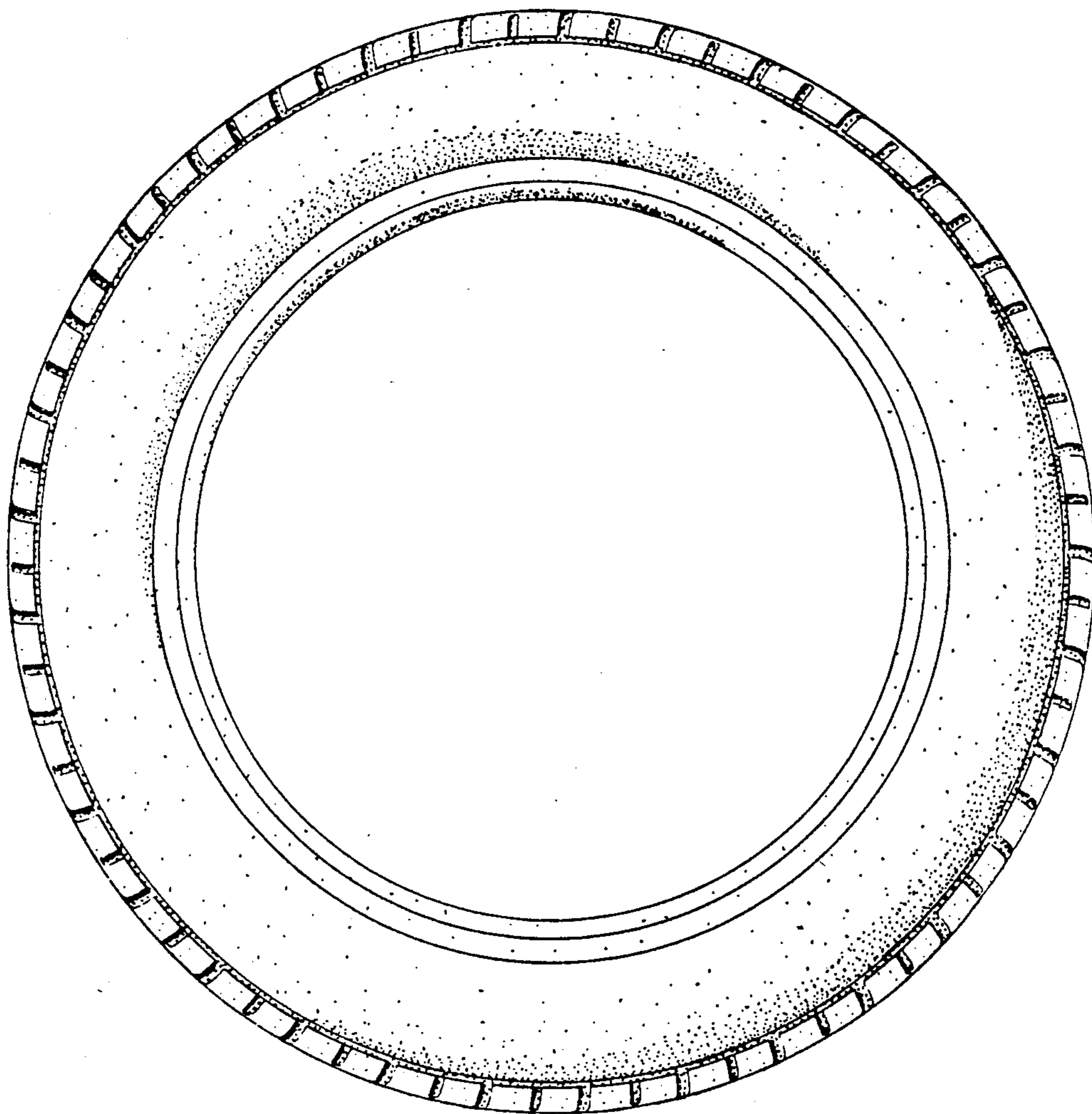

FIG. 4

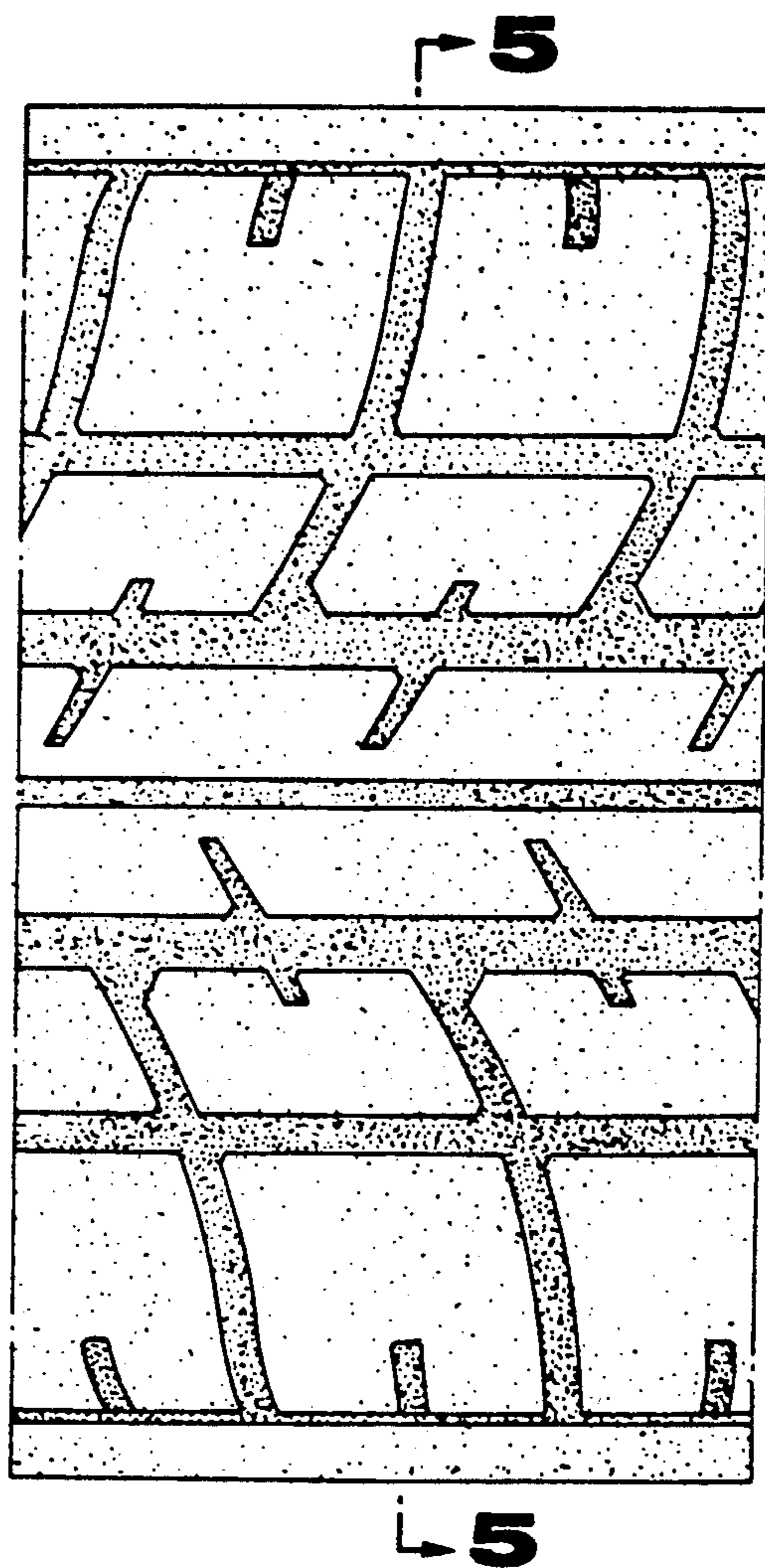

FIG. 5

