



US00D338826S

United States Patent [19]

Schmidt et al.

[11] Patent Number: Des. 338,826

[45] Date of Patent: ** Aug. 31, 1993

[54] MOUNTING BRACKET

[76] Inventors: William P. Schmidt, 21000 Woodruff, Rockwood, Mich. 48173; Frank D. Hutchinson, 28000 Beel Rd., New Boston, Mich. 48164

[**] Term: 14 Years

[21] Appl. No.: 667,093

[22] Filed: Mar. 11, 1991

[52] U.S. Cl. D8/373

[58] Field of Search D8/373, 349, 354, 380, D8/400, 363; 248/476

D. 327,001	6/1992	Oosterhuis	D8/373
3,433,448	3/1969	Weber	248/476
3,989,359	11/1976	Shutt	359/872

Primary Examiner—Wallace R. Burke
Assistant Examiner—H. Baynham
Attorney, Agent, or Firm—Weintraub, DuRoss & Brady

[57] CLAIM

The ornamental design for a vehicular mirror mounting bracket, as shown.

DESCRIPTION

FIG. 1 is the perspective view of a vehicular mirror mounting bracket showing our new design; FIG. 2 is the rear elevational view thereof; FIG. 3 is the top plan view thereof; FIG. 4 is the left side elevational view thereof showing the article in use; and, FIG. 5 is a bottom plan view thereof. The broken line showing a rounded surface and attachments is for illustrative purpose only and forms no part of the claimed design.

[56] References Cited

U.S. PATENT DOCUMENTS

D. 227,858	7/1973	Goldman	D8/373
D. 243,581	3/1977	Goss, Jr. et al.	D8/400 X
D. 248,910	8/1978	De Filippo	D8/373 X
D. 275,178	8/1984	Yeater	D8/380
D. 288,282	2/1987	Sheets	D8/373

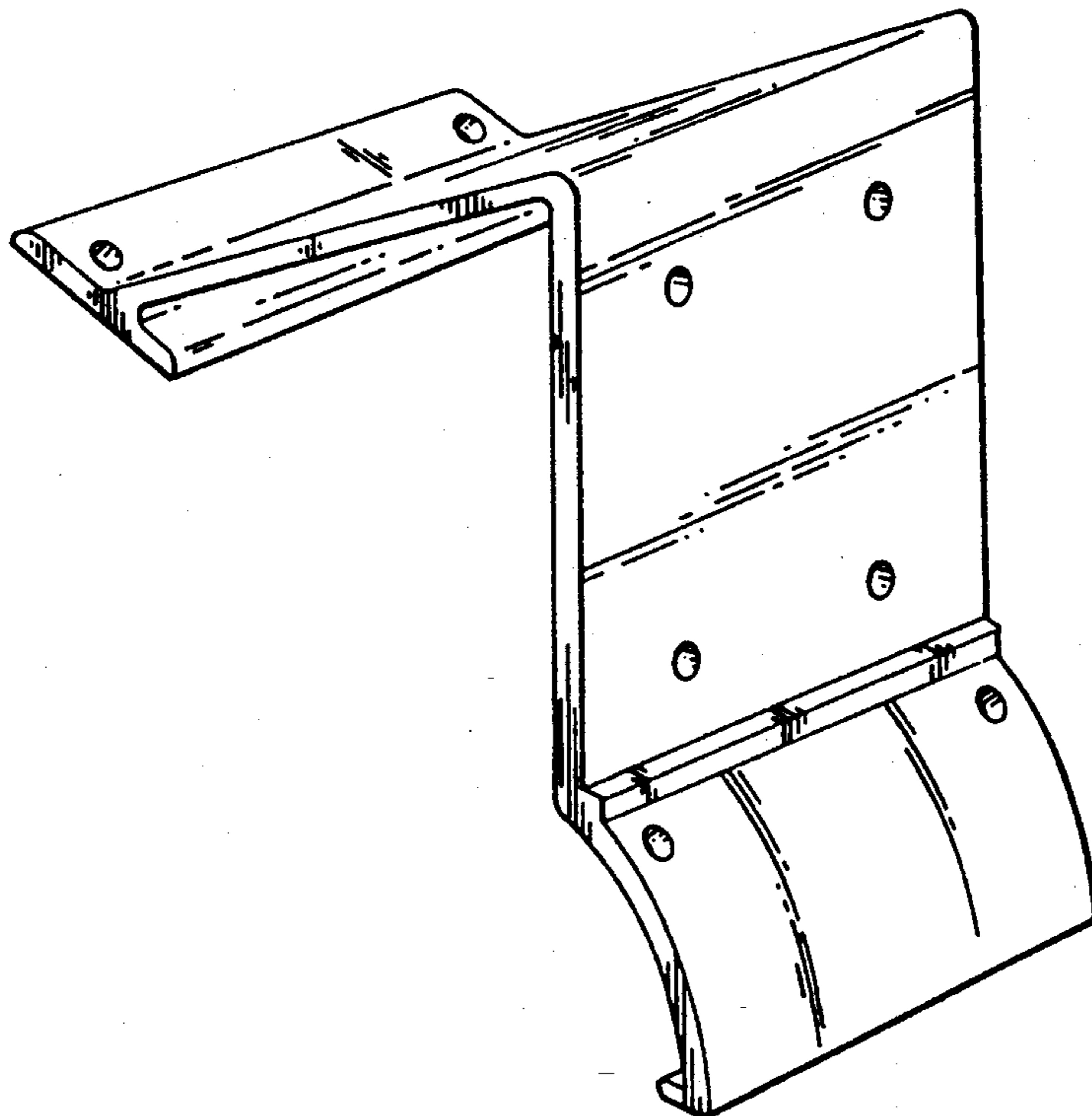

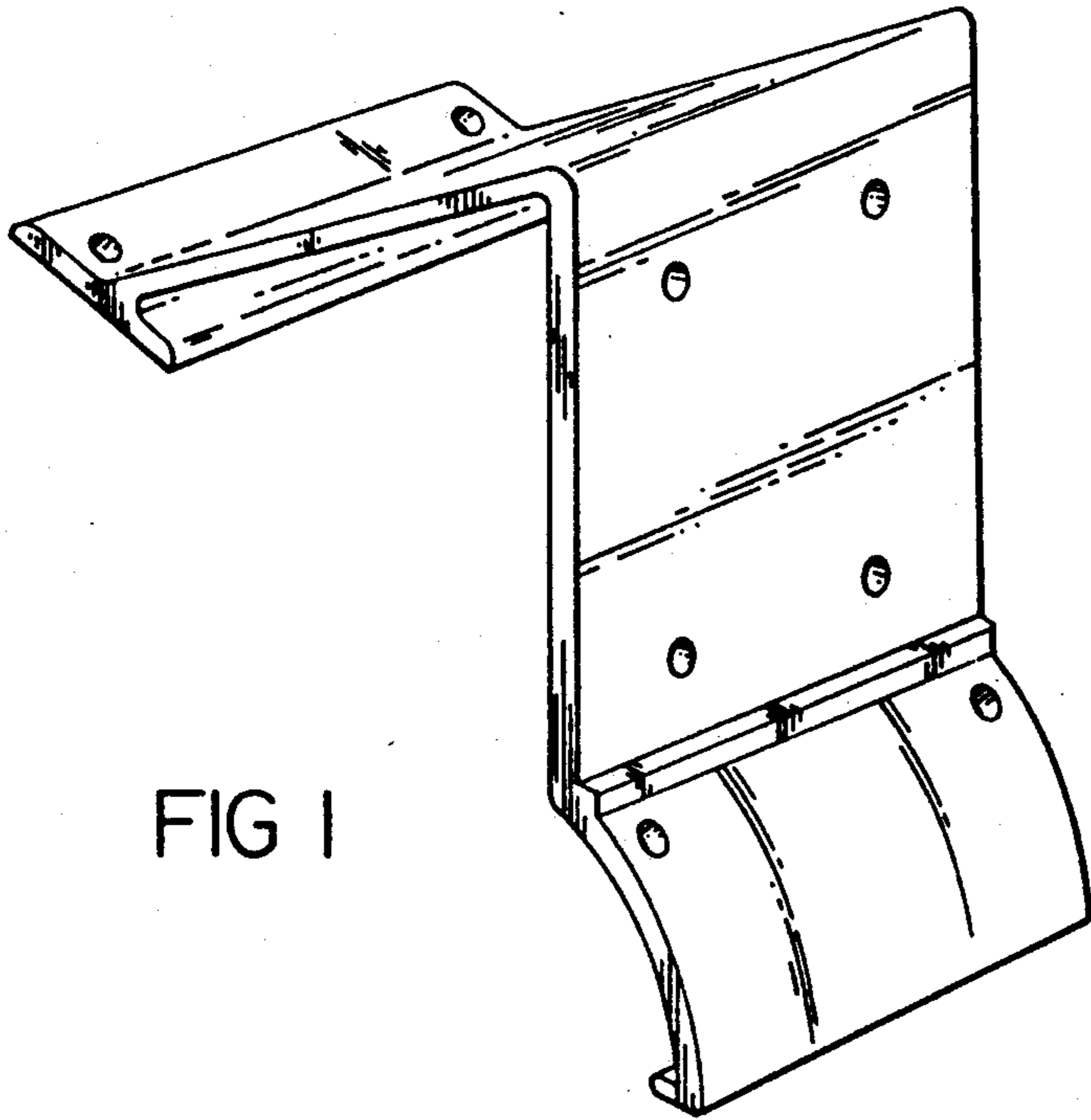

FIG 1

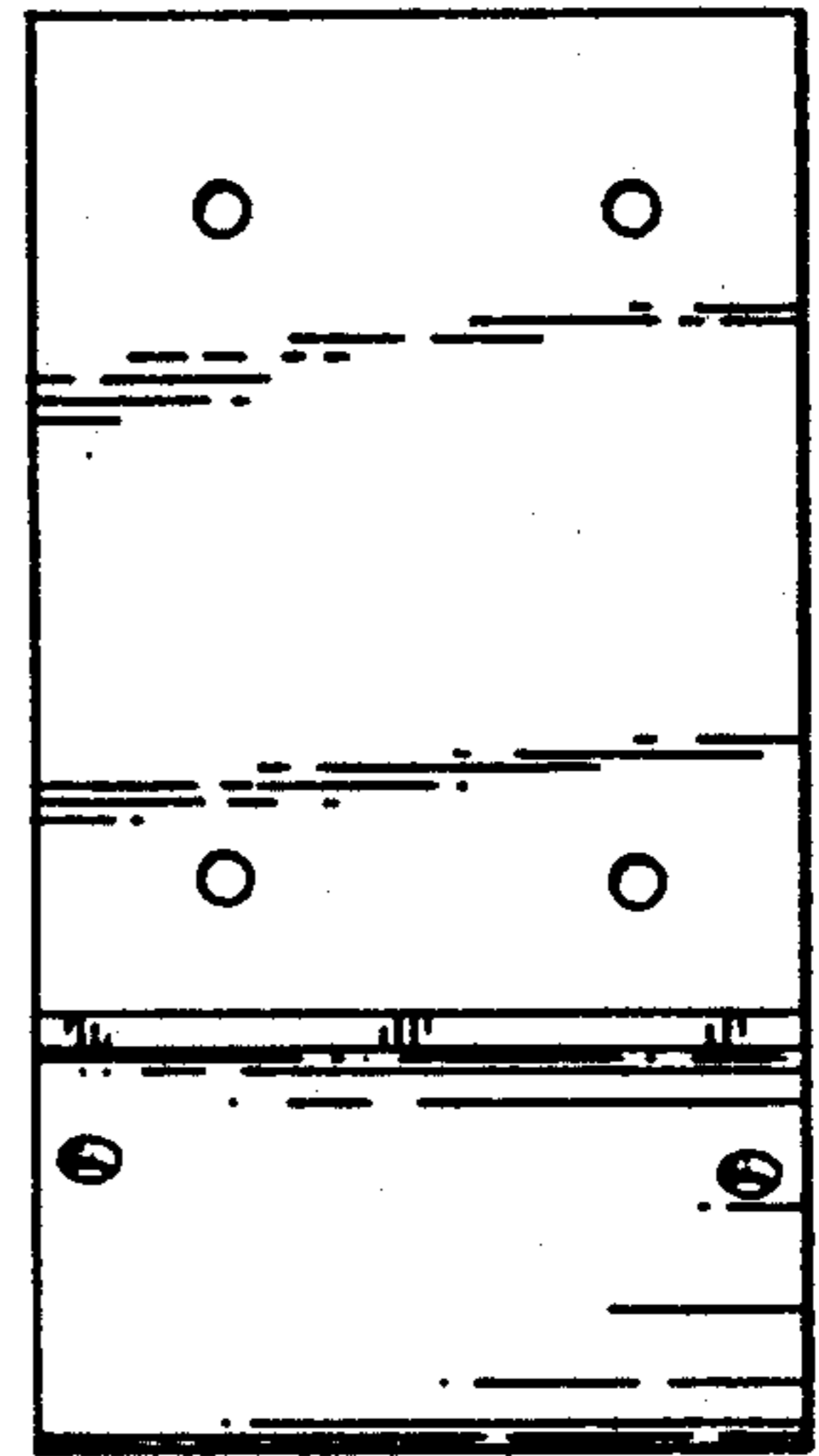

FIG 2

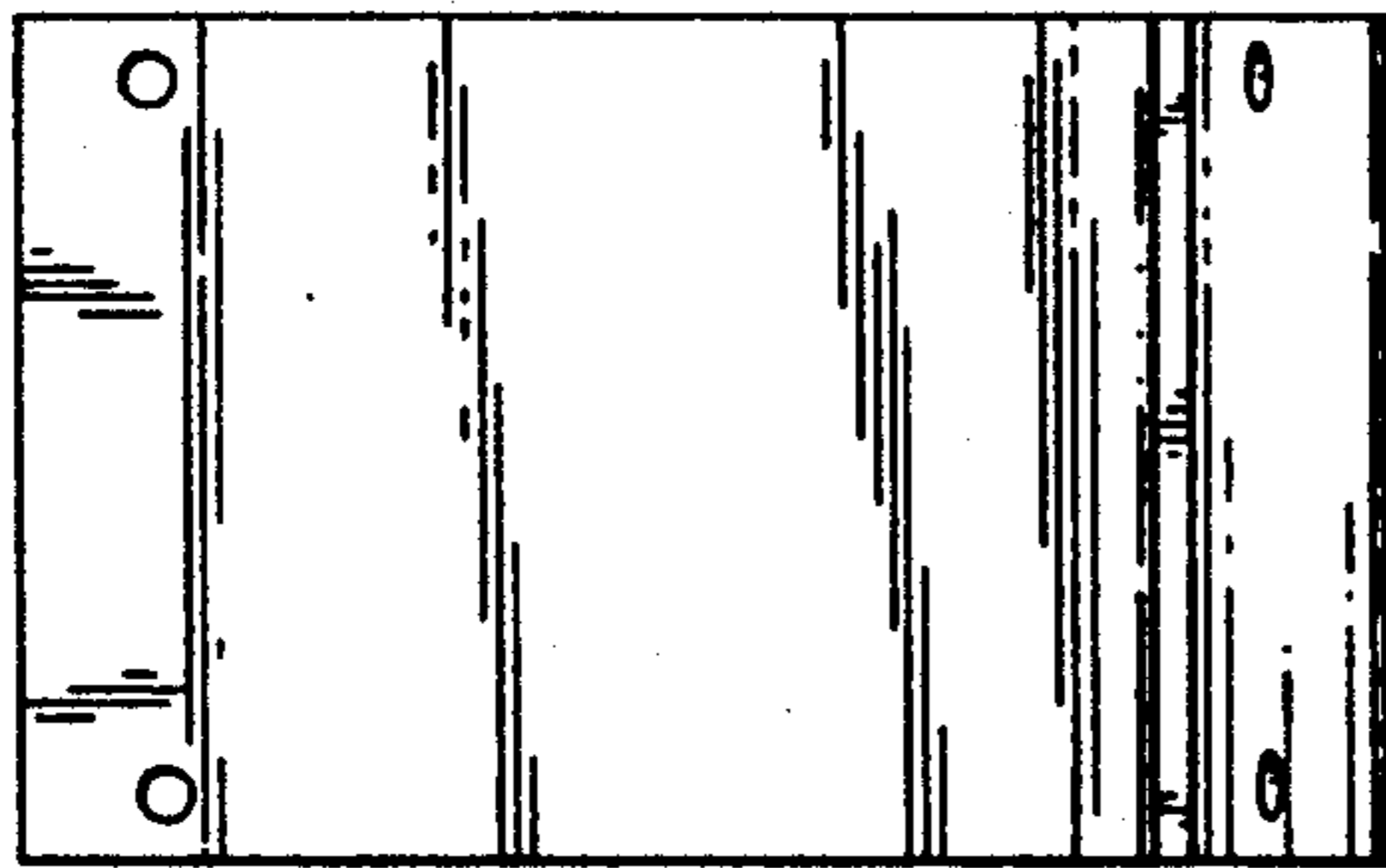

FIG 3

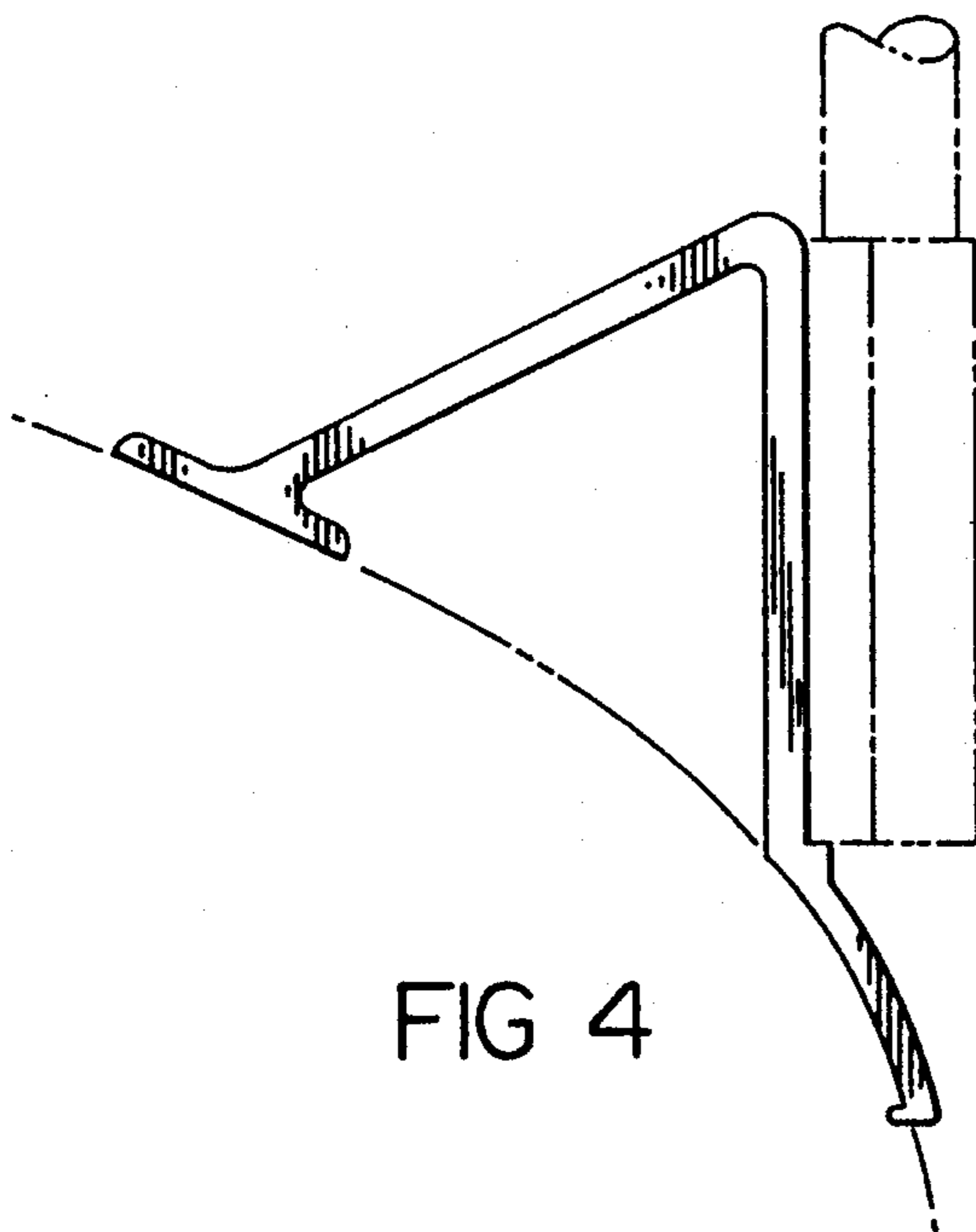

FIG 4

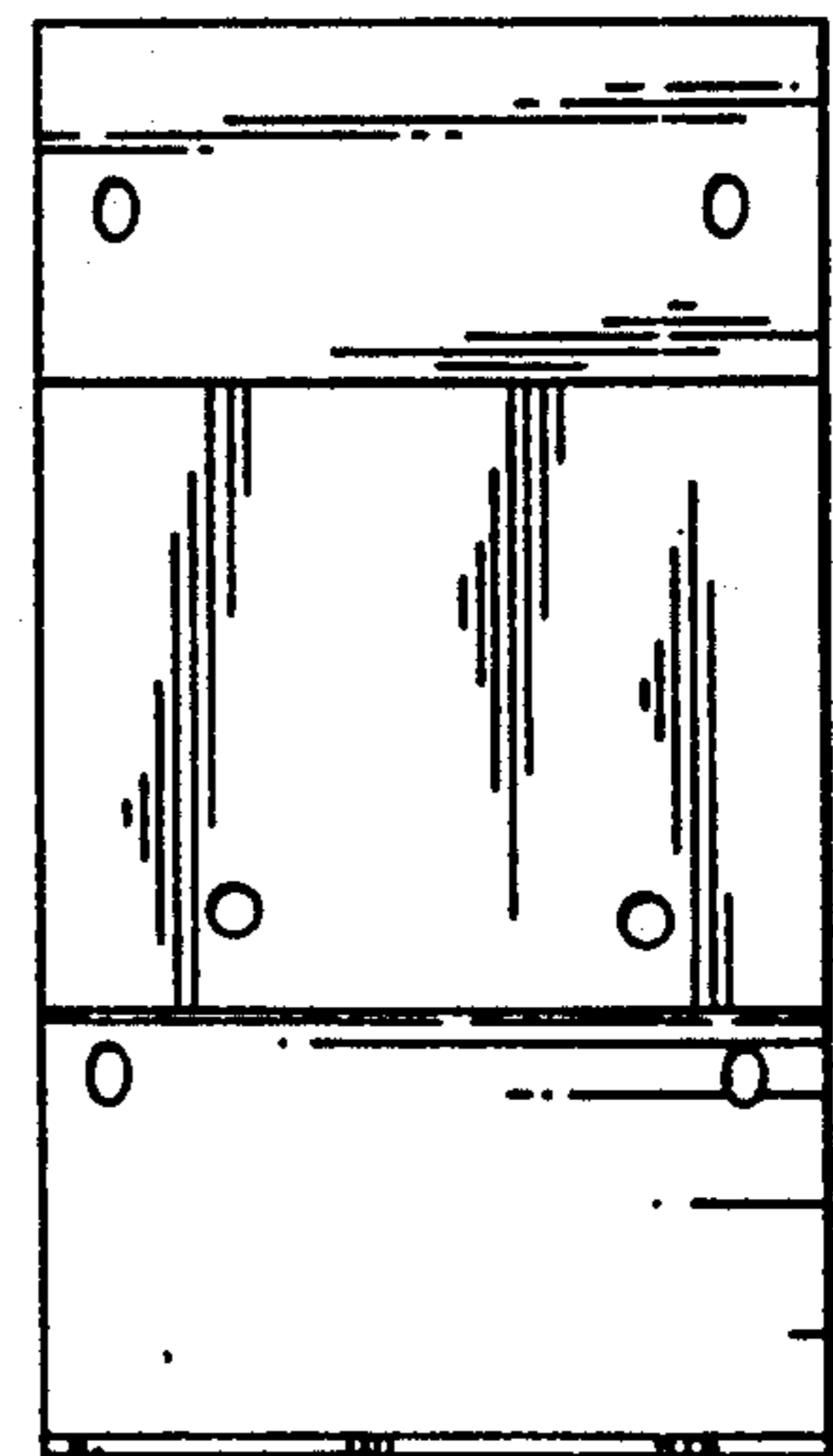

FIG 5