



US00D338634S

United States Patent [19]

[11] Patent Number: Des. 338,634

Axe

[45] Date of Patent: ** Aug. 24, 1993

[54] PRESSURE TESTER FOR ENGINE HEADS

[56] References Cited

[75] Inventor: Danny W. Axe, Council Grove, Kans.

U.S. PATENT DOCUMENTS

D. 271,570 11/1983 Cain D10/83
4,213,328 7/1980 Roeschlaub et al. 73/49.7

[73] Assignee: Custom Sheet and Steel Fabricators, Inc., Council Grove, Kans.

Primary Examiner—Alan P. Douglas
Assistant Examiner—Antoine D. Davis
Attorney, Agent, or Firm—Shook, Hardy & Bacon

[**] Term: 14 Years

[57] CLAIM

The ornamental design for a pressure tester for engine heads, as shown and described.

[21] Appl. No.: 770,298

DESCRIPTION

[22] Filed: Oct. 1, 1991

[52] U.S. Cl. D10/83; D10/85

[58] Field of Search D10/83-85;
73/49.7, 115, 431; 141/367; 285/12

FIG. 1 is a front elevational view of a pressure tester for engine heads according to the present invention; FIG. 2 is a side elevational view thereof; FIG. 3 is a side elevational view showing the opposite side thereof; FIG. 4 is a rear elevational view thereof; and, FIG. 5 is a top plan view thereof.

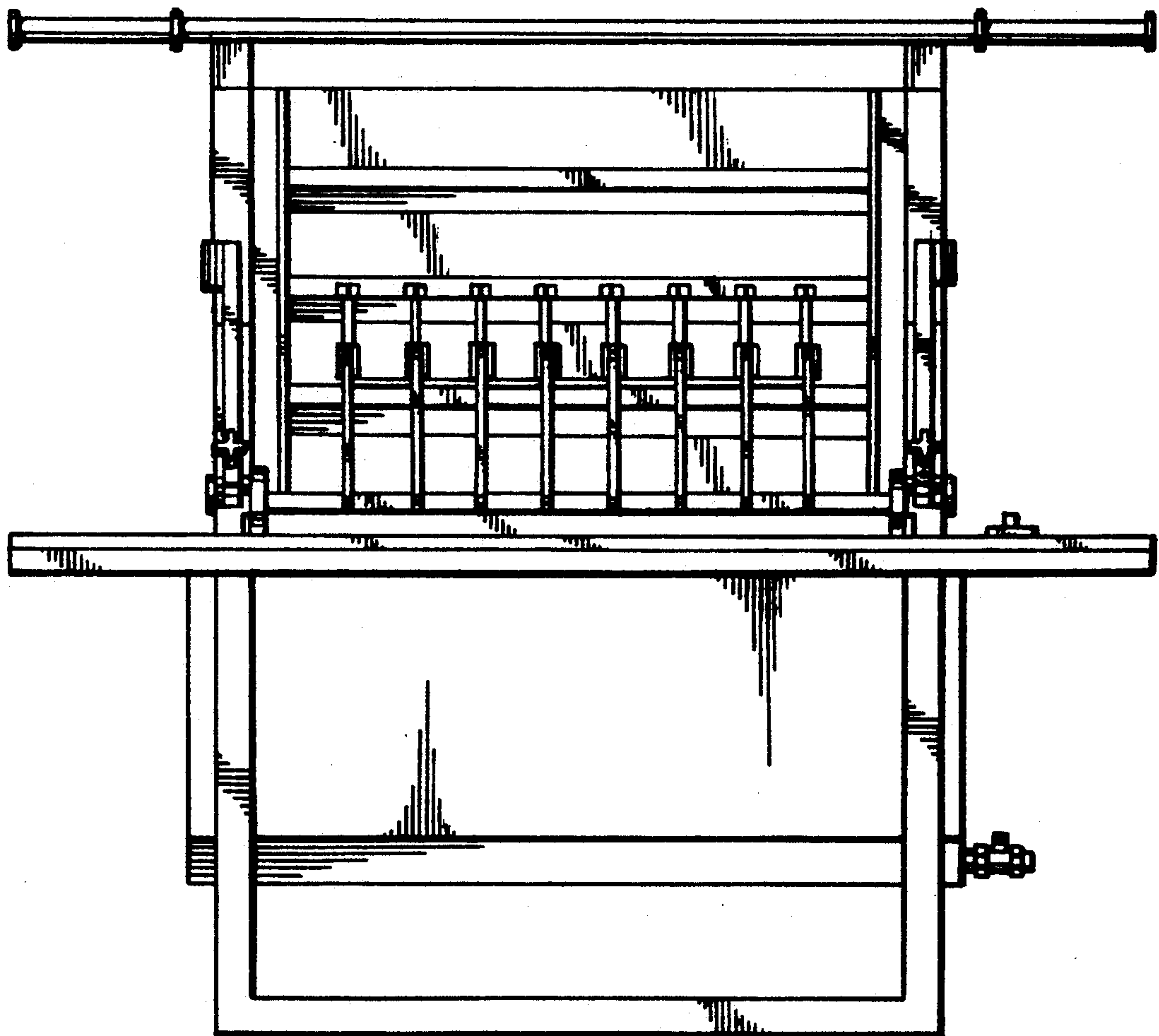

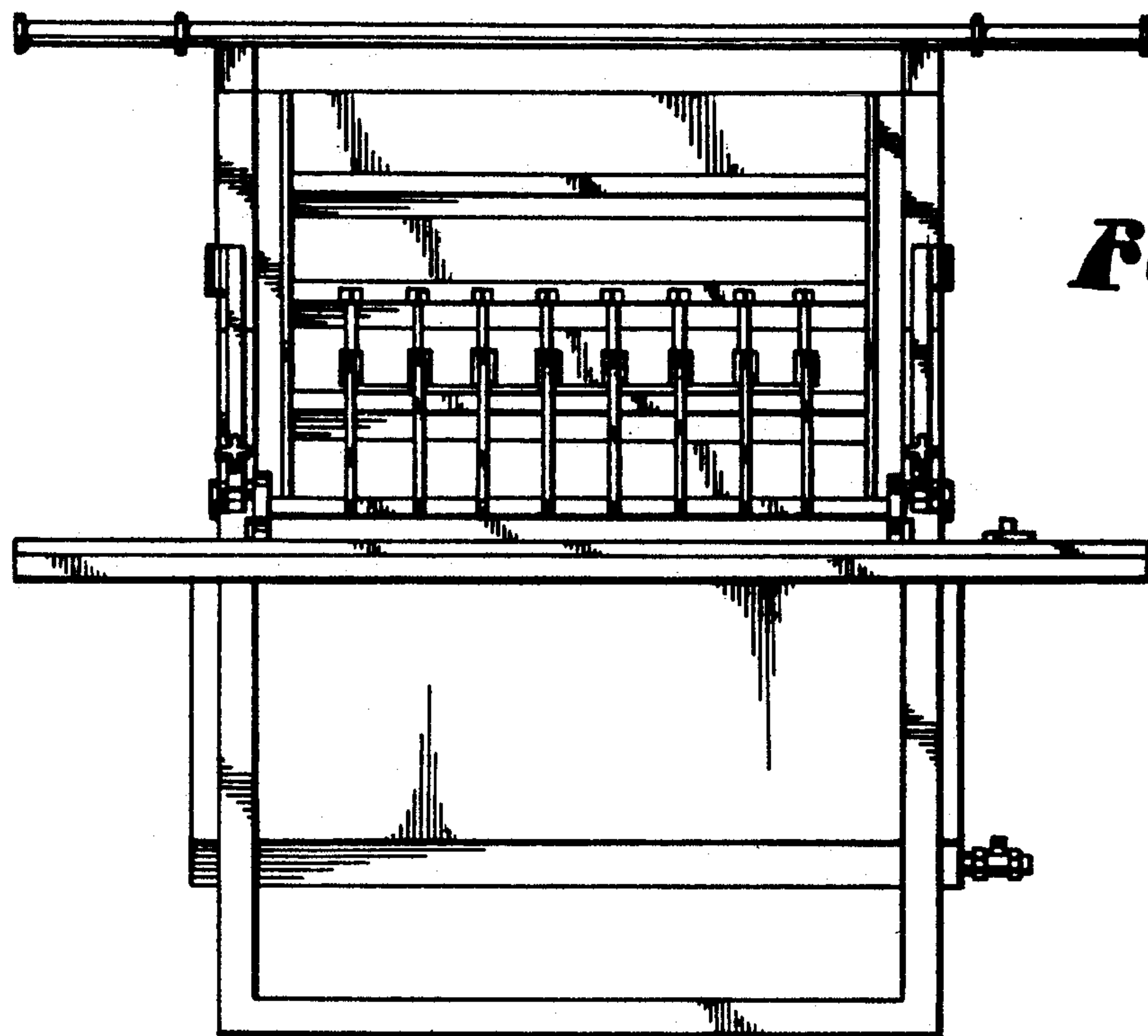

Fig. 1.

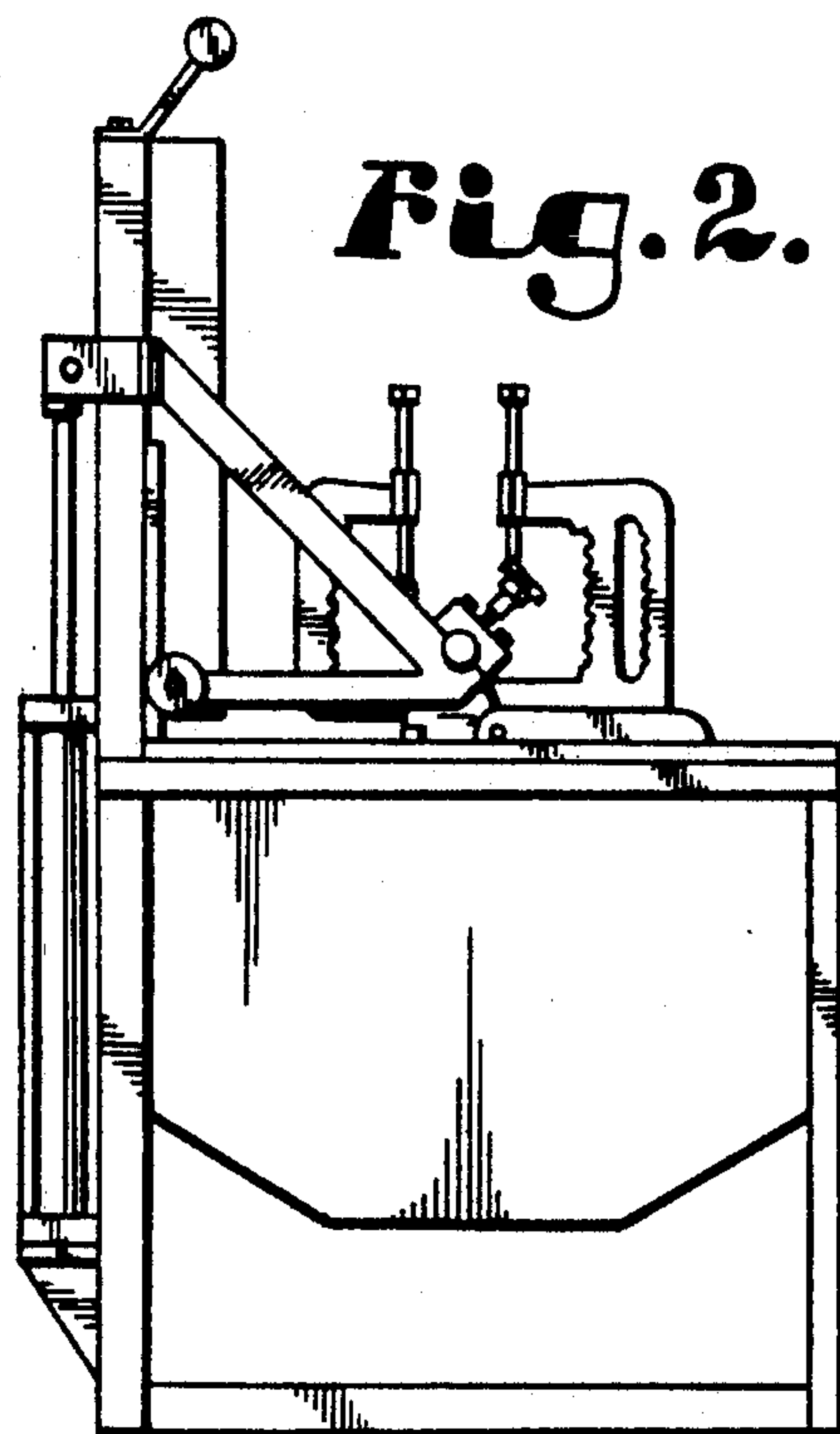

Fig. 2.

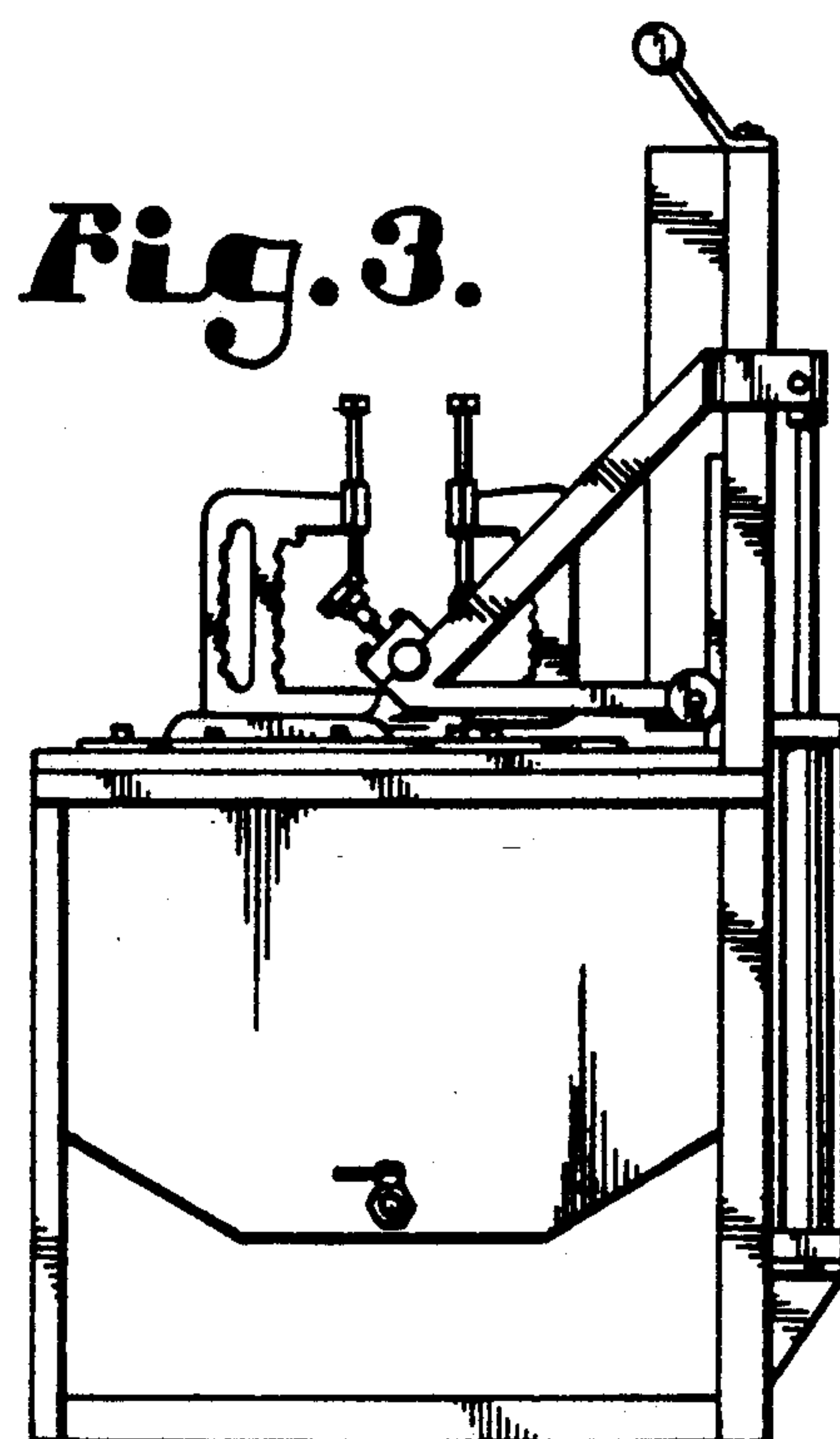

Fig. 3.

Fig. 4.

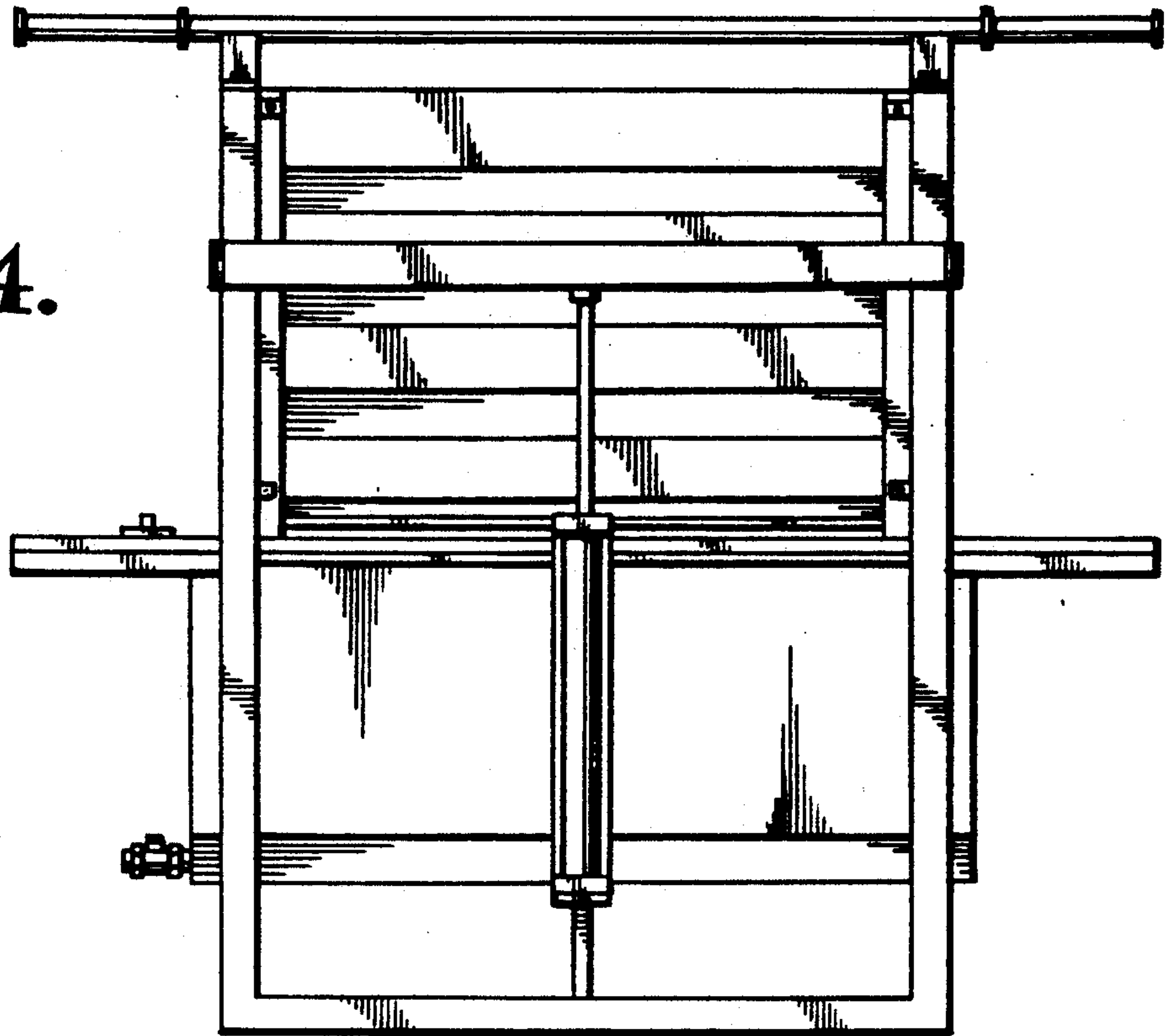

Fig. 5.

