



US00D338345S

United States Patent [19]

[11] Patent Number: **Des. 338,345**

Camp

[45] Date of Patent: **** Aug. 17, 1993**

[54] **COLLAPSIBLE SEAT**

[75] Inventor: **George Camp, High River, Canada**

[73] Assignee: **Sports Seats Unlimited Corporation, Calgary, Canada**

[**] Term: **14 Years**

[21] Appl. No.: **507,052**

[22] Filed: **Apr. 10, 1990**

[52] U.S. Cl. **D6/363; D6/335; D6/353; D6/368**

[58] Field of Search **D6/334, 335, 349, 353, D6/354, 355, 363, 368, 373, 374, 499, 500, 501; 135/66; 297/16, 118, 129**

[56] **References Cited**

U.S. PATENT DOCUMENTS

D. 284,429	7/1986	Garde	D6/363 X
542,609	7/1895	Gordon et al.	135/66 X
2,542,040	2/1951	MacLellan	D6/353 X
2,649,140	8/1953	Housel	D6/368 X
2,722,973	11/1955	Murcott	D6/349 X
3,310,340	3/1967	Brewer et al.	297/16

OTHER PUBLICATIONS

Industrial Design, Nov./Dec. 1977, p. 47, stool at bottom left.

Schöner Wohnen, Jun. 1984, p. 88, stool at bottom right.

Schöner Wohnen, Jul. 1987, p. 94, stool at bottom left.

Primary Examiner—Alan P. Douglas

Assistant Examiner—Gary D. Watson

Attorney, Agent, or Firm—Fetherstonhaugh & Co.

[57] **CLAIM**

The ornamental design for a collapsible seat, as shown and described.

DESCRIPTION

FIG. 1 is a right-front perspective view of a collapsible seat showing my new design;

FIG. 2 is a front elevational view;

FIG. 3 is a right side elevational view;

FIG. 4 is a left side elevational view;

FIG. 5 is a top plan view;

FIG. 6 is a rear elevational view; and,

FIG. 7 is a bottom plan view thereof.

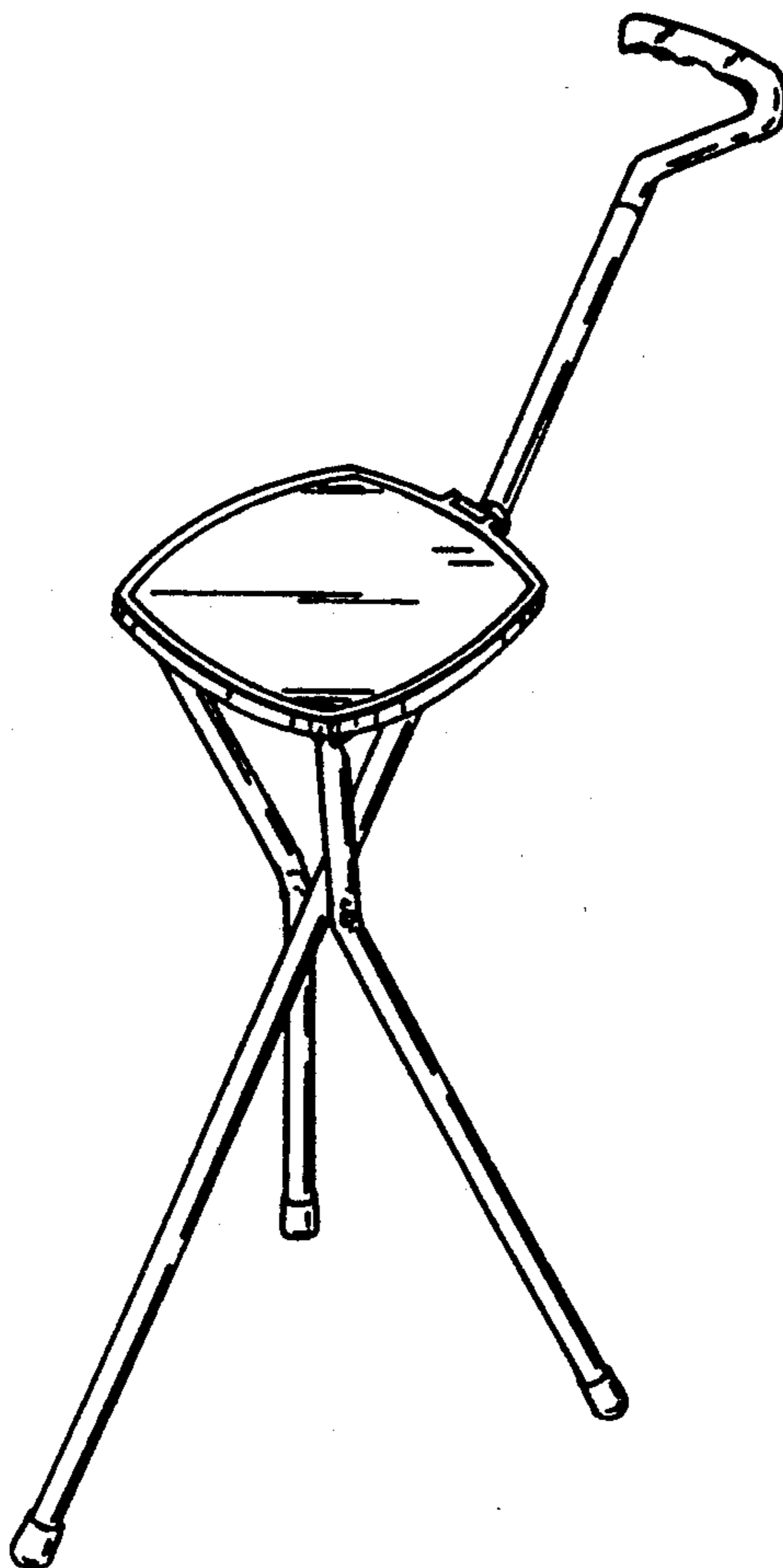

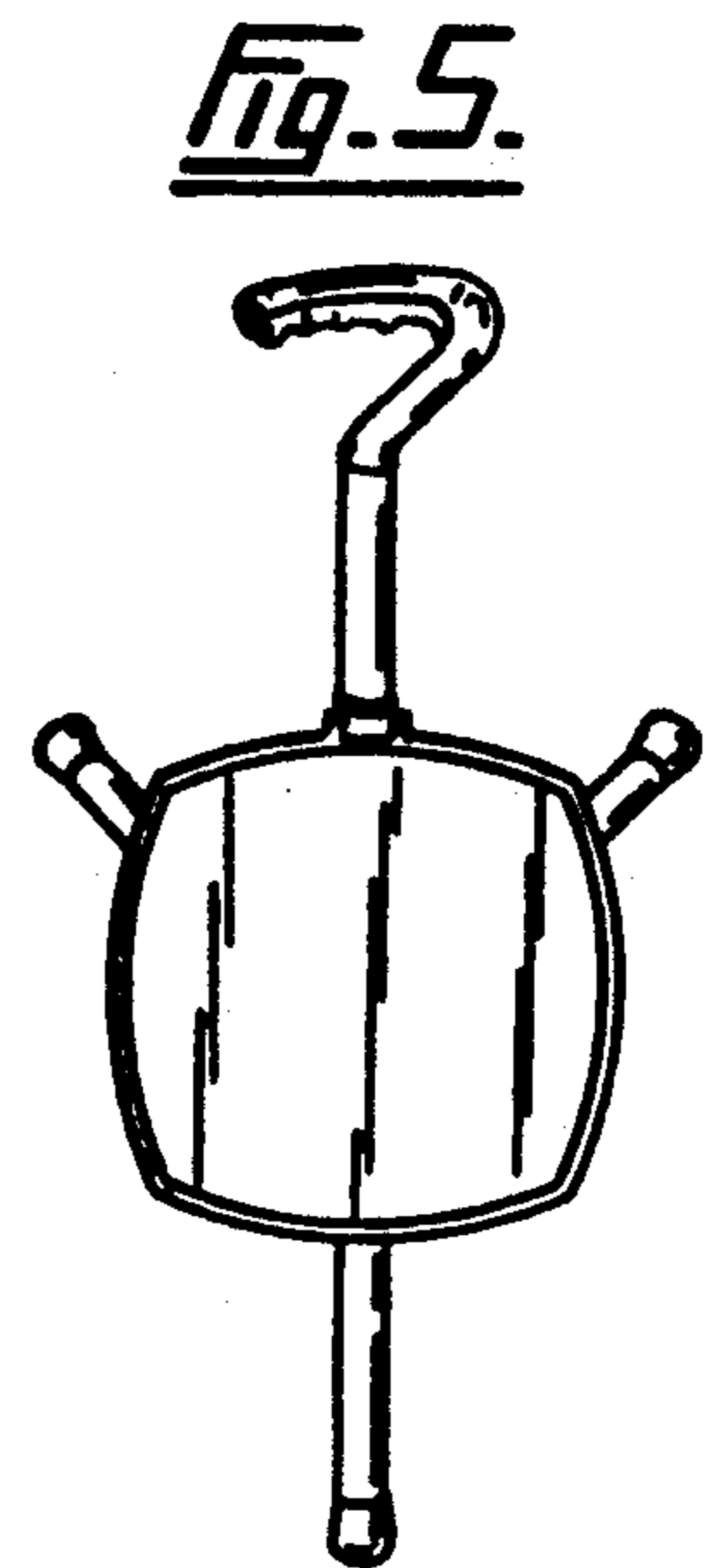
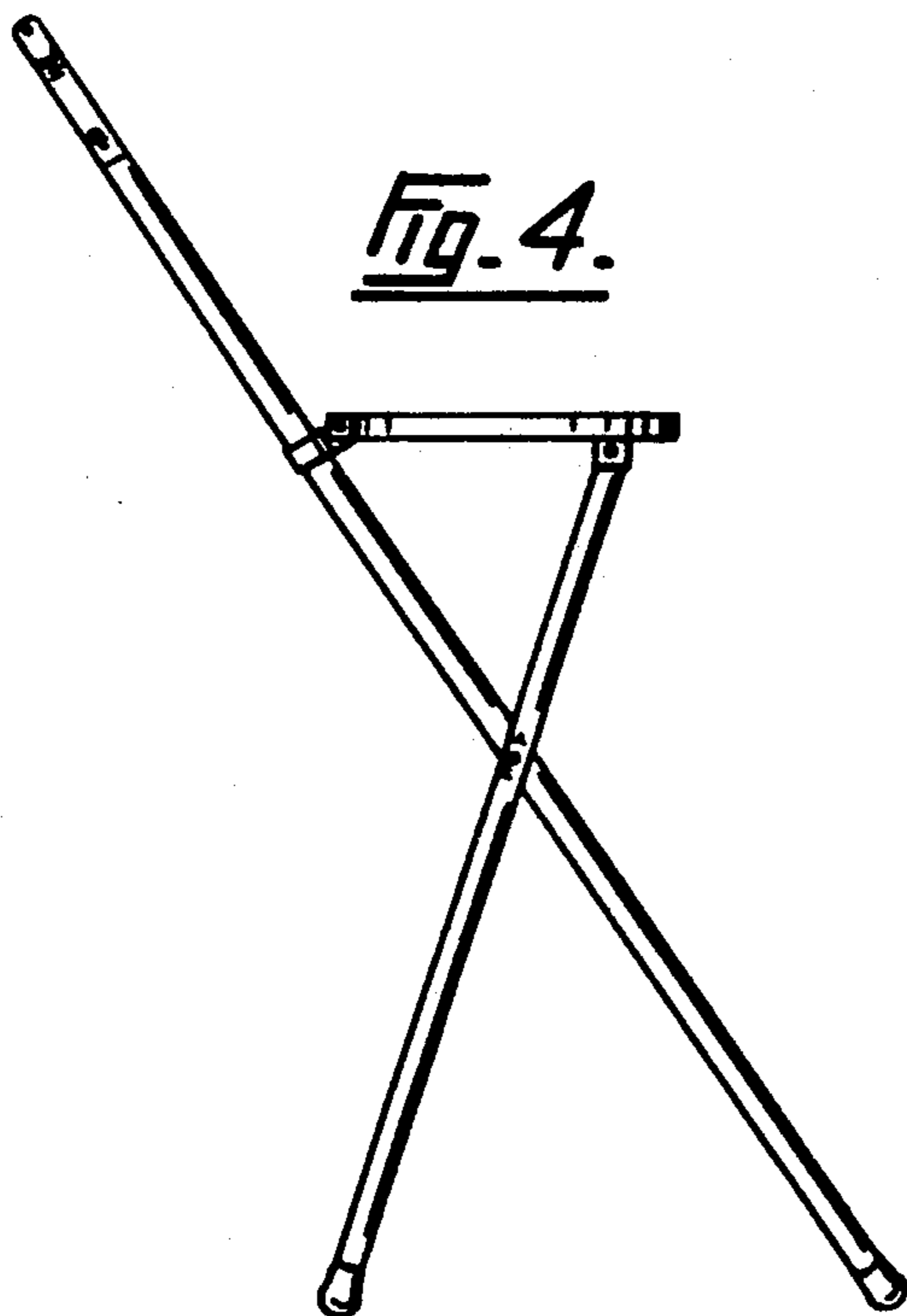
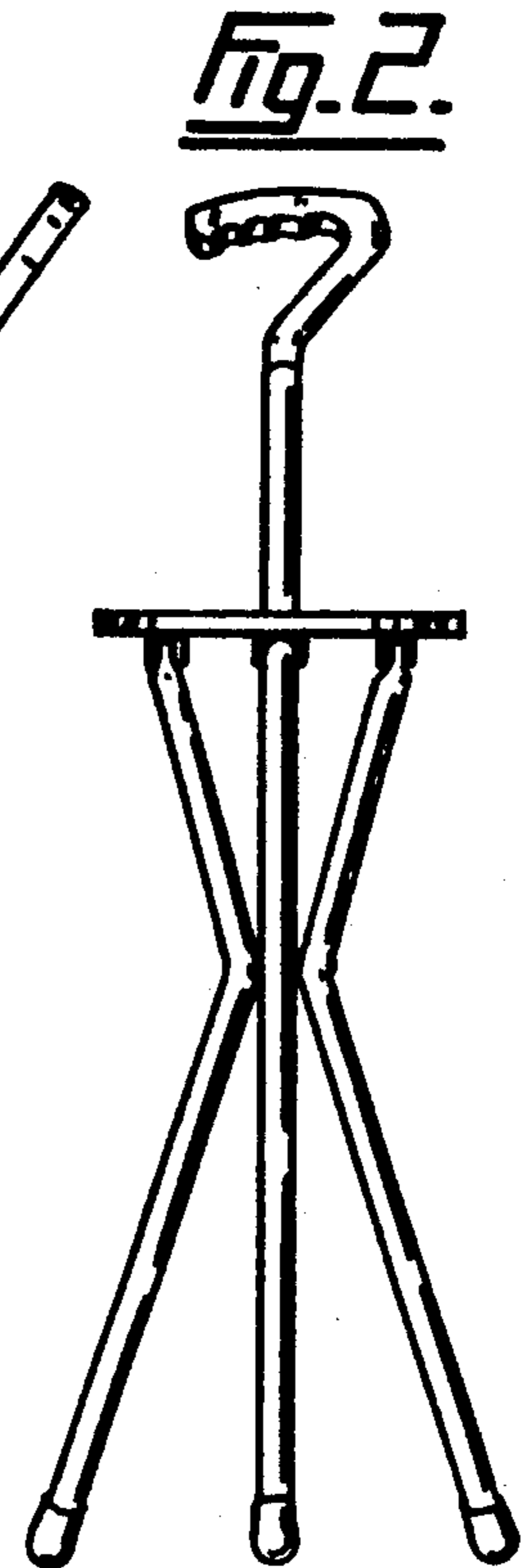
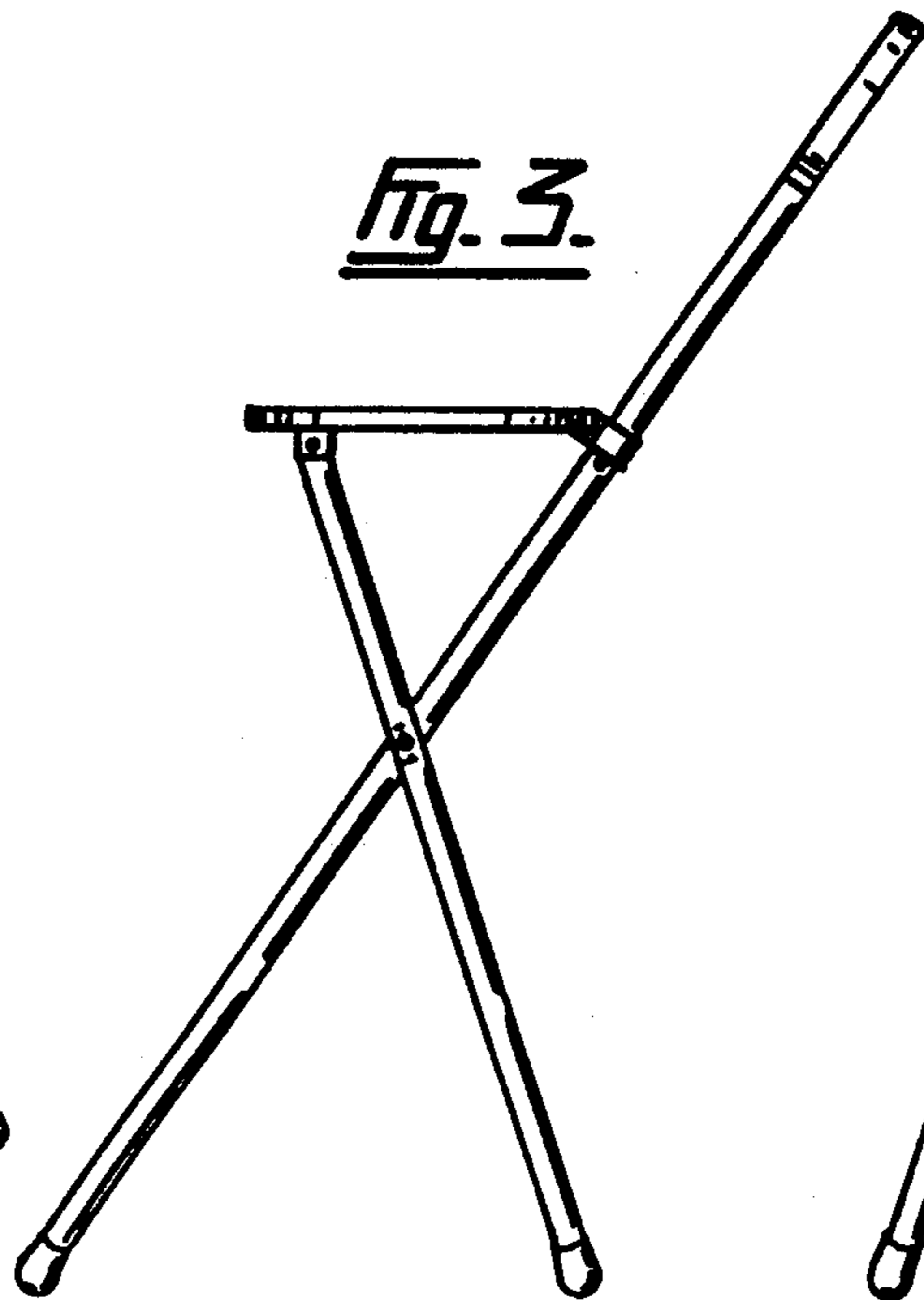
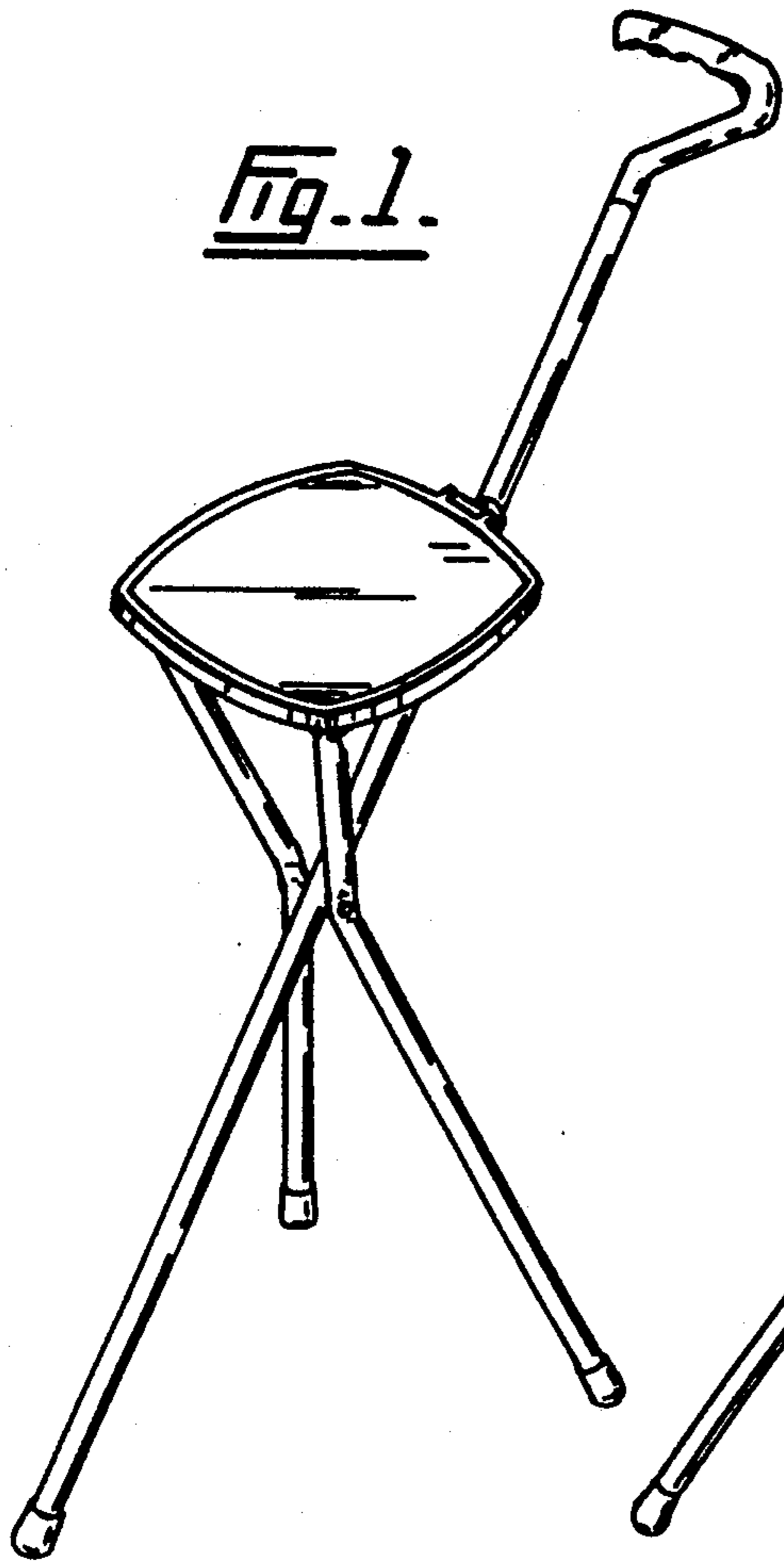

Fig. 6.

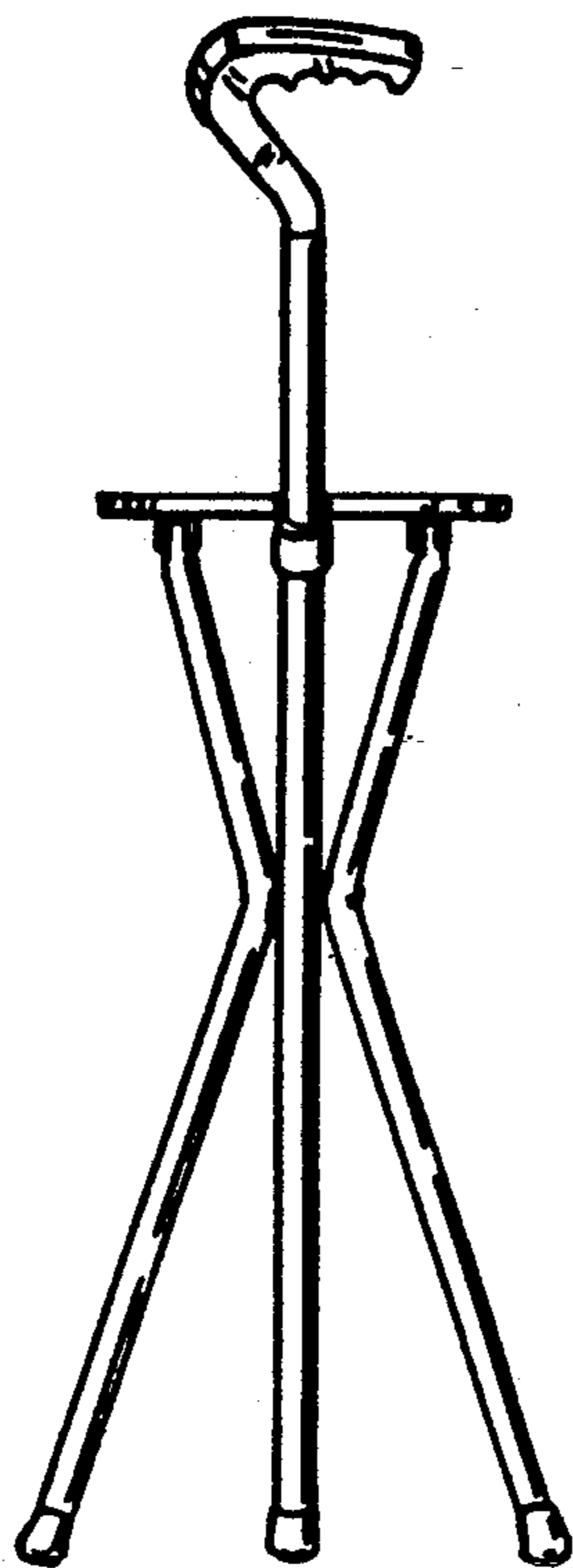

Fig. 7.

