



US00D338323S

# United States Patent [19]

[11] Patent Number: **Des. 338,323**

**Bramble**

[45] Date of Patent: **\*\* Aug. 17, 1993**

[54] **SHOE STRETCHER**

[76] Inventor: **Elizabeth Bramble**, 701 S. Valderas St., Angleton, Tex. 77575-5232

[\*\*] Term: **14 Years**

[21] Appl. No.: **506,893**

[22] Filed: **Apr. 10, 1990**

[52] U.S. Cl. .... **D2/314.1**

[58] Field of Search ..... **D2/314.1; 12/115.8, 12/115.6, 128 R, 128 B, 128 C, 128 H, 128 D, 128 E, 128 F, 135 A, 116.6**

[56] **References Cited**

### U.S. PATENT DOCUMENTS

D. 147,156	7/1947	Sturm	.....	D2/314.1
D. 178,828	9/1956	Conradi	.....	D2/314.1
D. 245,204	7/1977	Walter	.....	D2/314.1
3,251,083	5/1966	Bay	.....	D2/314.1 X

*Primary Examiner*—Louis S. Zarfes  
*Attorney, Agent, or Firm*—Terry M. Gernstein

### [57] CLAIM

The ornamental design for a shoe stretcher, as shown and described.

### DESCRIPTION

FIG. 1 is a perspective view of a shoe stretcher showing my new design;

FIG. 2 is a top plan view thereof;

FIG. 3 is an end elevational view thereof;

FIG. 4 is a bottom plan view thereof;

FIG. 5 is a side elevational view thereof, the side opposite being a mirror image of the side shown in FIG. 5; and,

FIG. 6 is a bottom perspective view thereof.

The broken line showing of a cover is for illustrative purposes only and forms no part of the claimed design.

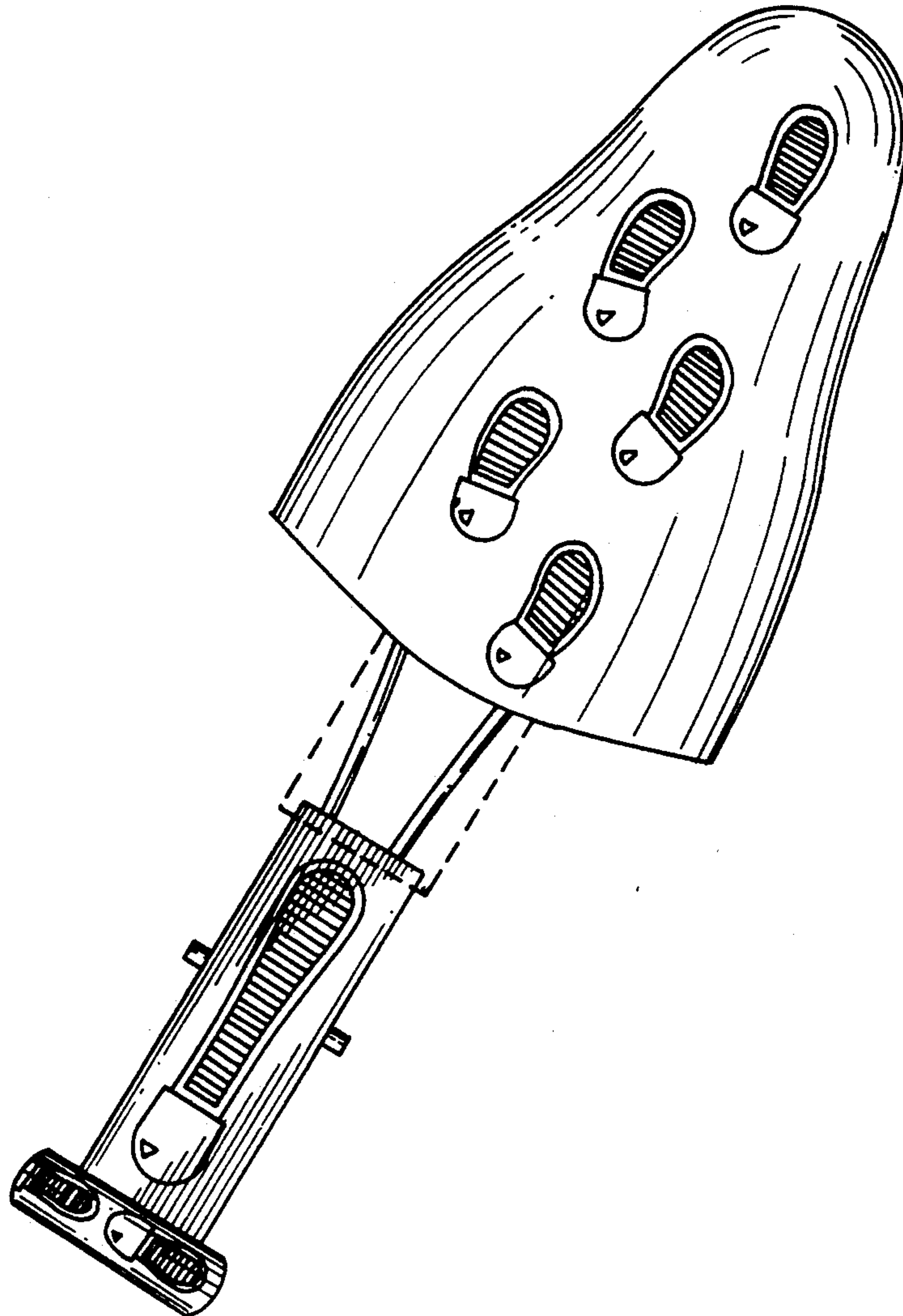

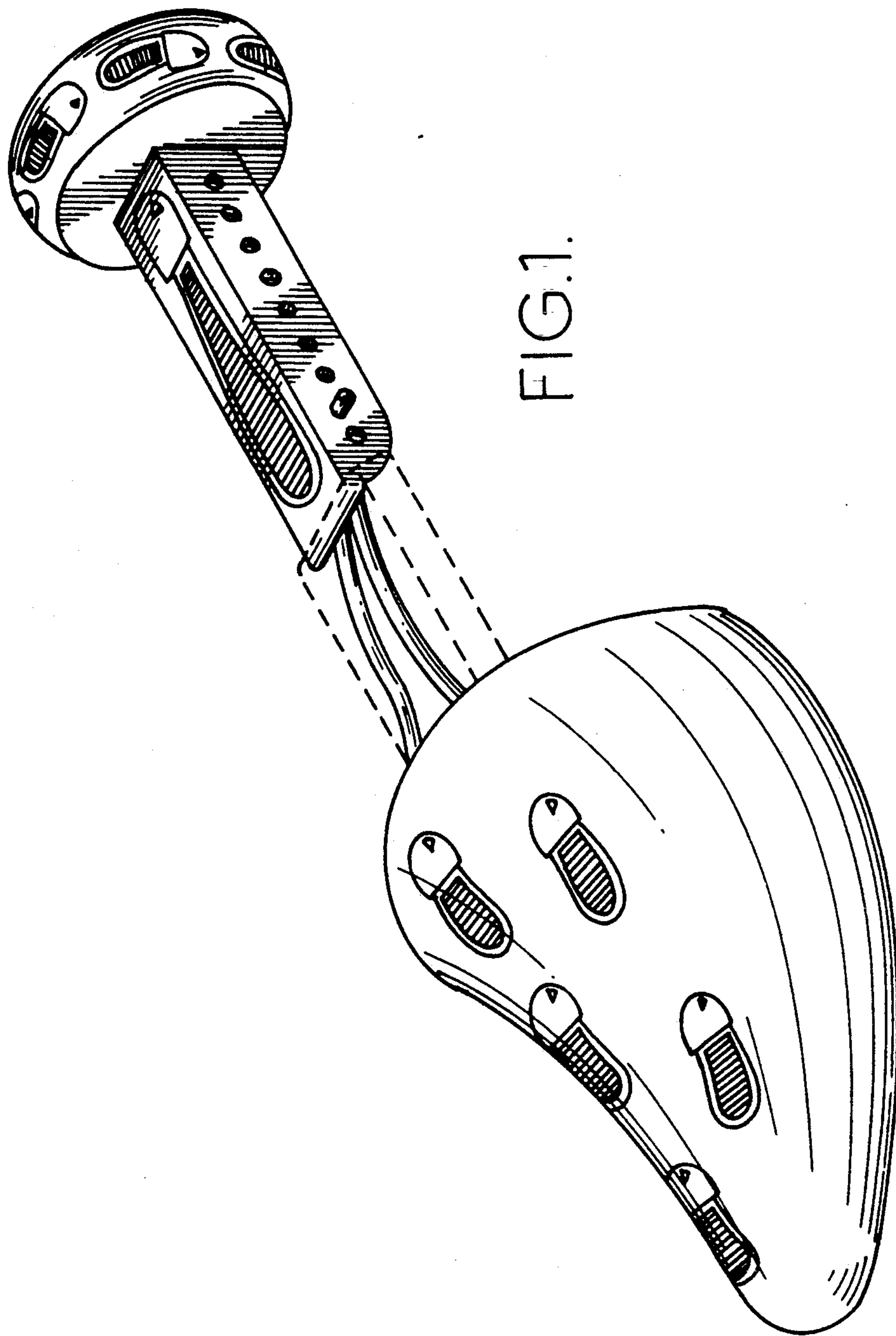

FIG. 1.

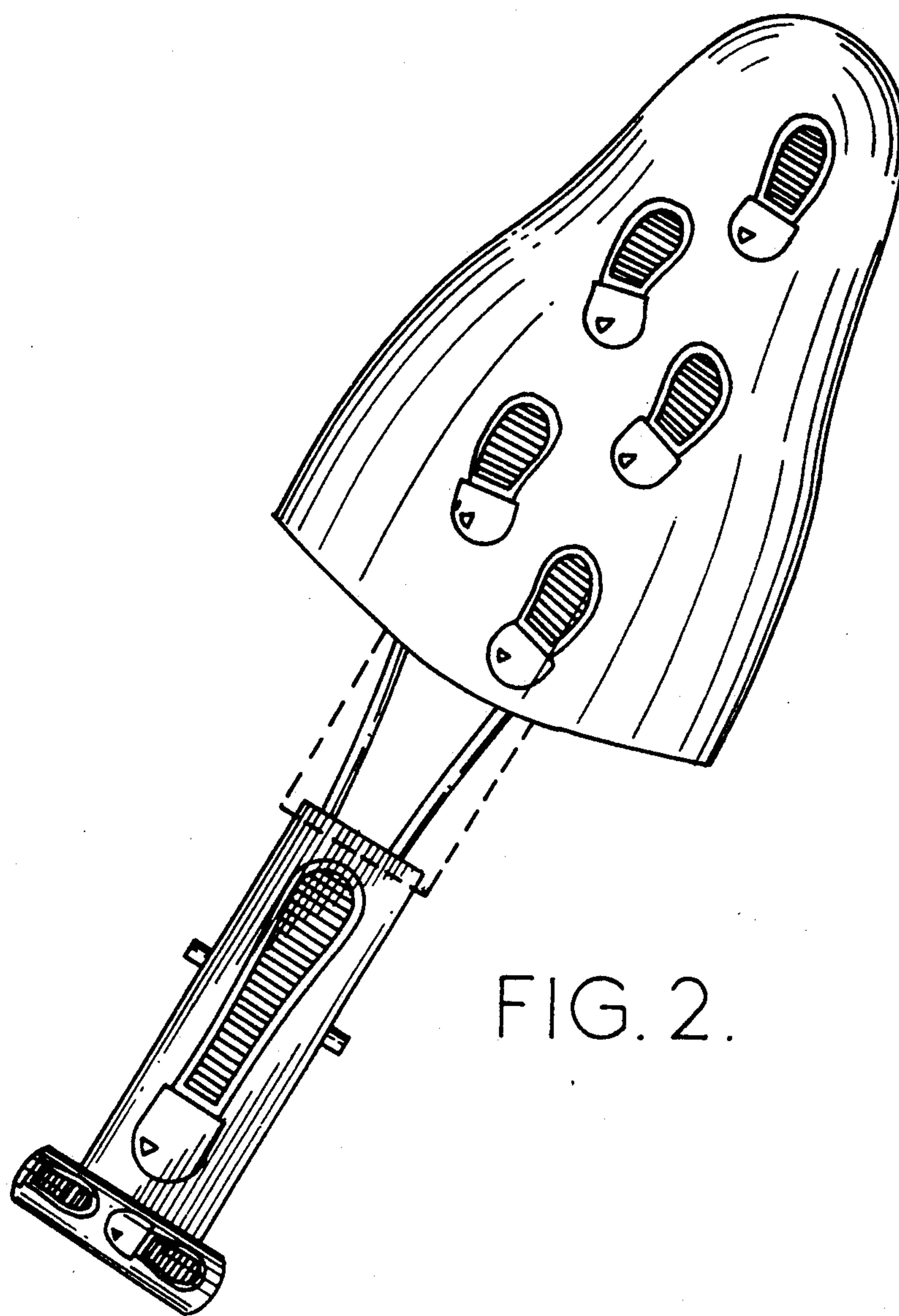

FIG. 2.

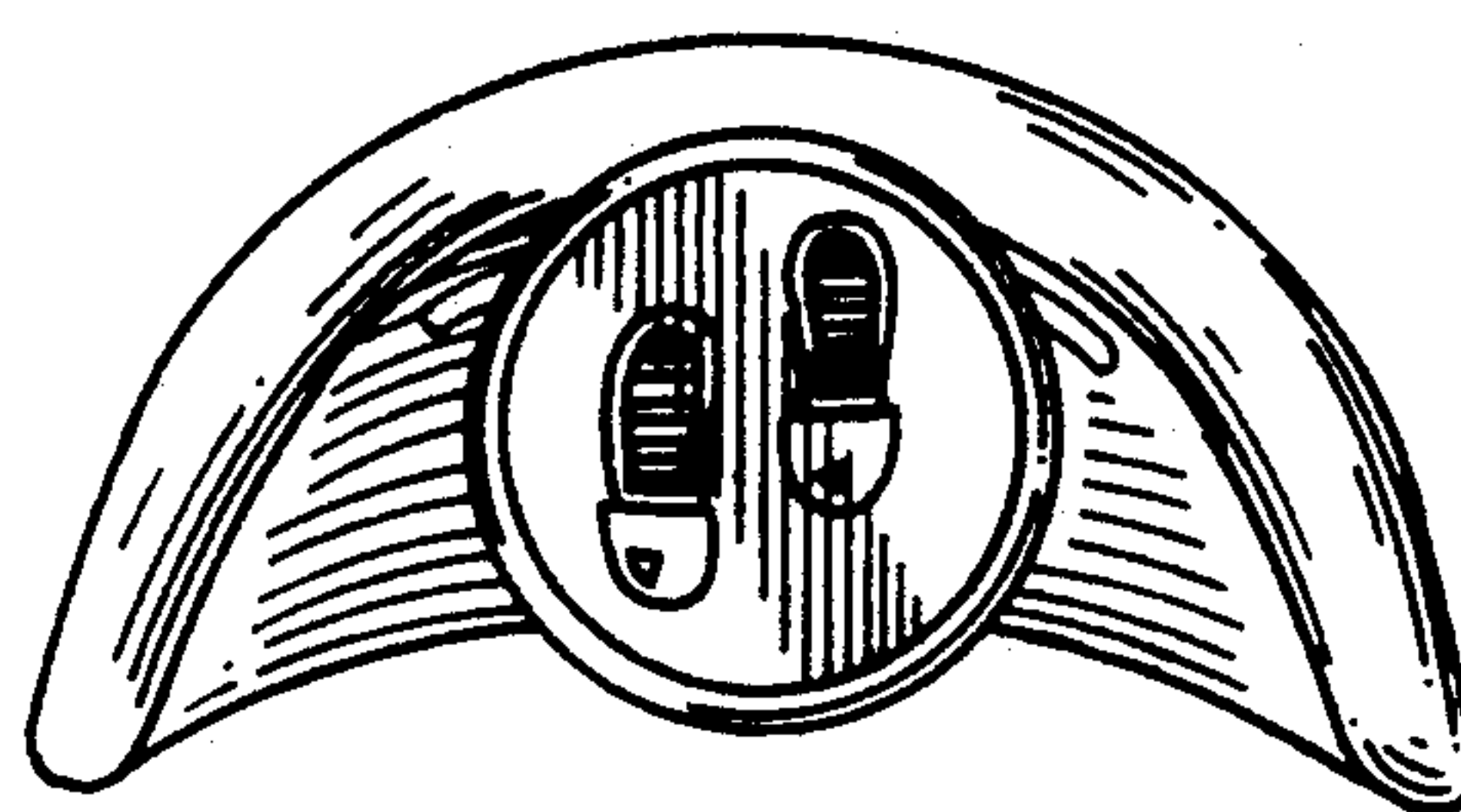

FIG. 3.

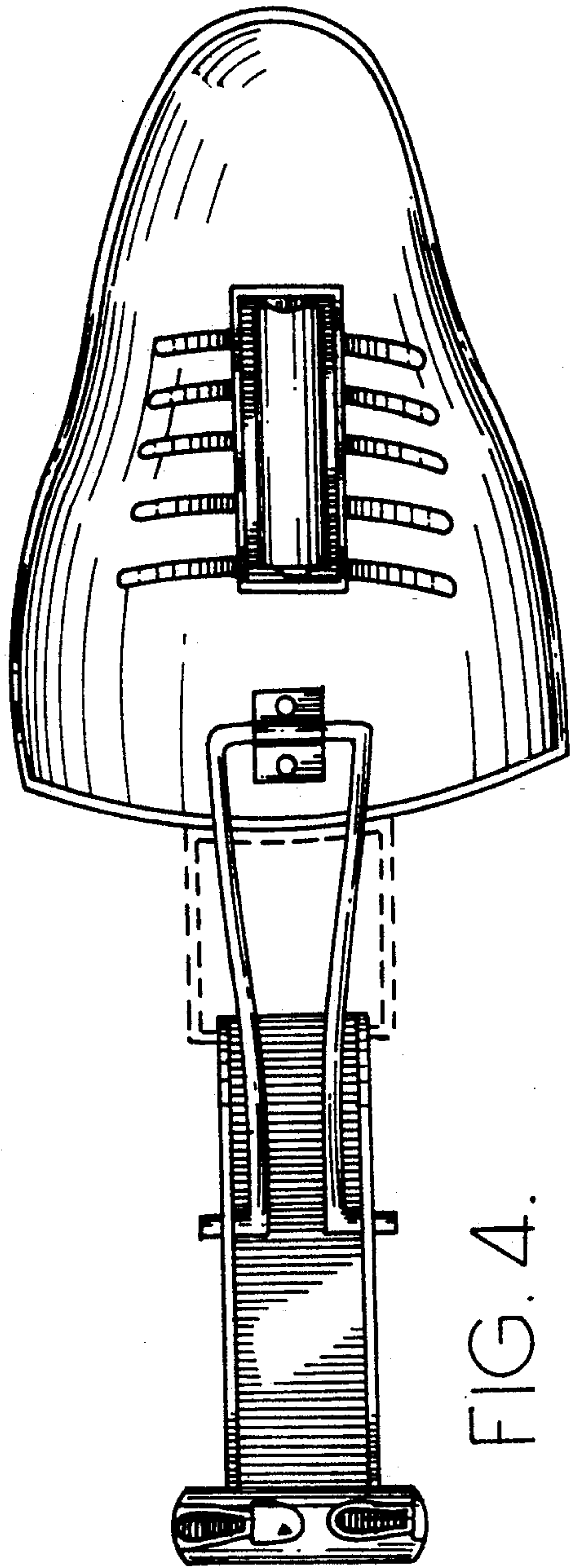

FIG. 4.

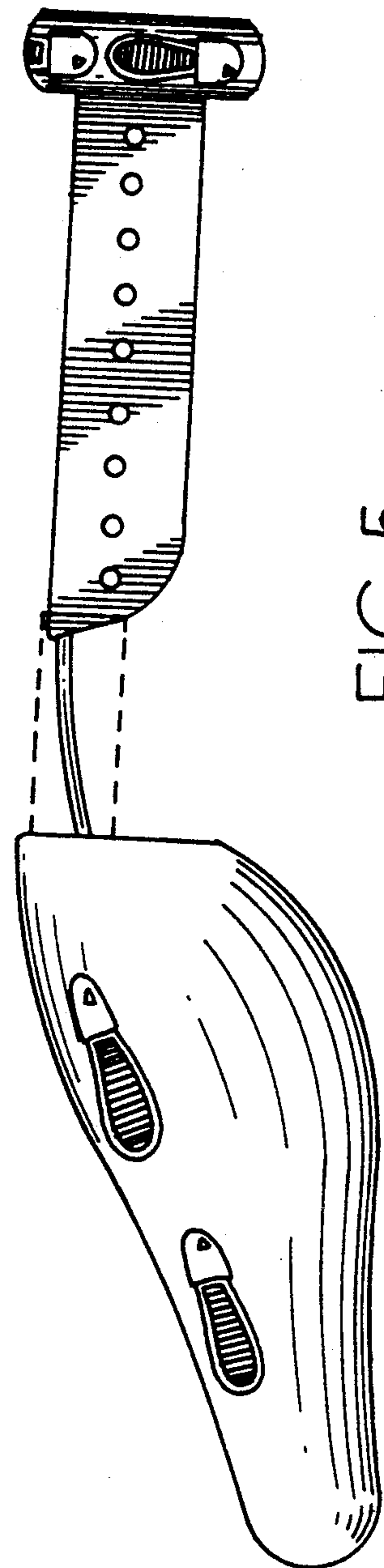

FIG. 5.



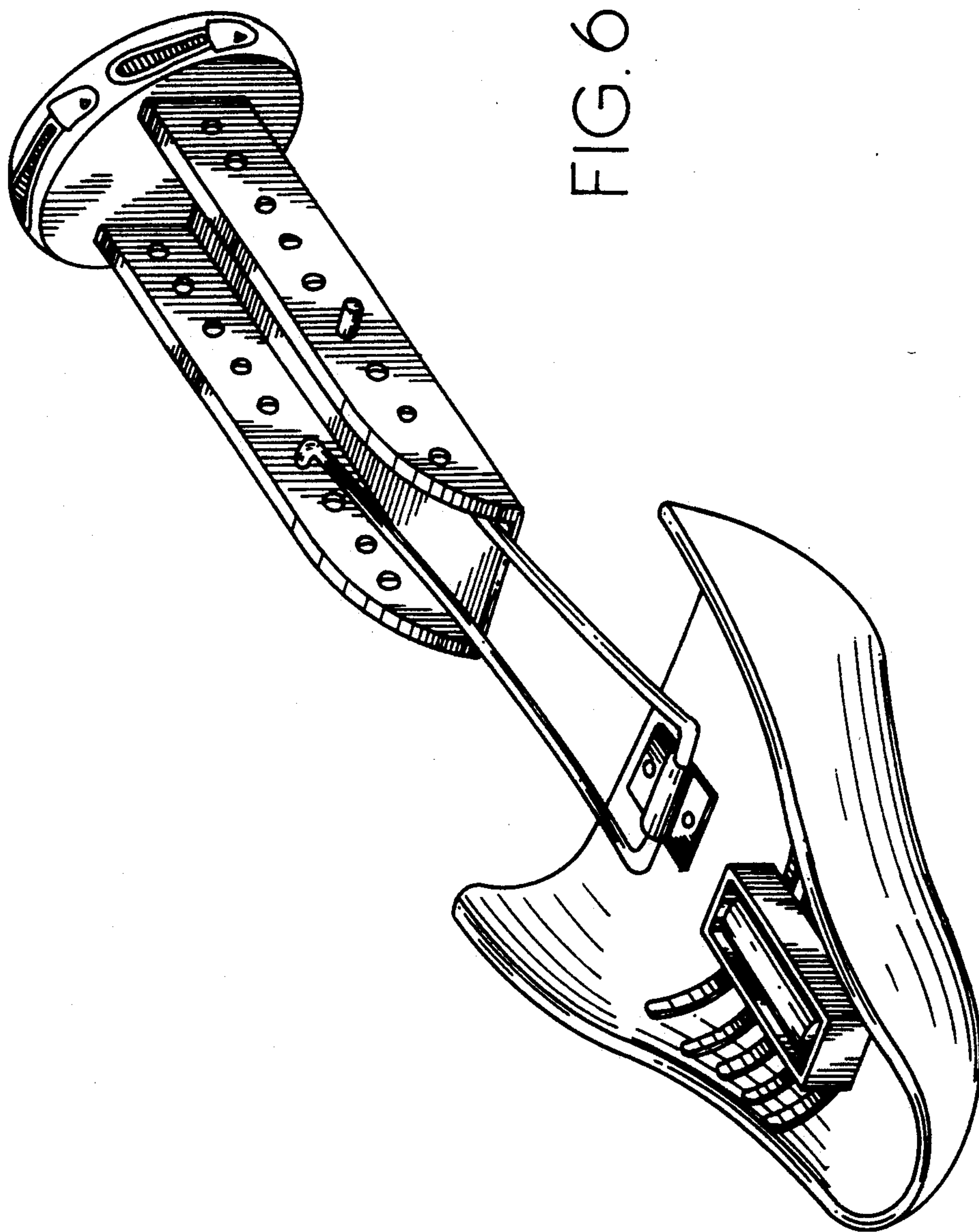

FIG. 6.