



US00D338191S

# United States Patent [19]

[11] Patent Number: **Des. 338,191**

Ahmed et al.

[45] Date of Patent: **\*\* Aug. 10, 1993**

[54] **POWER SEAT CONTROL UNIT FOR VEHICULAR DRIVER AND PASSENGER SEATS**

5,053,592 10/1991 Zuercher ..... 200/553

[75] Inventors: **Moin Ahmed, Madison Heights; Joseph J. Umpirowicz, Northville, both of Mich.**

### FOREIGN PATENT DOCUMENTS

0527179 11/1958 Belgium ..... 200/339

0477214 5/1936 United Kingdom ..... 220/241

2087154 5/1982 United Kingdom ..... 200/339

[73] Assignee: **Chrysler Corporation, Highland Park, Mich.**

### OTHER PUBLICATIONS

Switches on p. 4 of L'Elettortecnica, 9-85.

Rocker Switch panel on p. 121 of J. C. Whitney & Co.

[\*] Notice: The portion of the term of this patent subsequent to Jul. 21, 2006 has been disclaimed.

*Primary Examiner*—Wallace R. Burke

*Assistant Examiner*—Joel Sincavage

*Attorney, Agent, or Firm*—Wendell K. Fredericks

[\*\*] Term: **14 Years**

### [57] CLAIM

[21] Appl. No.: **521,474**

The ornamental design for a power seat control unit for vehicular driver and passenger seats, as shown and described.

[22] Filed: **May 9, 1990**

[52] U.S. Cl. .... **D13/162**

[58] Field of Search ..... D13/162, 163, 164, 169, D13/171; D14/100; D21/48; 200/5 R, 345, 314, 339, 553; 361/331, 358; 220/241; 174/52.1

### DESCRIPTION

### [56] References Cited

#### U.S. PATENT DOCUMENTS

- D. 186,944 12/1959 Everett ..... D13/162
- D. 266,415 10/1982 Cremer ..... D13/164
- D. 301,873 6/1989 Gutman ..... D13/171
- D. 304,721 11/1989 Mikan ..... D21/48 X
- D. 318,463 7/1991 Yomo ..... D14/100
- D. 321,215 10/1991 Shamis ..... D21/48
- 4,249,086 2/1981 Mochizuki ..... 200/345 X
- 4,710,597 12/1987 Loheac ..... 200/314 X
- 4,947,008 8/1990 Sato et al. .... 200/339 X
- 4,967,046 10/1990 Priesemuth ..... 200/315 X

FIG. 1 is a front and upper right perspective view of a power seat control unit for vehicular driver and passenger seats showing our new design. The broken line showing is included for the purpose of illustrating environmental elements only and forms no part of the claimed design;

FIG. 2 is a front elevational view of a power seat control unit for vehicular driver and passenger seats showing our new design on an enlarged scale;

FIG. 3 is a right side elevational view thereof, the left side elevational view thereof being a mirror image; and, FIG. 4 is a top plan view thereof.

The broken line showing is for illustrative purposes only and forms no part of the claimed design.

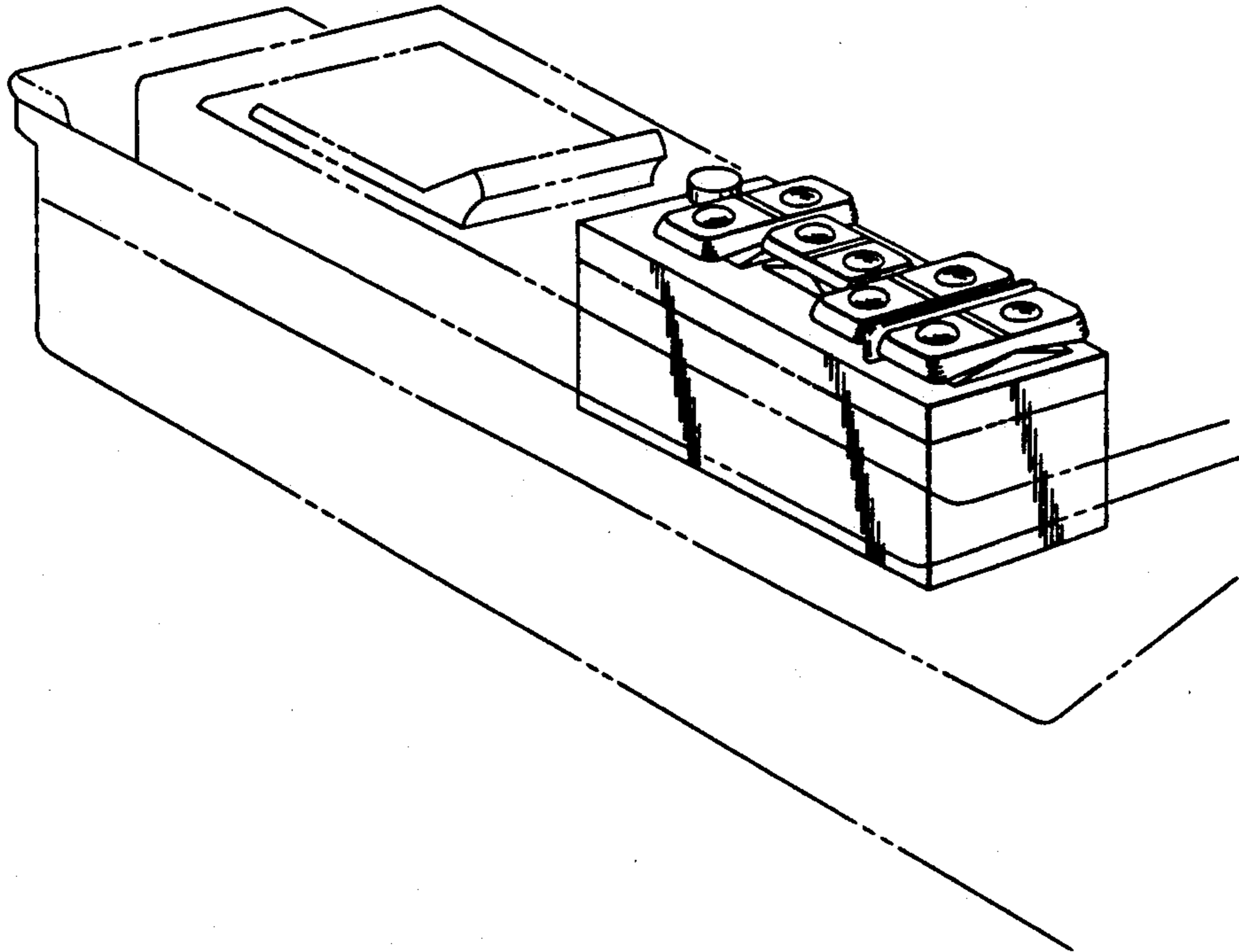

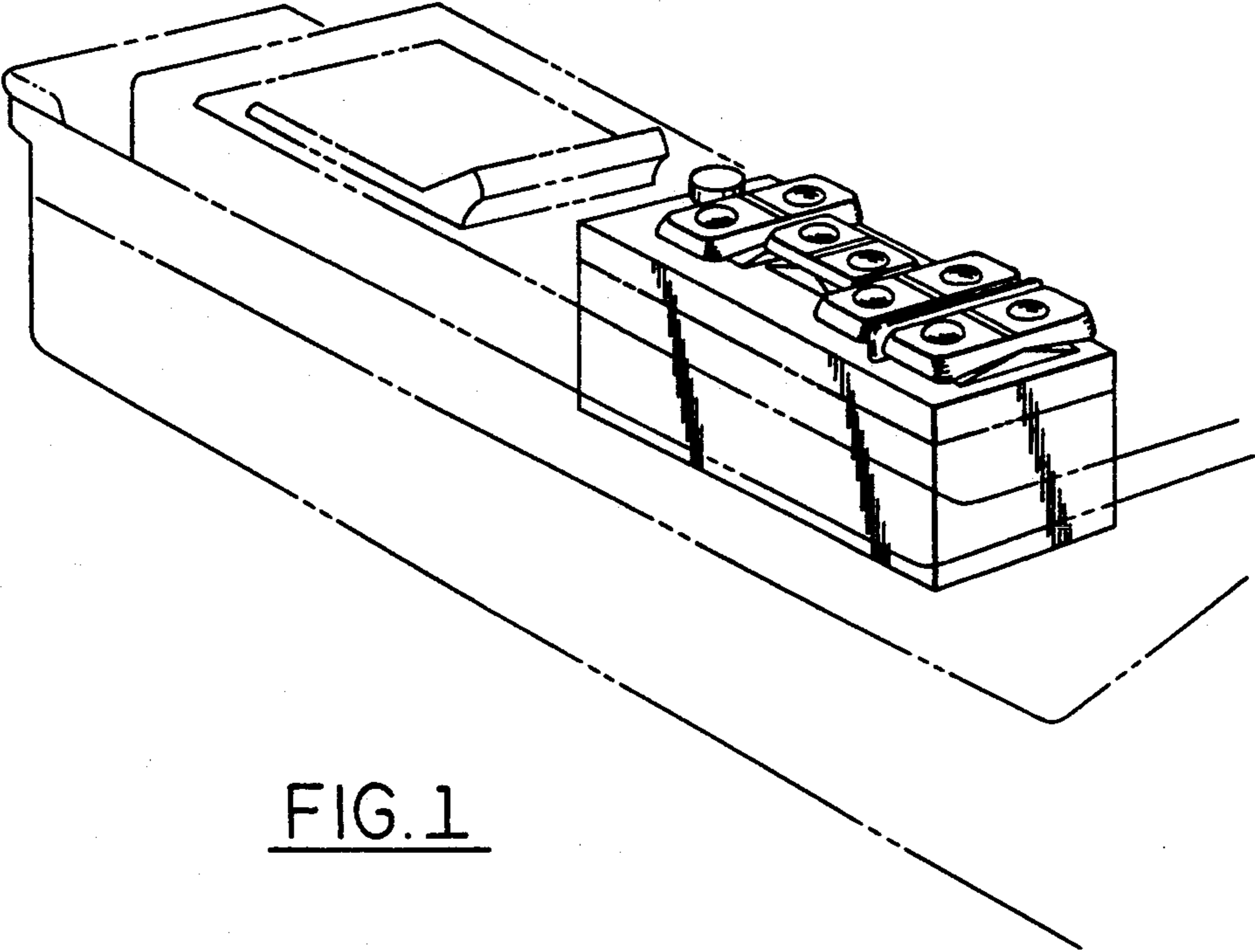

FIG. 1

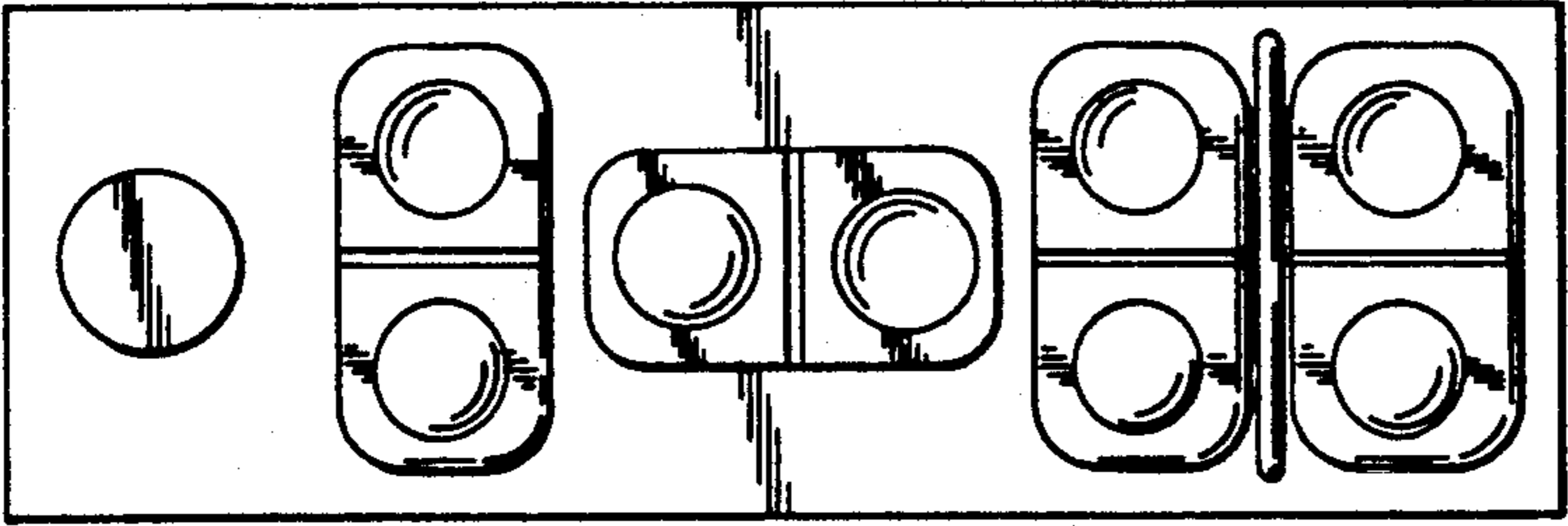

FIG. 2

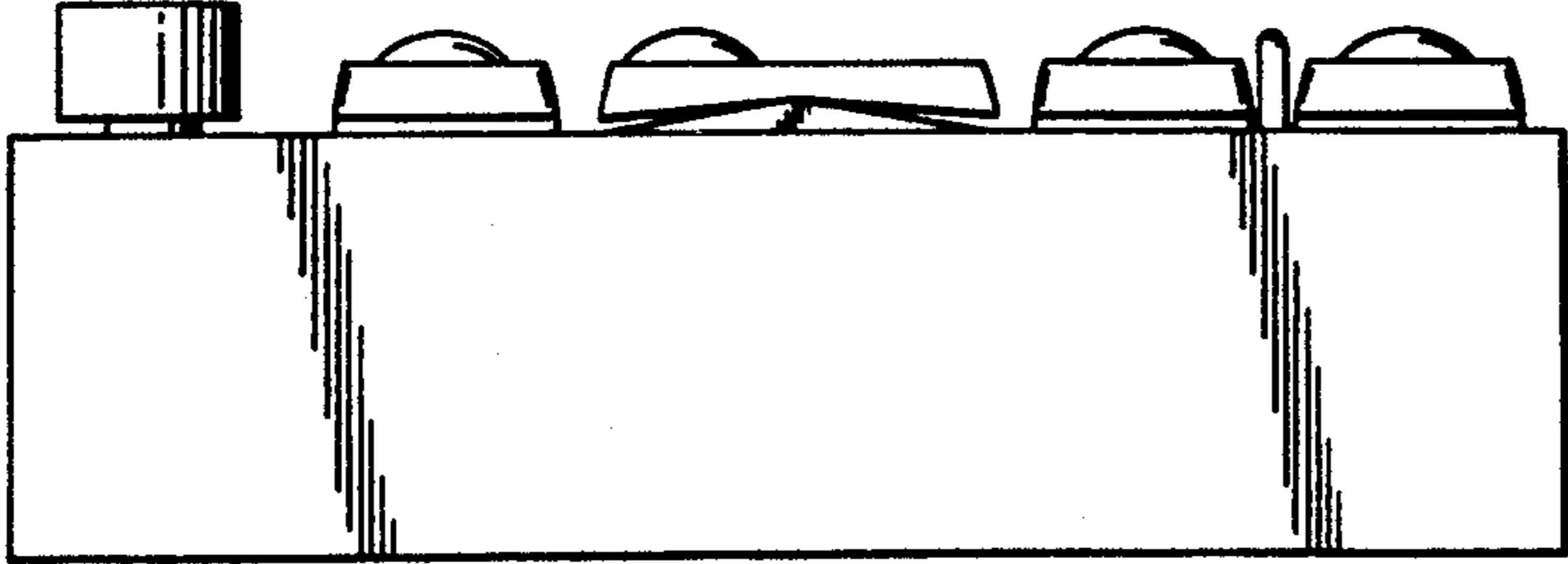

FIG. 3

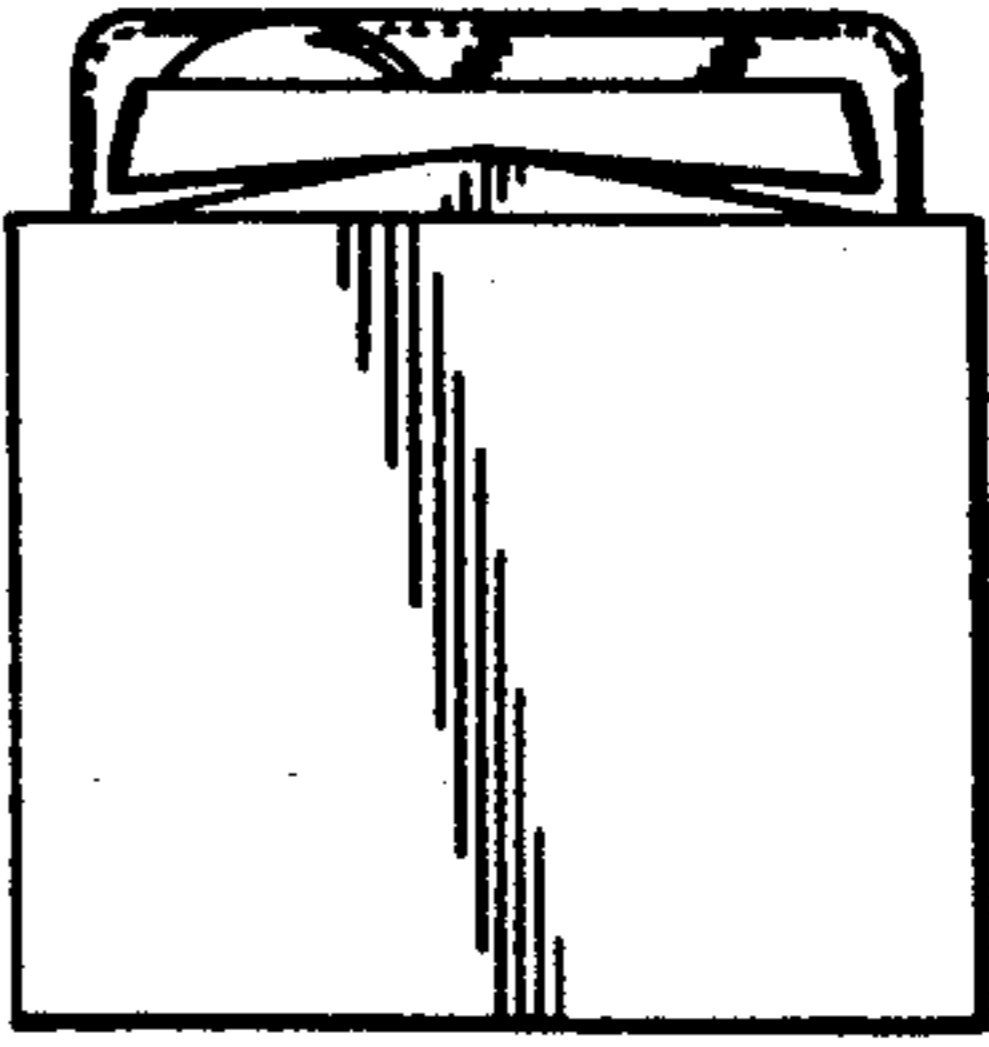

FIG. 4