



US00D338138S

United States Patent [19]

[11] Patent Number: **Des. 338,138**

Miyajima

[45] Date of Patent: **** Aug. 10, 1993**

[54] CONTAINER HOLDER FOR AUTOMOBILES

Attorney, Agent, or Firm—Koda and Androlia

[75] Inventor: Toshio Miyajima, Tokyo, Japan

[57] CLAIM

[73] Assignee: Seiko Sangyo Co., Ltd., Tokyo, Japan

The ornamental design for a container holder for automobiles, as shown and described.

[**] Term: 14 Years

DESCRIPTION

[21] Appl. No.: 753,624

FIG. 1 is a perspective view taken from the top, front and left side of the container holder for automobiles showing my new design;

[22] Filed: Aug. 30, 1991

[52] U.S. Cl. D7/620; D3/40

FIG. 2 is a perspective view taken from the top, rear and right side thereof;

[58] Field of Search D3/40; D7/620;
248/311.2; 224/273-275, 42.42, 42.11; 108/44,
46

FIG. 3 is a left side elevational view thereof; the right side view being a mirror image;

[56] References Cited

U.S. PATENT DOCUMENTS

- D. 279,837 7/1985 Tanaka D3/40
- D. 280,263 8/1985 Hoyer D3/40
- D. 331,862 12/1992 Brown D7/620
- 4,828,211 5/1989 McConnell et al. 248/311.2

FIG. 4 is a front elevational view thereof;

FIG. 5 is a rear elevational view thereof;

FIG. 6 is a top plan view thereof;

FIG. 7 is a bottom plan view thereof; and,

FIG. 8 is a perspective view taken from the top, front and left side of the container holder for automobiles with the front retaining cover, rear retaining member and angle adjustment means opened.

Primary Examiner—Louis S. Zarfes

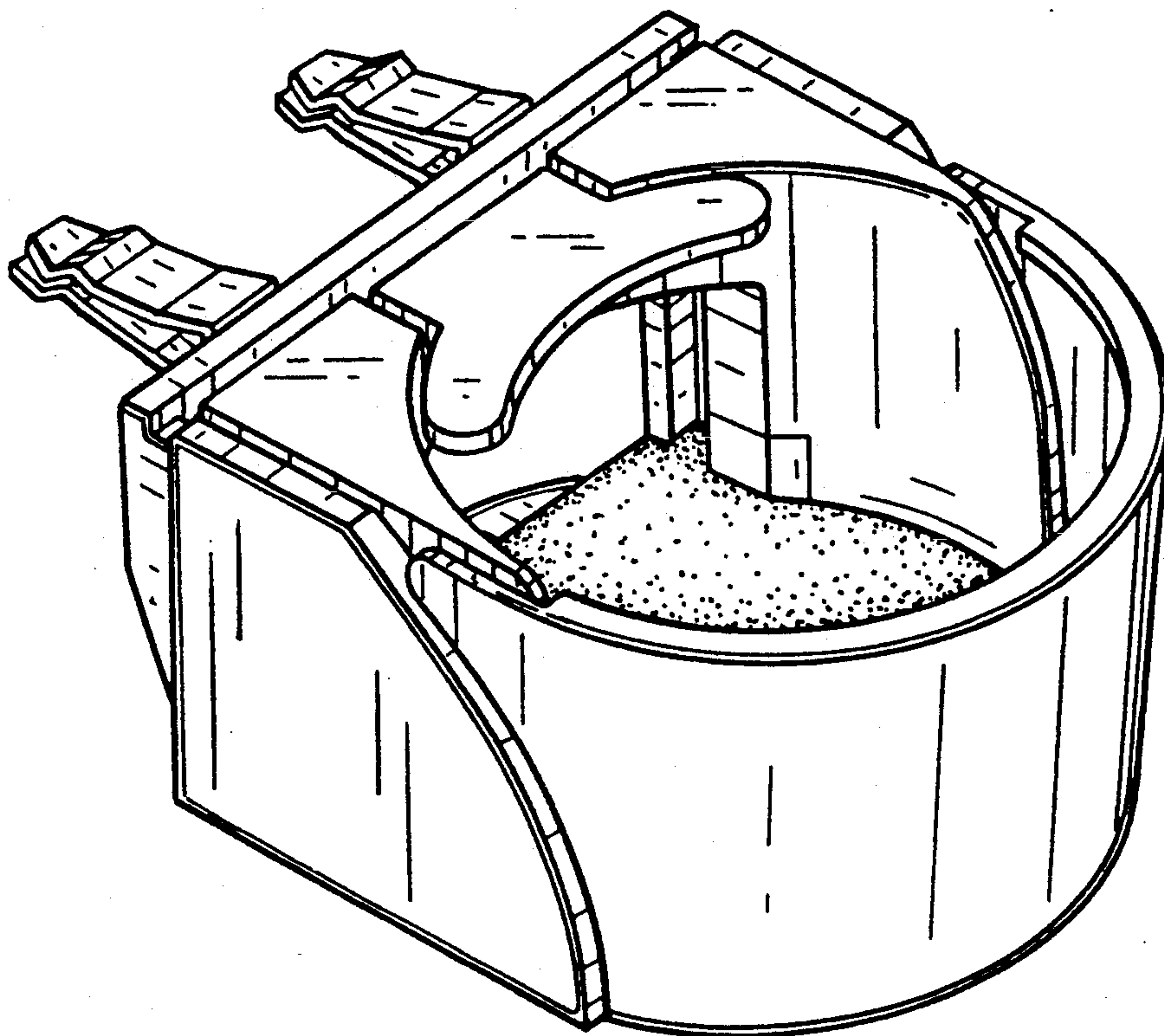

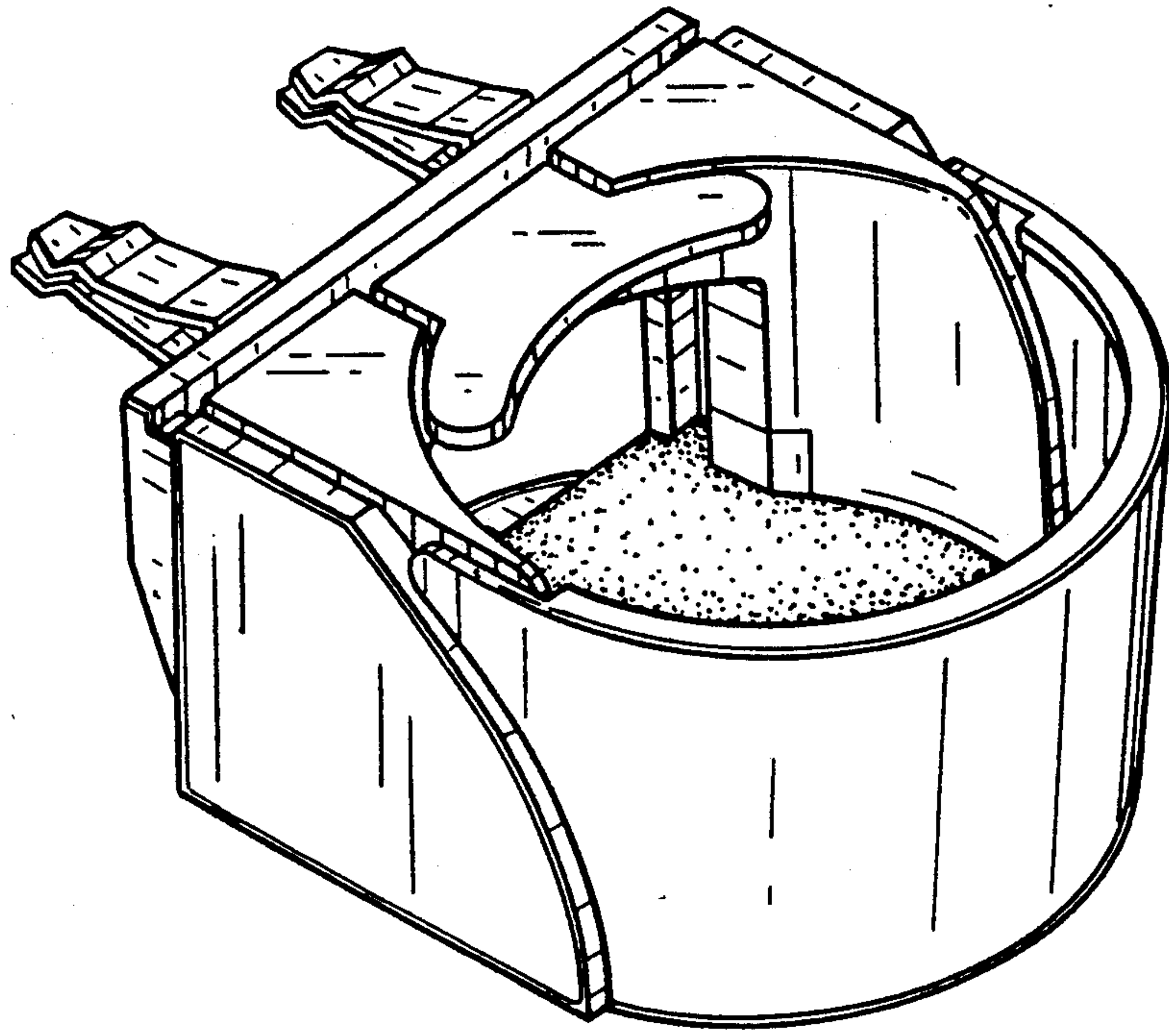

FIG. 1

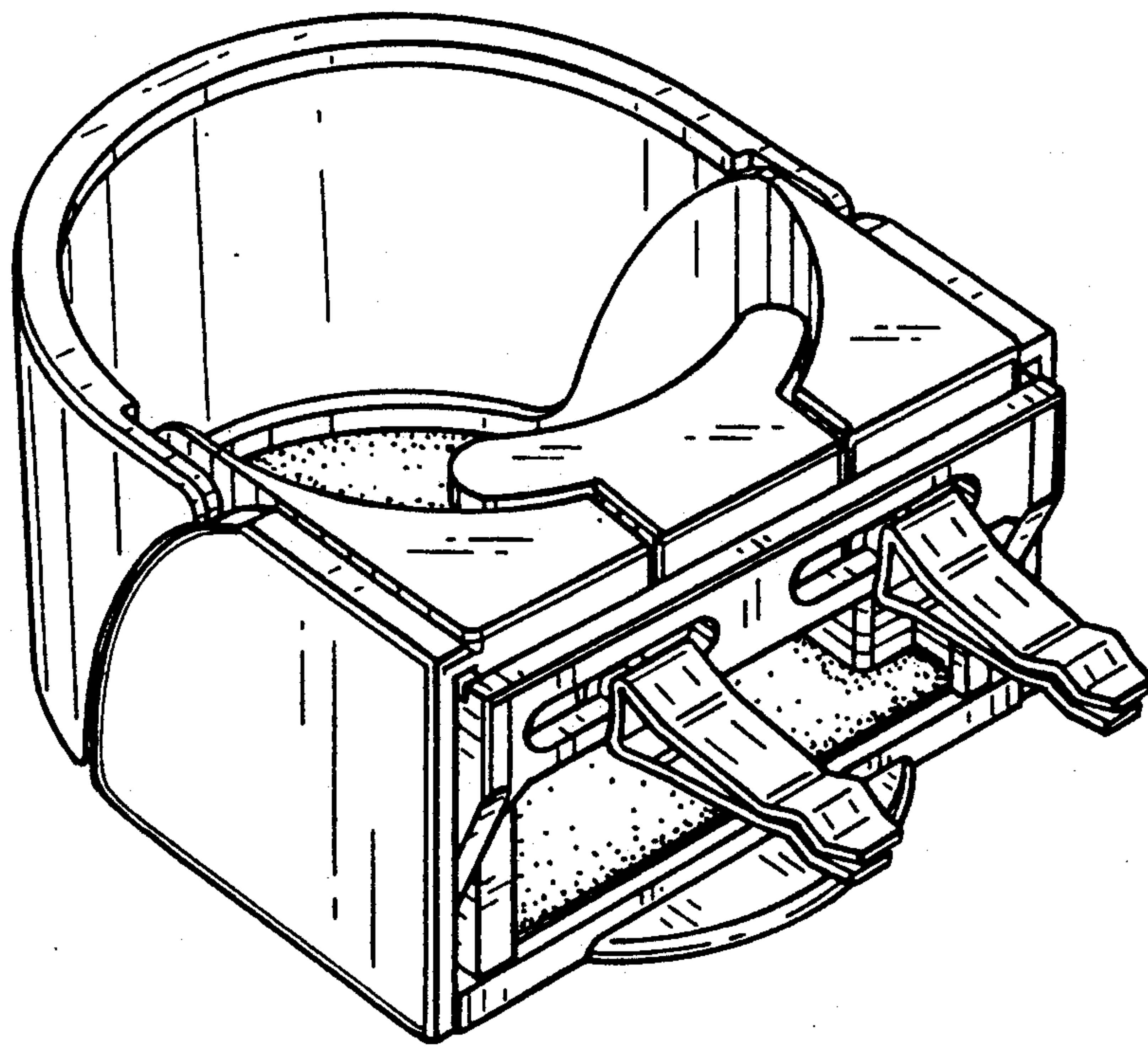

FIG. 2

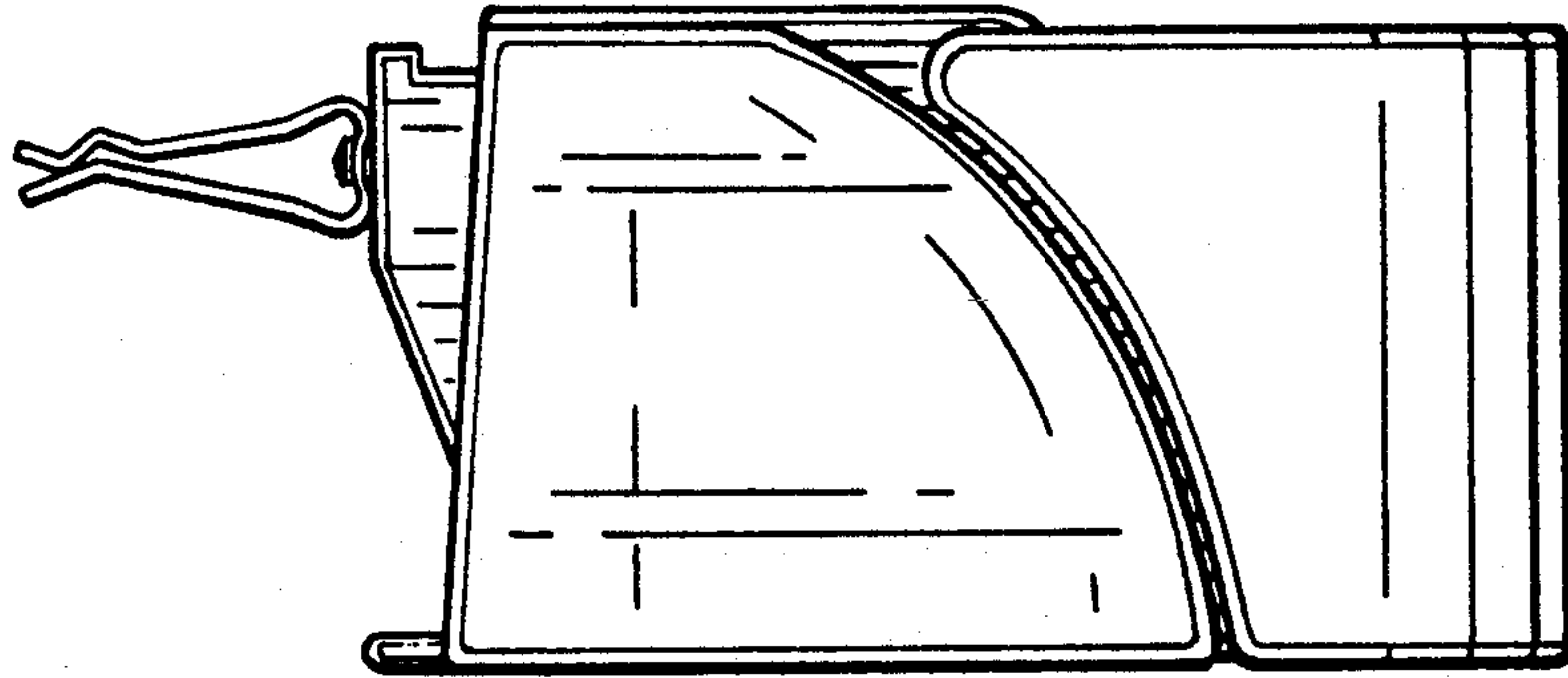

FIG. 3

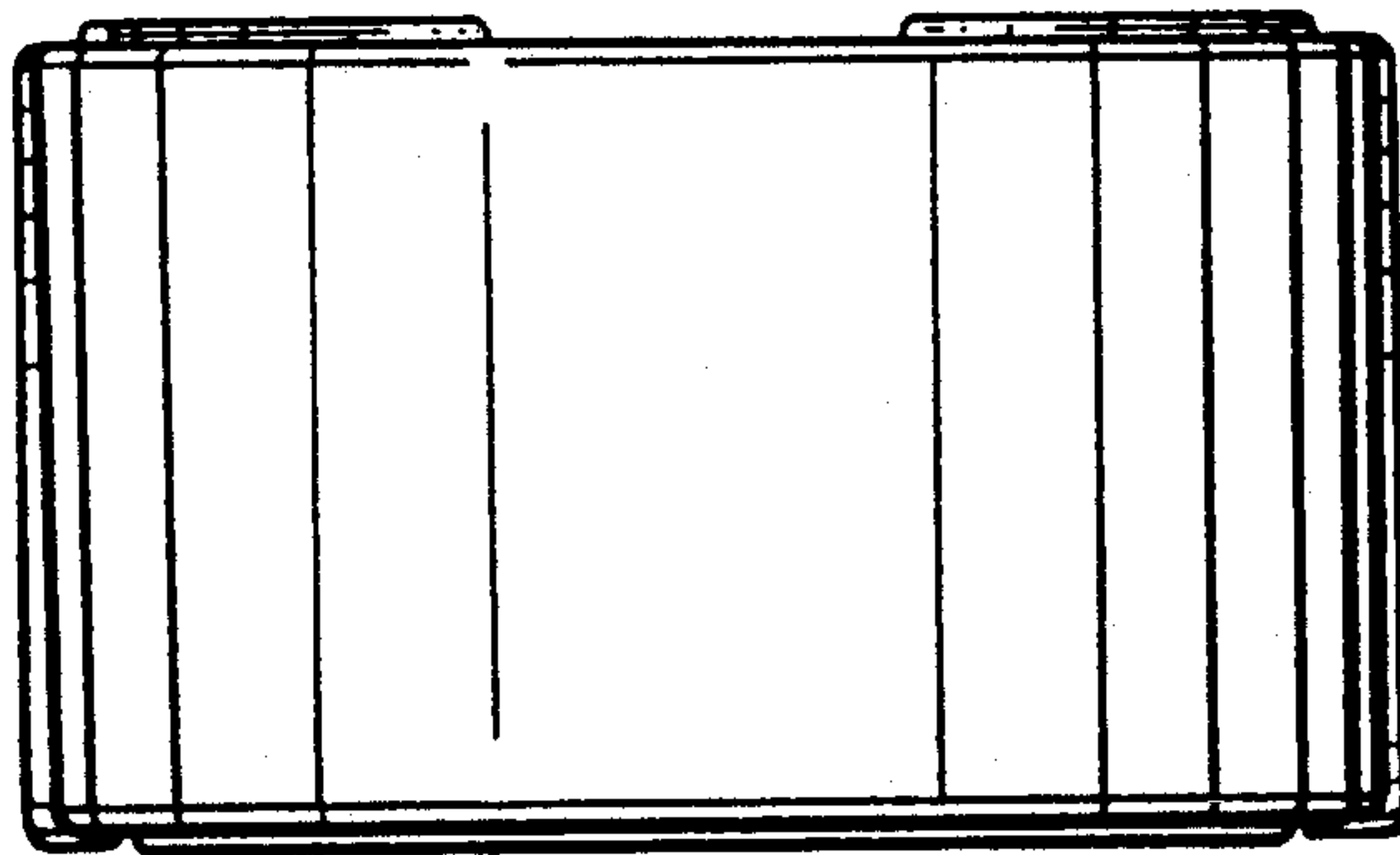

FIG. 4

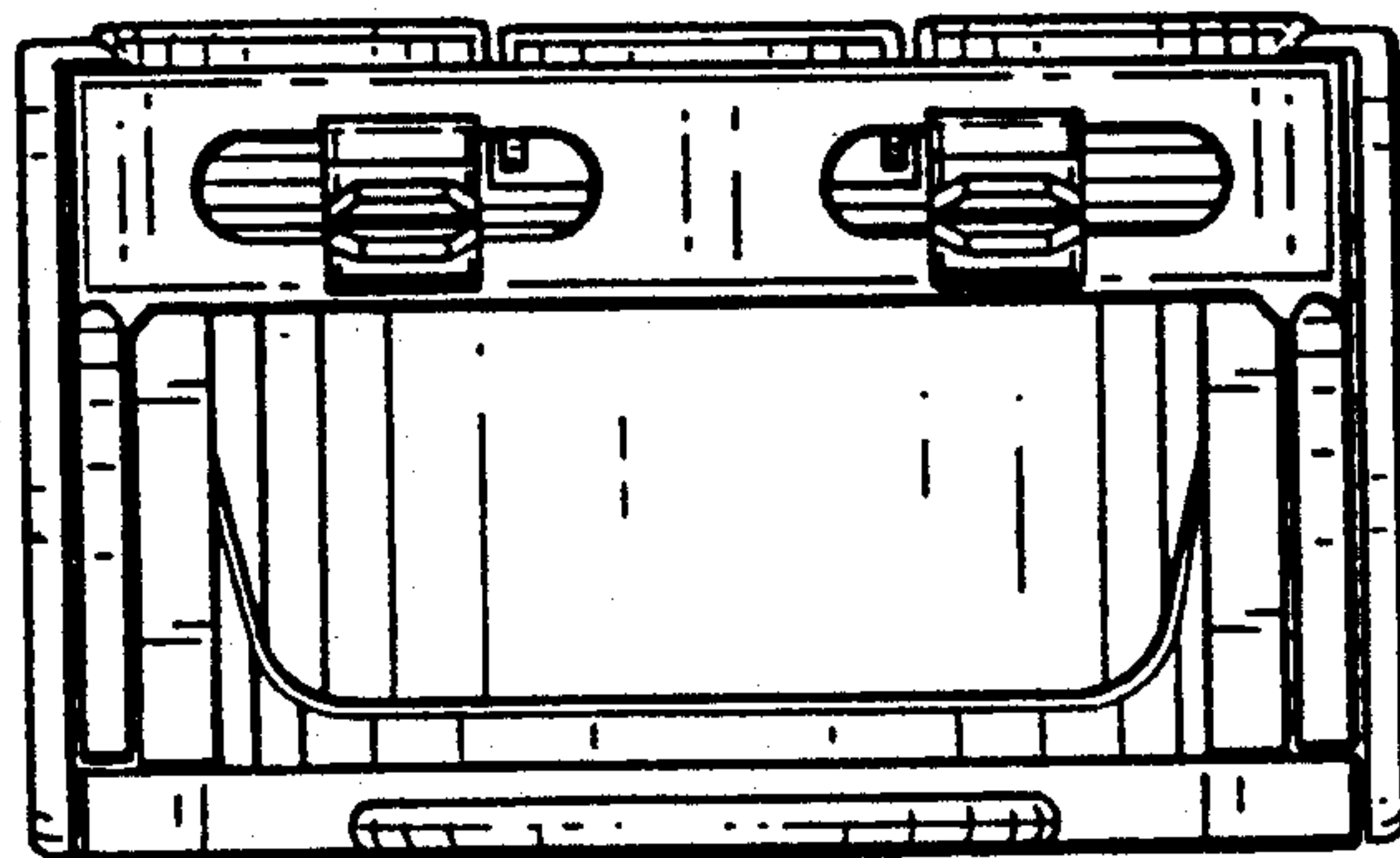

FIG. 5

FIG. 6

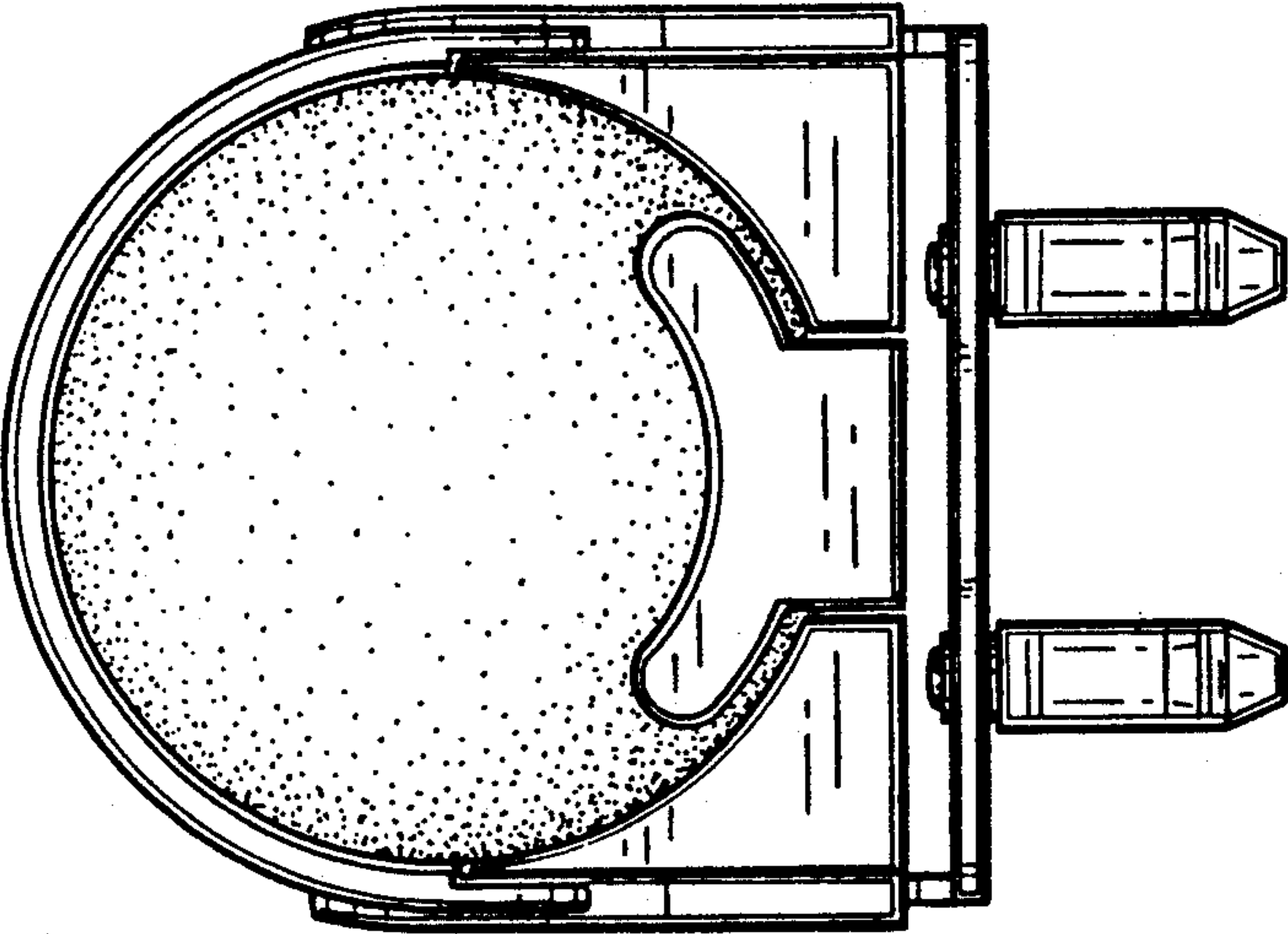

FIG. 7

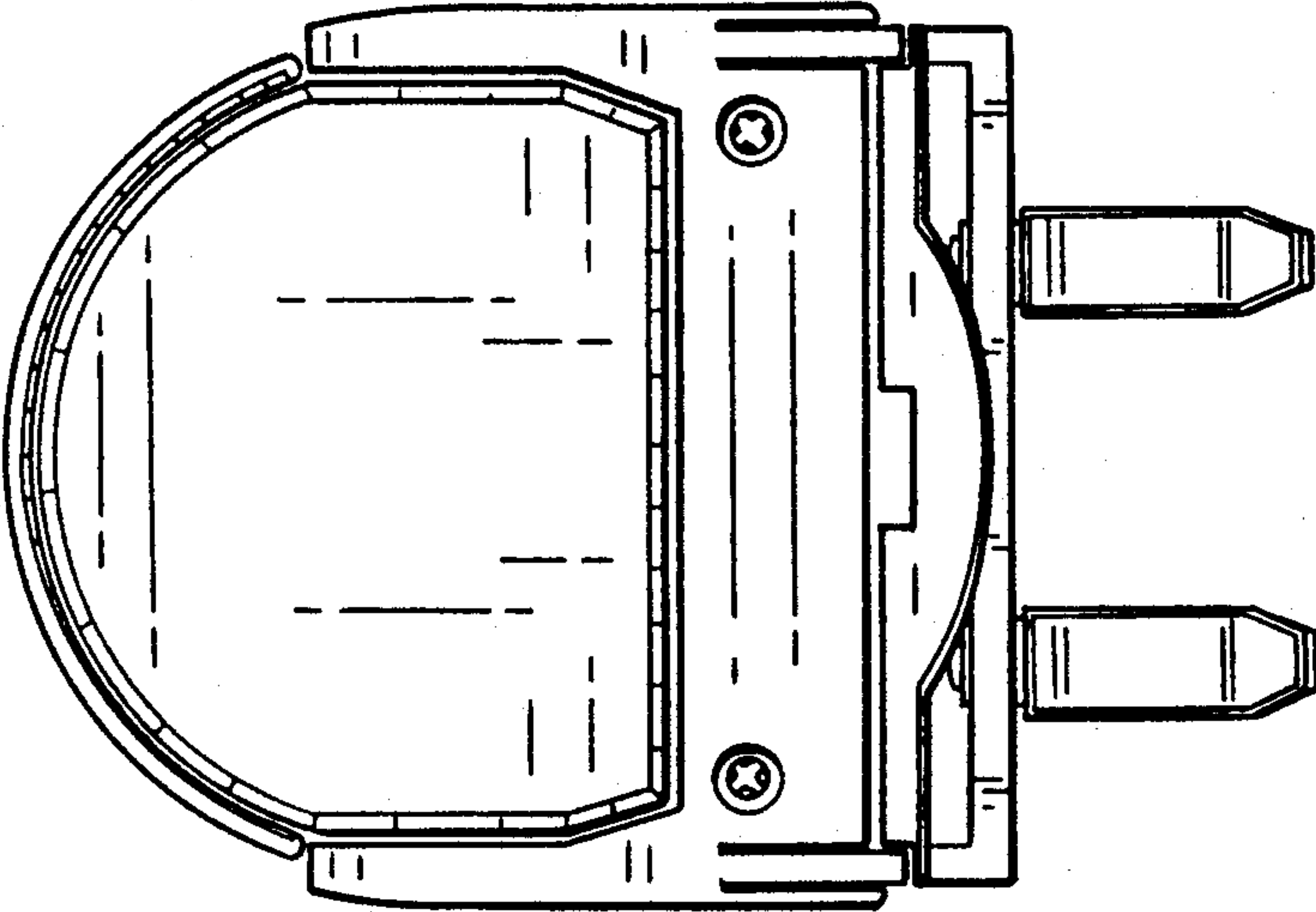

FIG. 8

