



US00D338020S

**United States Patent** [19]  
**Taft**

[11] **Patent Number: Des. 338,020**

[45] **Date of Patent: \*\* Aug. 3, 1993**

[54] **TRACK LINK**

[75] **Inventor: Morris E. Taft, Metamora, Ill.**

[73] **Assignee: Caterpillar, Inc., Peoria, Ill.**

[\*\*] **Term: 14 Years**

[21] **Appl. No.: 797,848**

[22] **Filed: Nov. 26, 1991**

[52] **U.S. Cl. .... D15/28**

[58] **Field of Search ..... D15/28; 305/35 R, 39, 305/54, 58 R**

**FOREIGN PATENT DOCUMENTS**

1229870 12/1966 Fed. Rep. of Germany .... 305/35 R

*Primary Examiner*—B. J. Bullock

*Assistant Examiner*—Sandra Morris

*Attorney, Agent, or Firm*—O. Gordon Pence

[57] **CLAIM**

The ornamental design for a track link, as shown and described.

**DESCRIPTION**

FIG. 1 is a right side view of a track link, showing my new design;

FIG. 2 is a left side view thereof;

FIG. 3 is a top view thereof;

FIG. 4 is a bottom view thereof;

FIG. 5 is a front view thereof;

FIG. 6 is a rear view thereof;

FIG. 7 is an isometric view of the right side and top thereof; and,

FIG. 8 is an isometric view of the left side and bottom thereof.

[56] **References Cited**

**U.S. PATENT DOCUMENTS**

D. 260,899	9/1981	Joseph et al. ....	D15/28
4,083,611	4/1978	Schaffner et al. ....	305/54
4,121,875	10/1978	Stedman .....	305/39
4,141,602	2/1979	Stedman .....	305/54
4,222,616	9/1980	Brewer .....	305/54
4,423,910	1/1984	Narang .....	305/39
4,449,357	5/1984	Balitch .....	59/30
4,553,791	11/1985	Blair .....	305/39
4,880,283	11/1989	Savage et al. ....	305/35 R

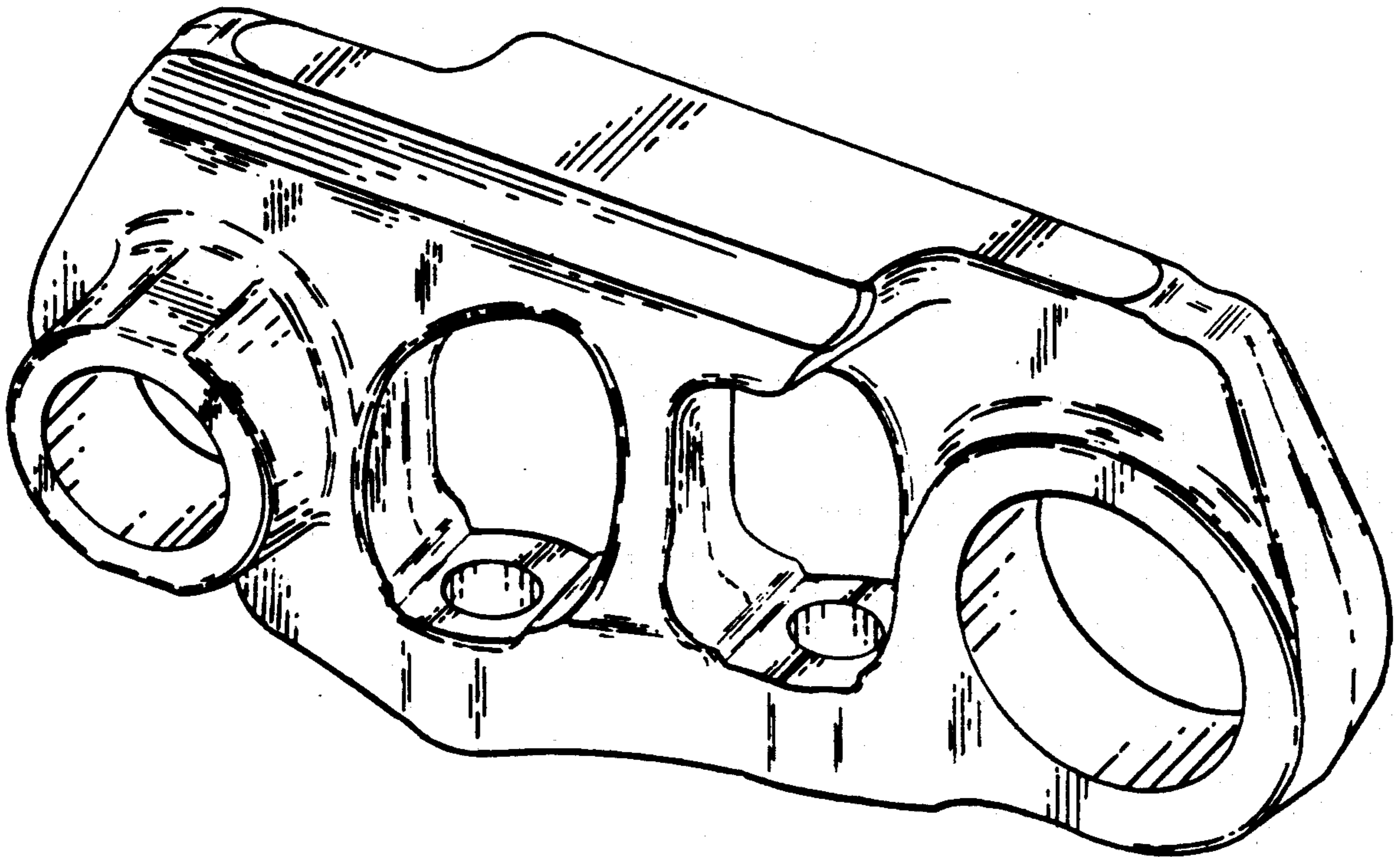

FIG. 1.

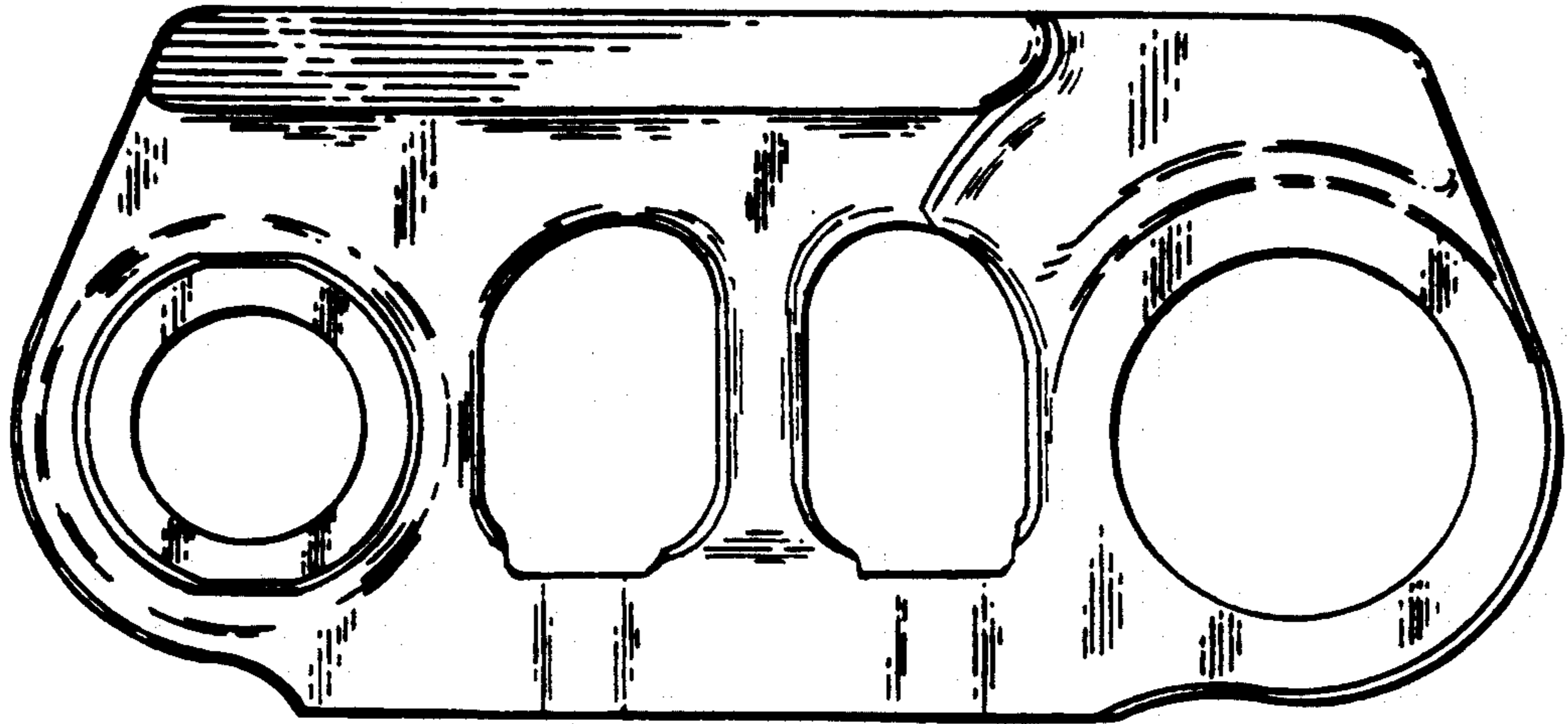

FIG. 2.

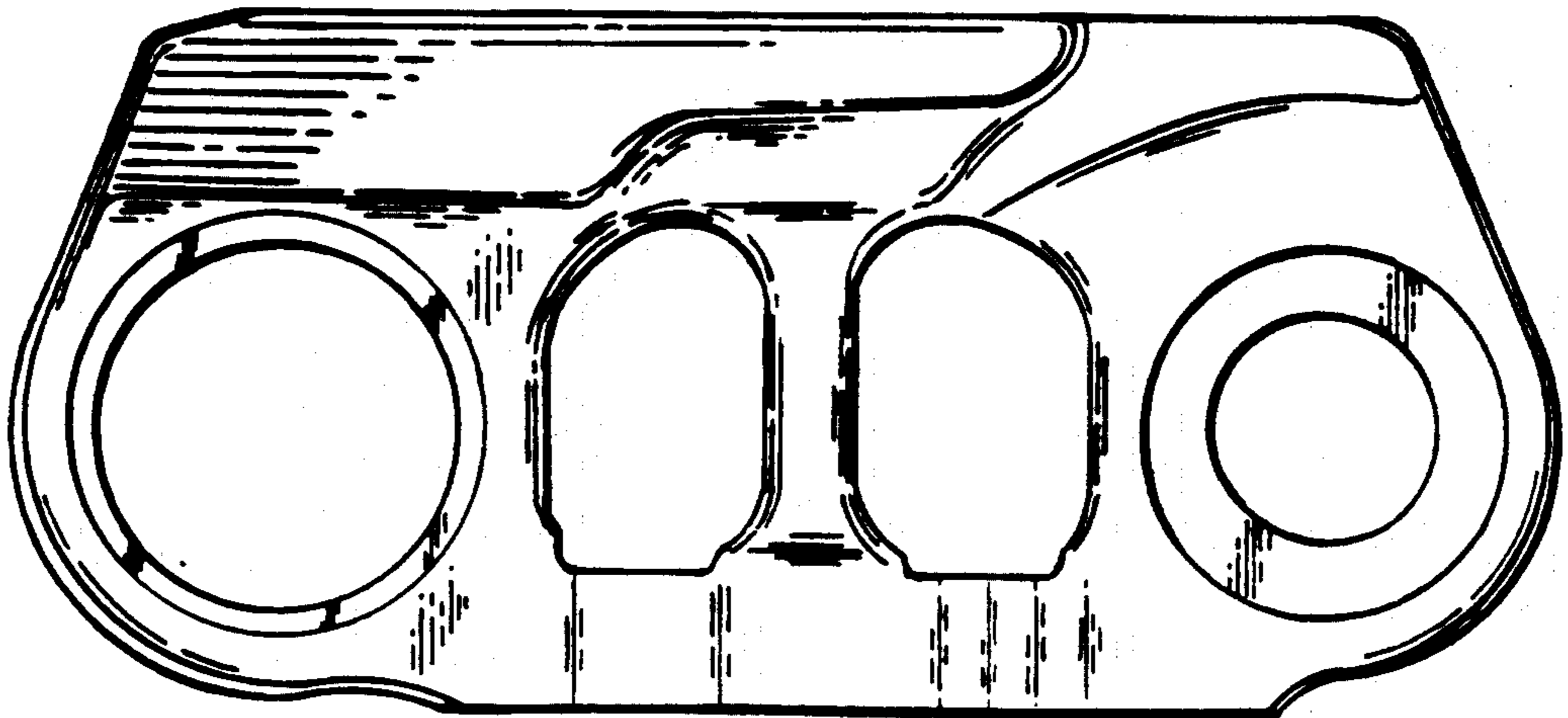

FIG. 3.

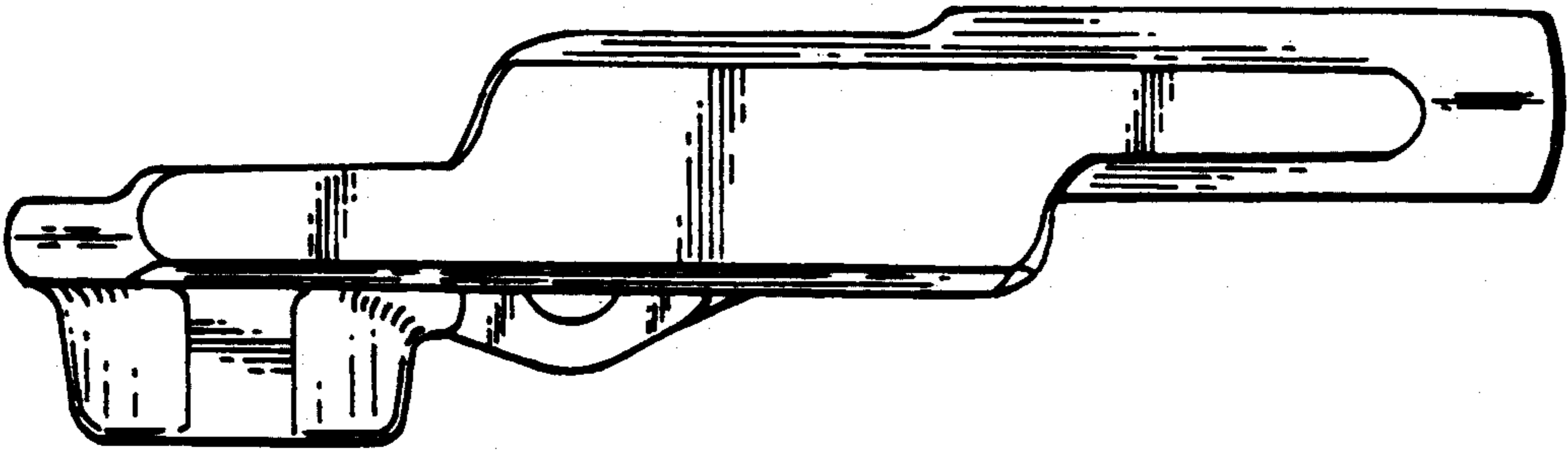

FIG. 4.

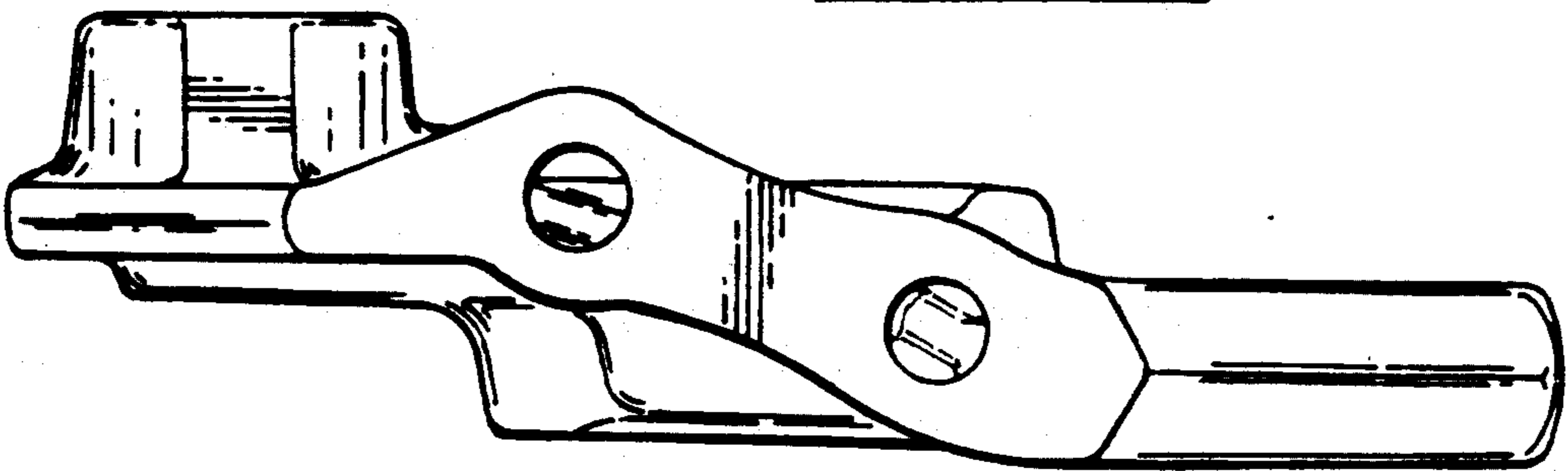

FIG. 5.

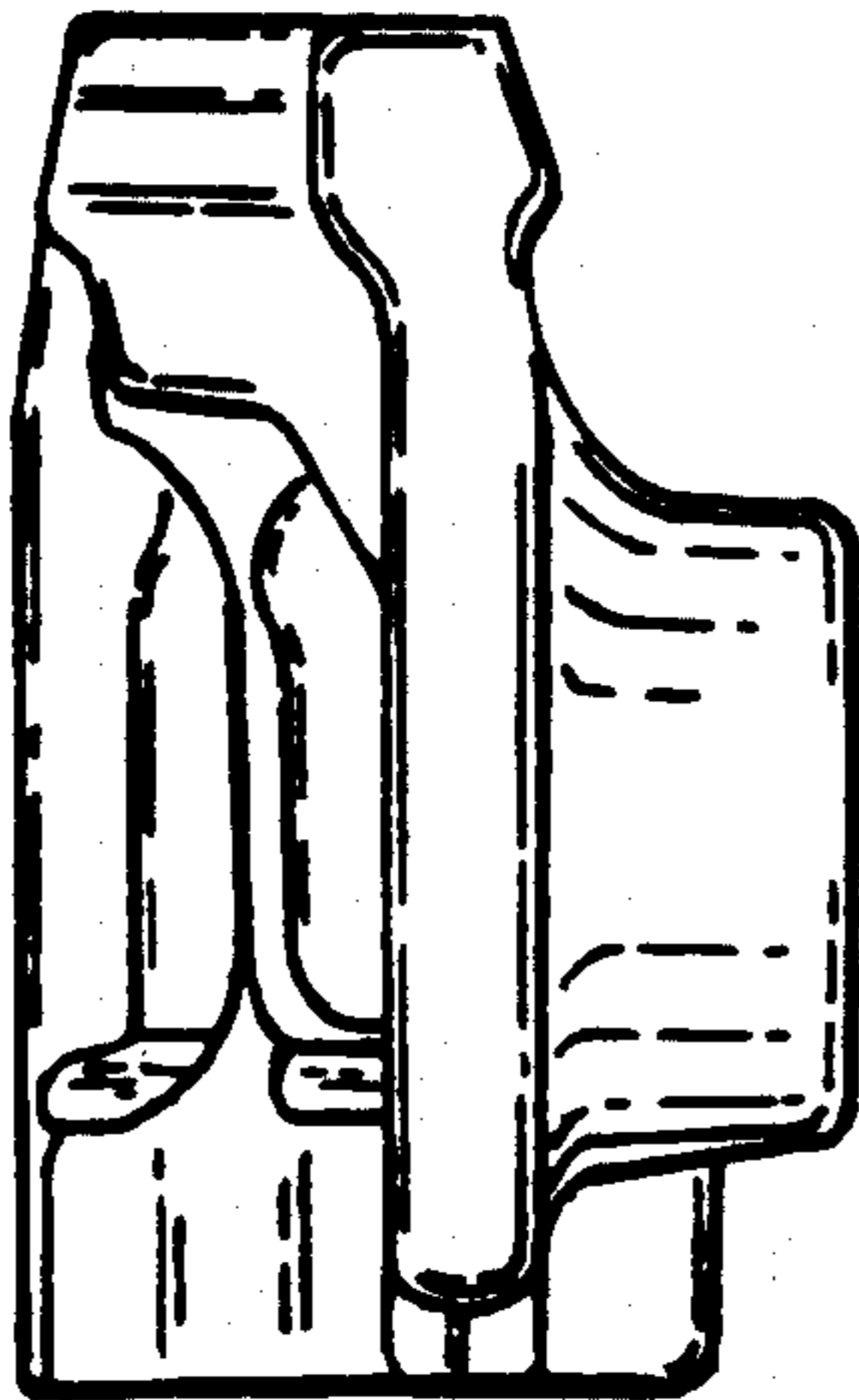

FIG. 6.

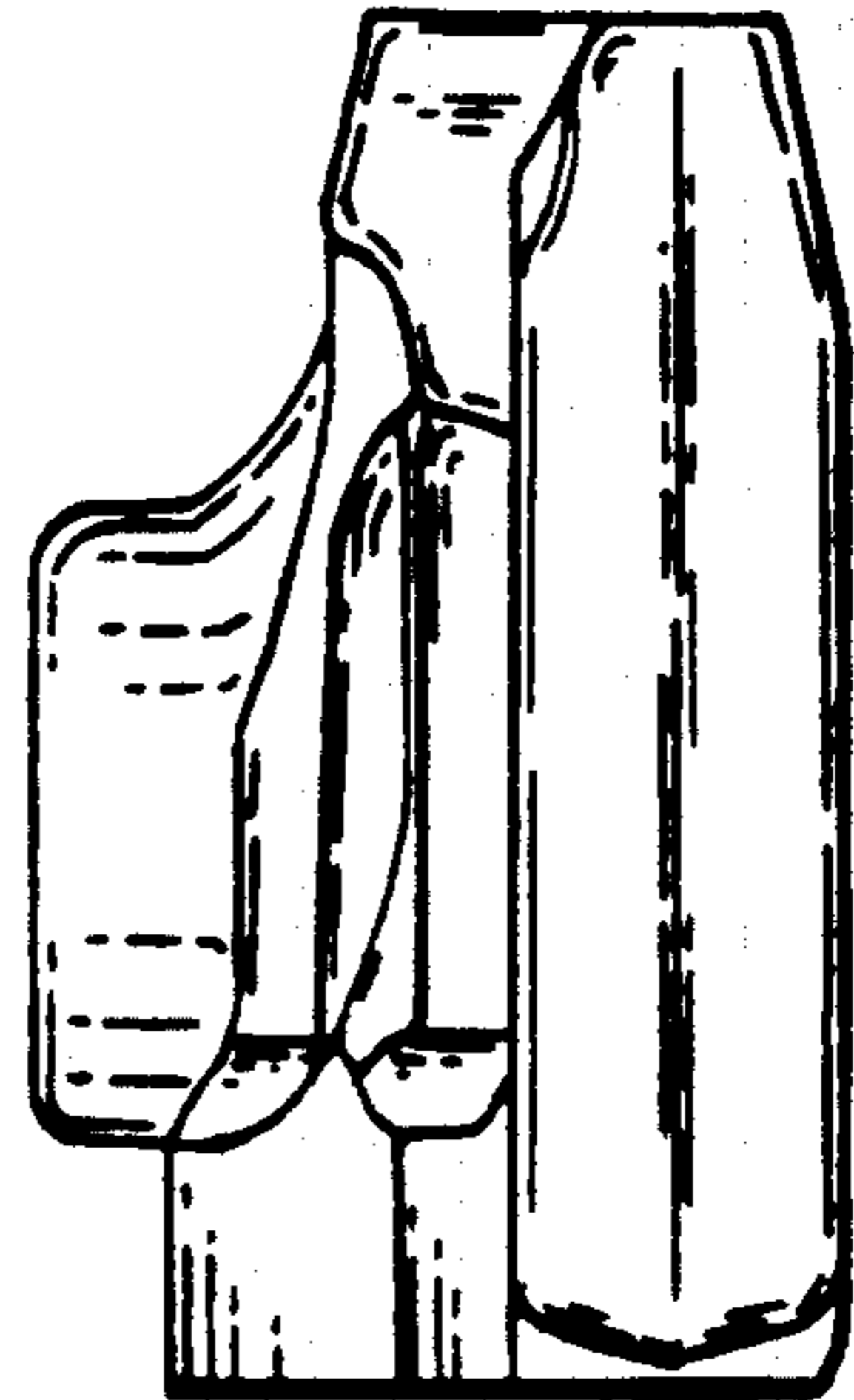

FIG. 7.

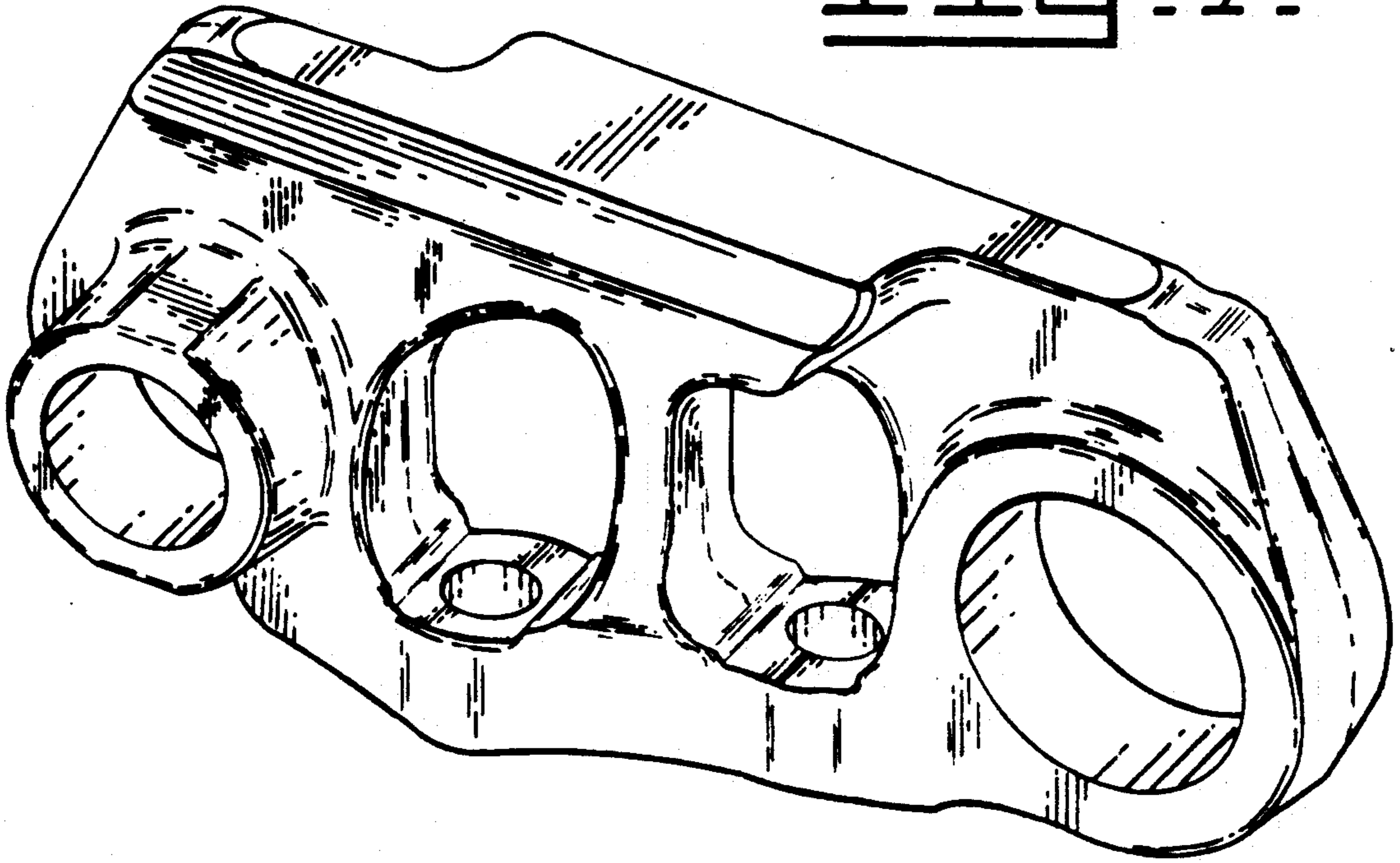

FIG. 8.

