



US00D337968S

United States Patent [19] Kimball

[11] Patent Number: Des. 337,968

[45] Date of Patent: ** Aug. 3, 1993

[54] OFF-ROAD VEHICLE

[76] Inventor: James F. Kimball, 83617 Rattlesnake Rd., Dexter, Oreg. 97431

[**] Term: 14 Years

[21] Appl. No.: 684,361

[22] Filed: Apr. 12, 1991

[52] U.S. Cl. D12/1

[58] Field of Search D12/1, 131, 3, 133, D12/87; 180/6.2, 24.08, DIG. 907, DIG. 908, 233, 311, 315, 312; 280/282, 28.5, 756, 797

[56] References Cited

U.S. PATENT DOCUMENTS

- D. 235,984 7/1975 Crovatto et al. D12/1
- D. 250,522 12/1978 Miner et al. D12/1
- D. 294,476 3/1988 Michel et al. D12/131

- 4,924,959 4/1990 Handu et al. 280/756
- 4,946,193 8/1990 Oka 180/DIG. 908

Primary Examiner—Wallace R. Burke
Assistant Examiner—Melody Brown
Attorney, Agent, or Firm—James D. Givnan, Jr.

[57] CLAIM

The ornamental design for an off-road vehicle, as shown and described.

DESCRIPTION

FIG. 1 is a side elevational view of an off-road vehicle showing my new design, the opposite side being a mirror image;
FIG. 2 is a top plan view thereof;
FIG. 3 is a front elevational view thereof;
FIG. 4 is a rear elevational view thereof; and,
FIG. 5 is a top perspective view thereof.

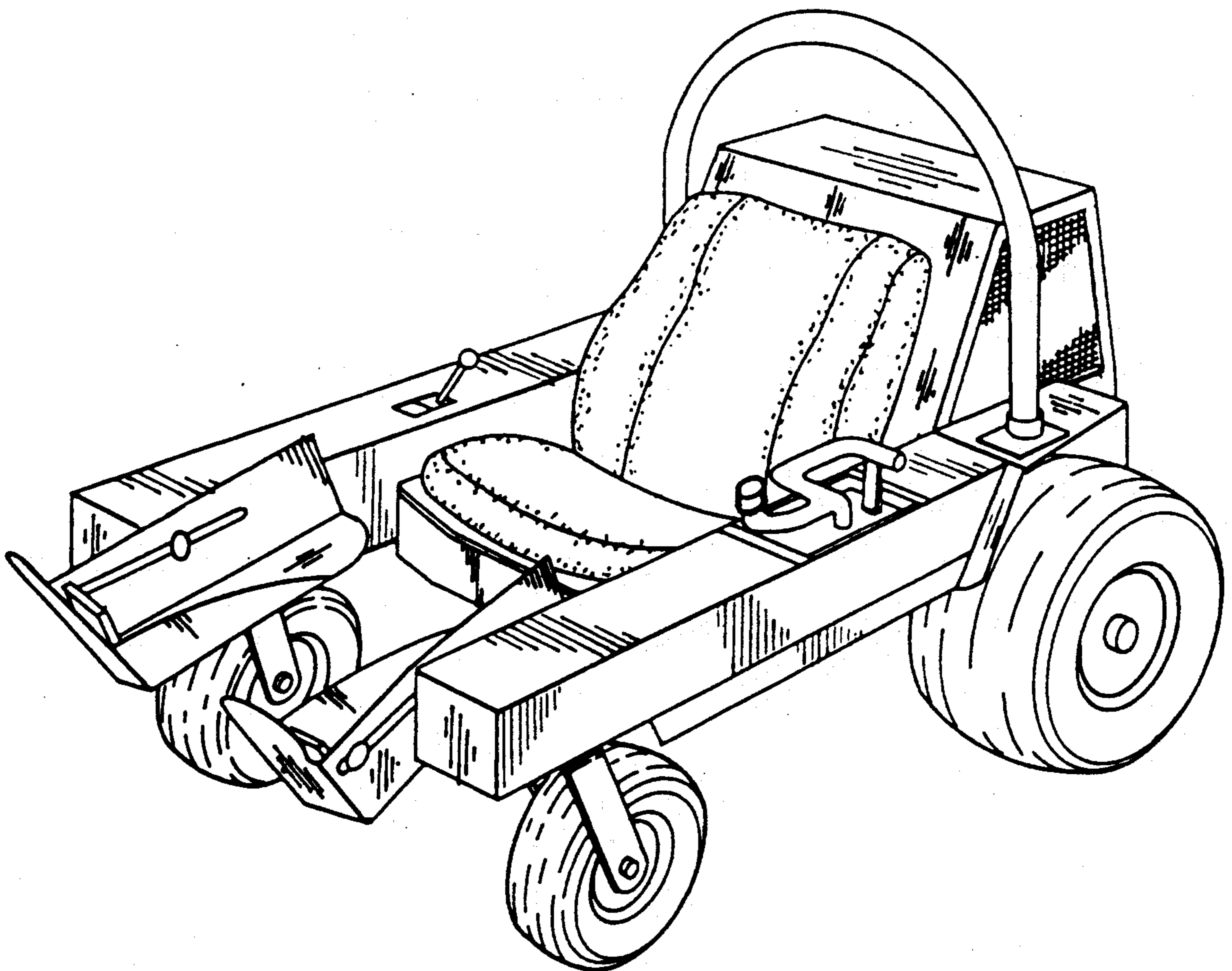

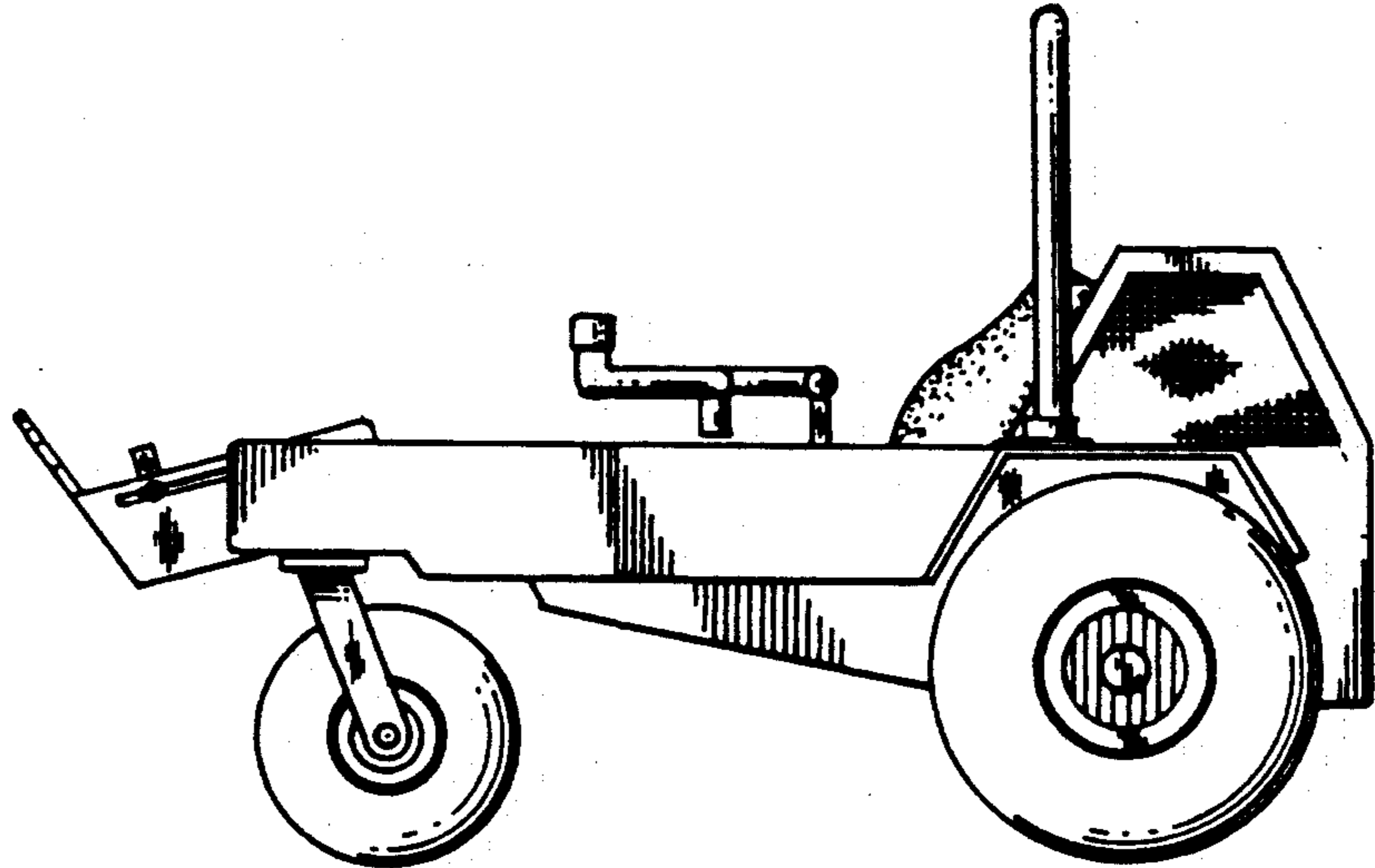

FIG. 1

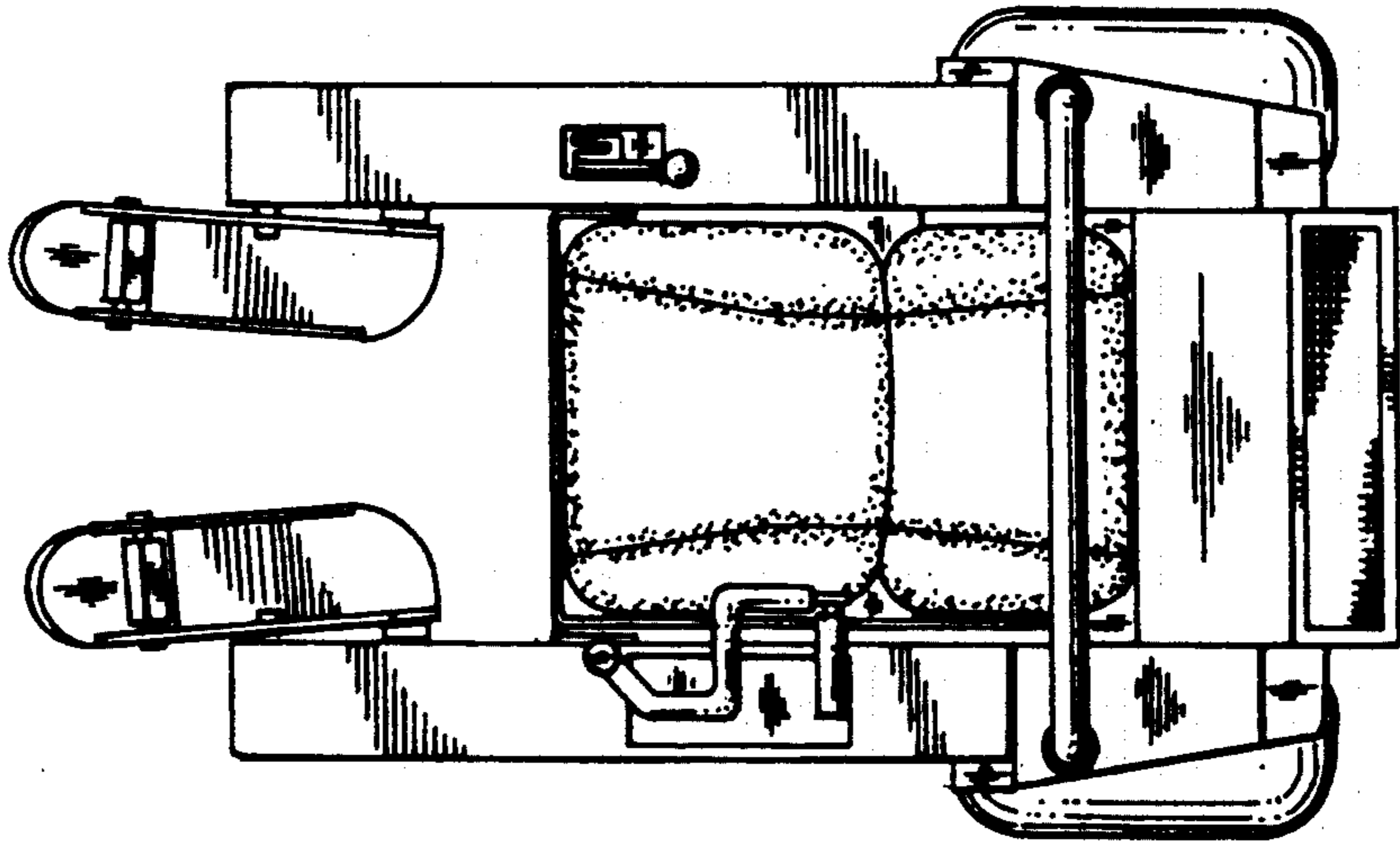

FIG. 2

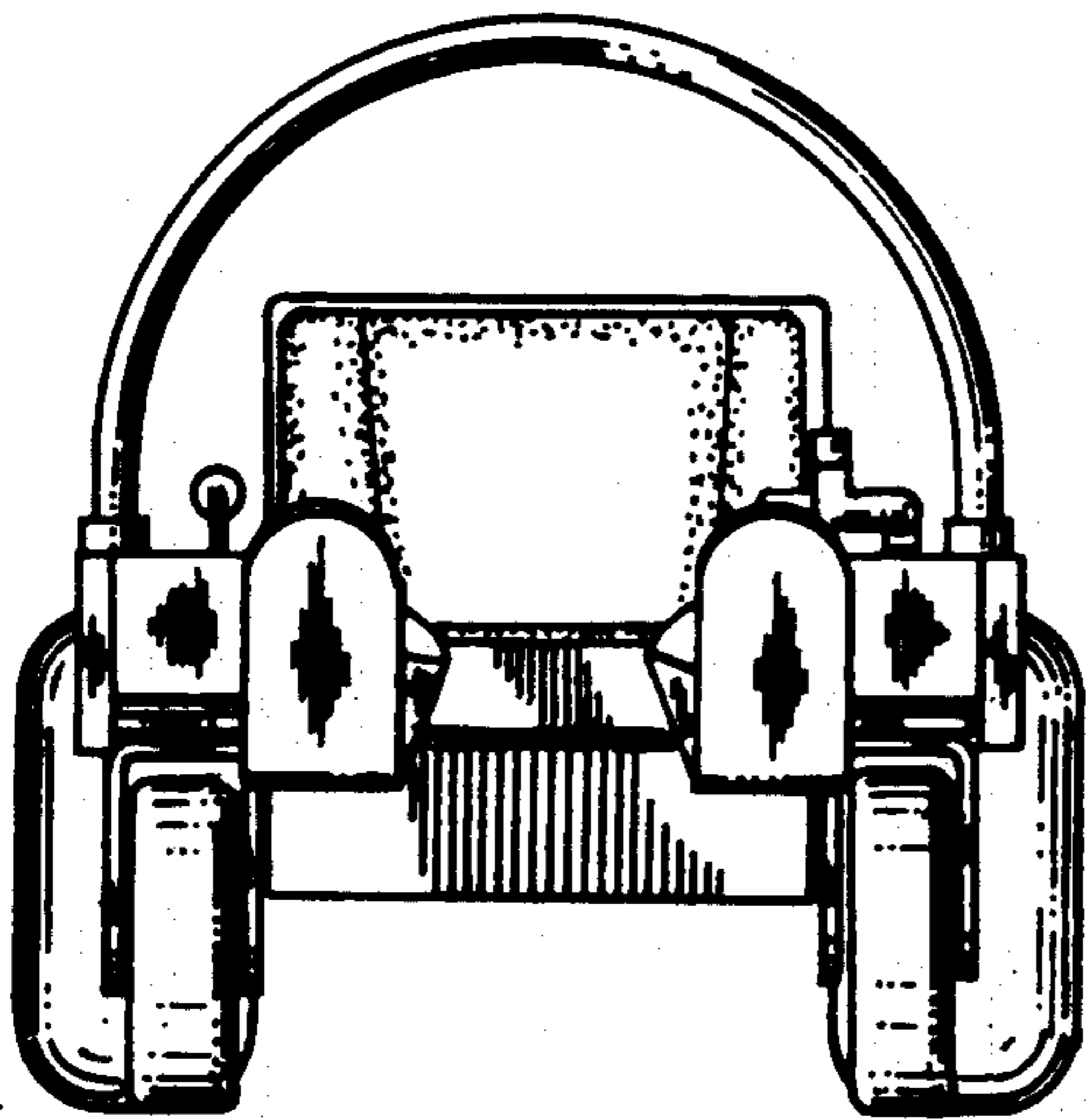

FIG. 3

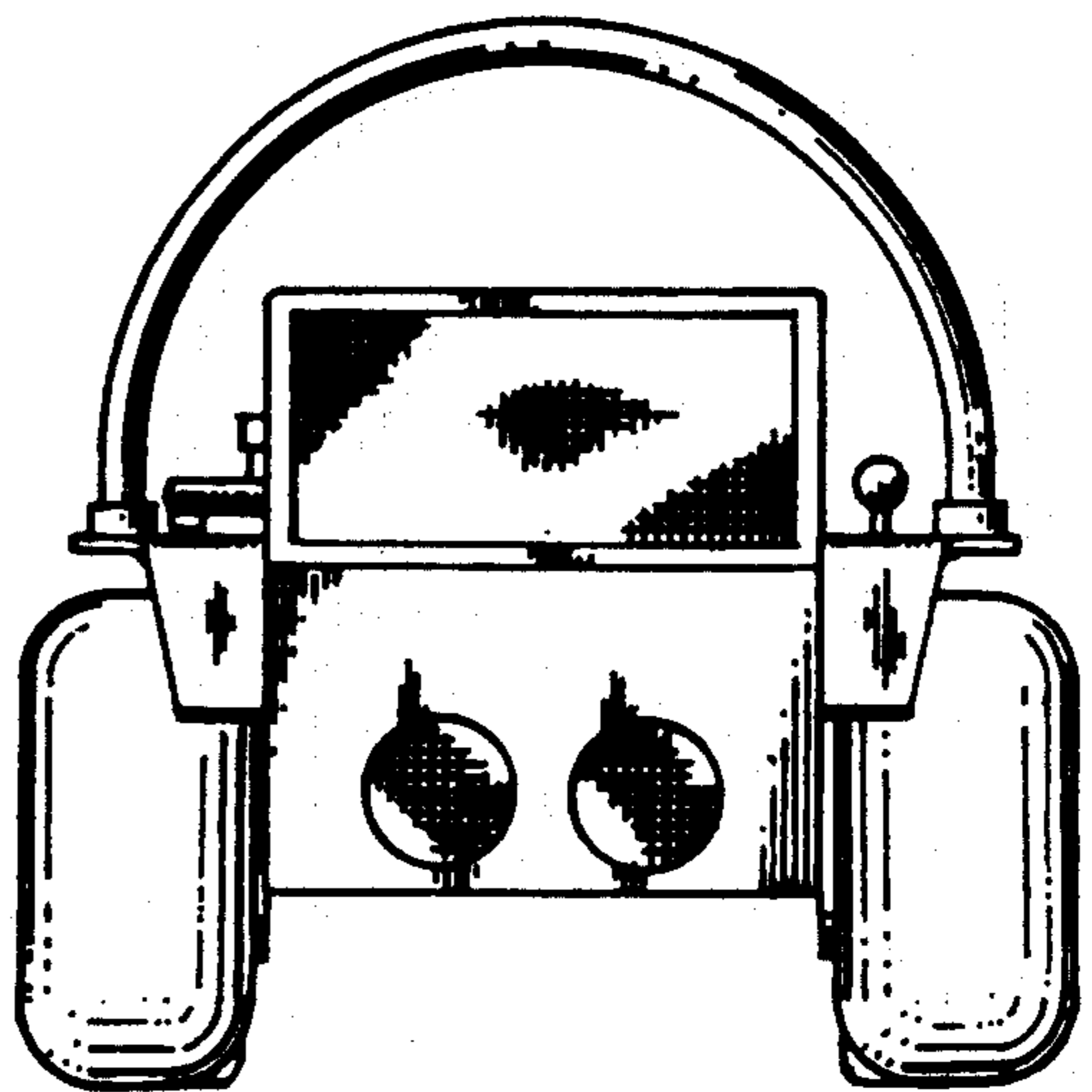

FIG. 4

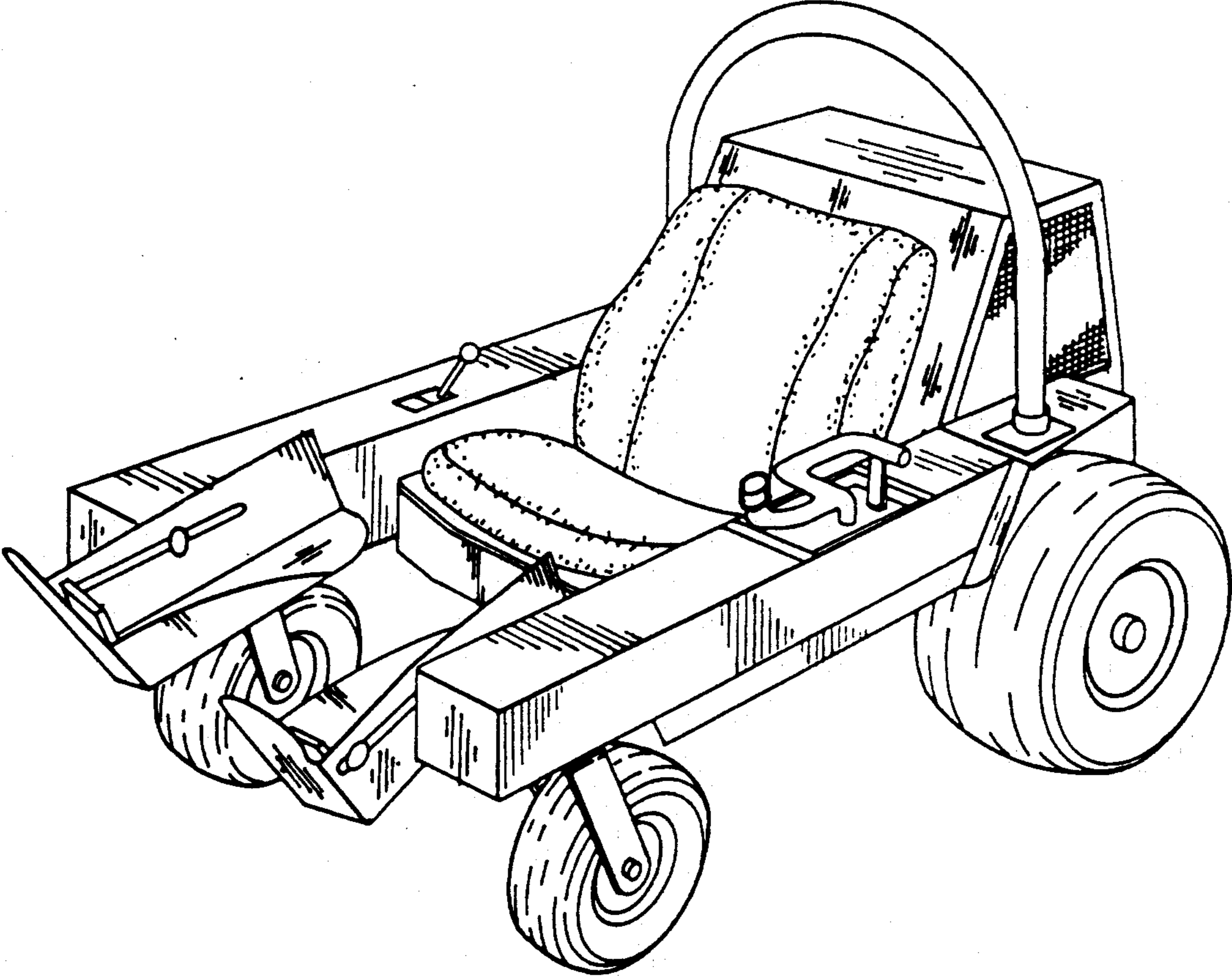

FIG. 5