



US00D337840S

United States Patent [19]

Ekeroth

[11] Patent Number: **Des. 337,840**

[45] Date of Patent: **** Jul. 27, 1993**

[54] **PORTABLE HAND LANTERN**

[76] Inventor: **Vagn Ekeroth, Box 144, S-134 00 Gustavsberg, Sweden**

[**] Term: **14 Years**

[21] Appl. No.: **530,938**

[22] Filed: **May 25, 1990**

[52] U.S. Cl. **D26/44**

[58] Field of Search **D26/37-50; 362/157, 158, 183-191, 194-205**

[56] **References Cited**

U.S. PATENT DOCUMENTS

- D. 276,375 11/1984 Fenne D26/44
- D. 284,106 6/1986 Drane D26/44
- D. 287,887 1/1987 Tsuyama D26/44 X
- 4,207,606 6/1980 Gulliksen et al. 362/183 X

- 4,345,304 8/1982 Penney et al. 362/183
- 4,654,764 3/1987 Hsiao 362/199

Primary Examiner—Susan J. Lucas
Attorney, Agent, or Firm—Sughrue, Mion, Zinn, Macpeak & Seas

[57] **CLAIM**

The ornamental design for a portable hand lantern, as shown and described.

DESCRIPTION

FIG. 1 is a front, left side perspective view of a portable hand lantern showing my new design;
FIG. 2 is a front, top and right side perspective view thereof;
FIG. 3 is a right side elevational view thereof;
FIG. 4 is a front elevational view thereof; and,
FIG. 5 is a rear, bottom and left side perspective view thereof.

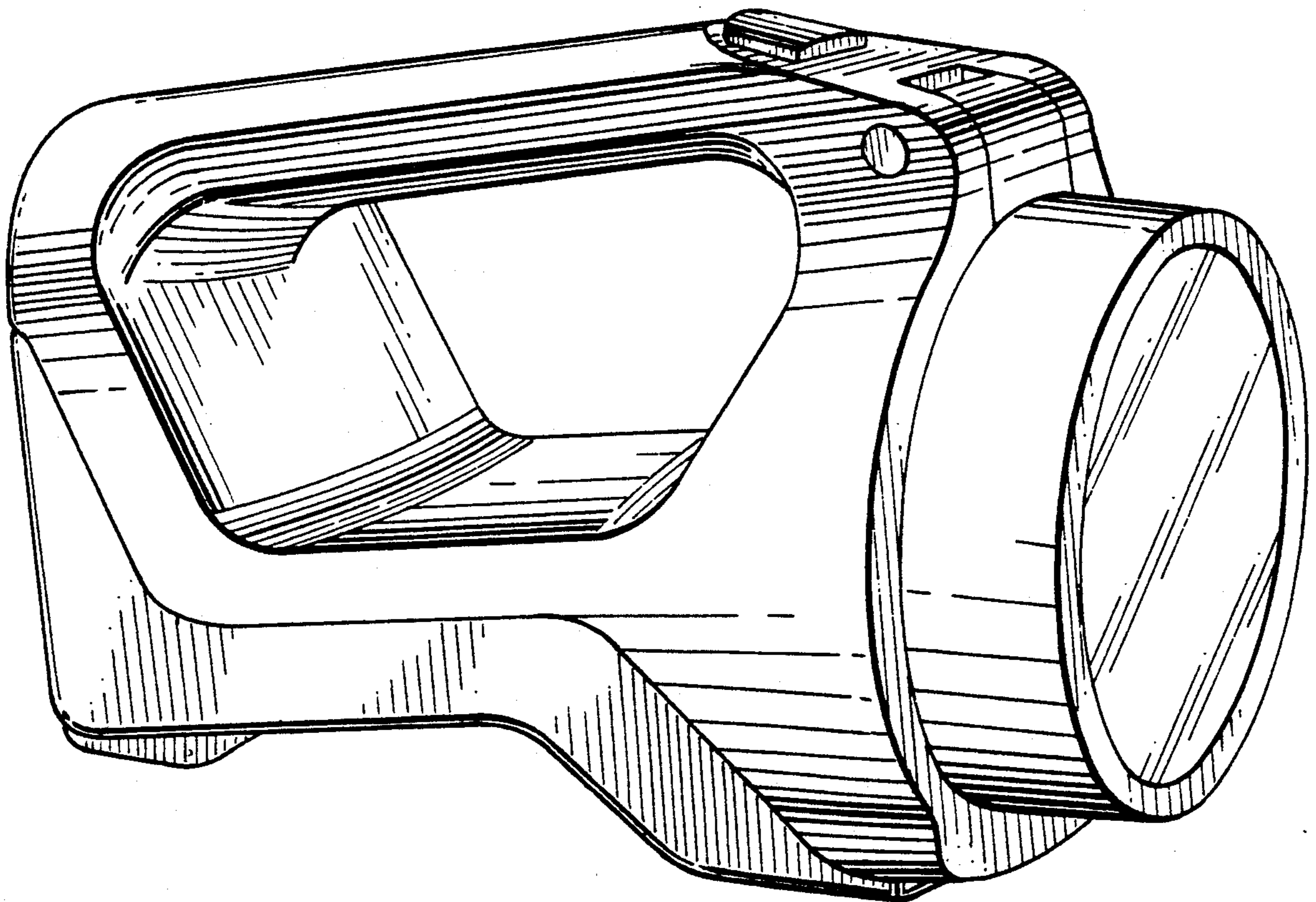

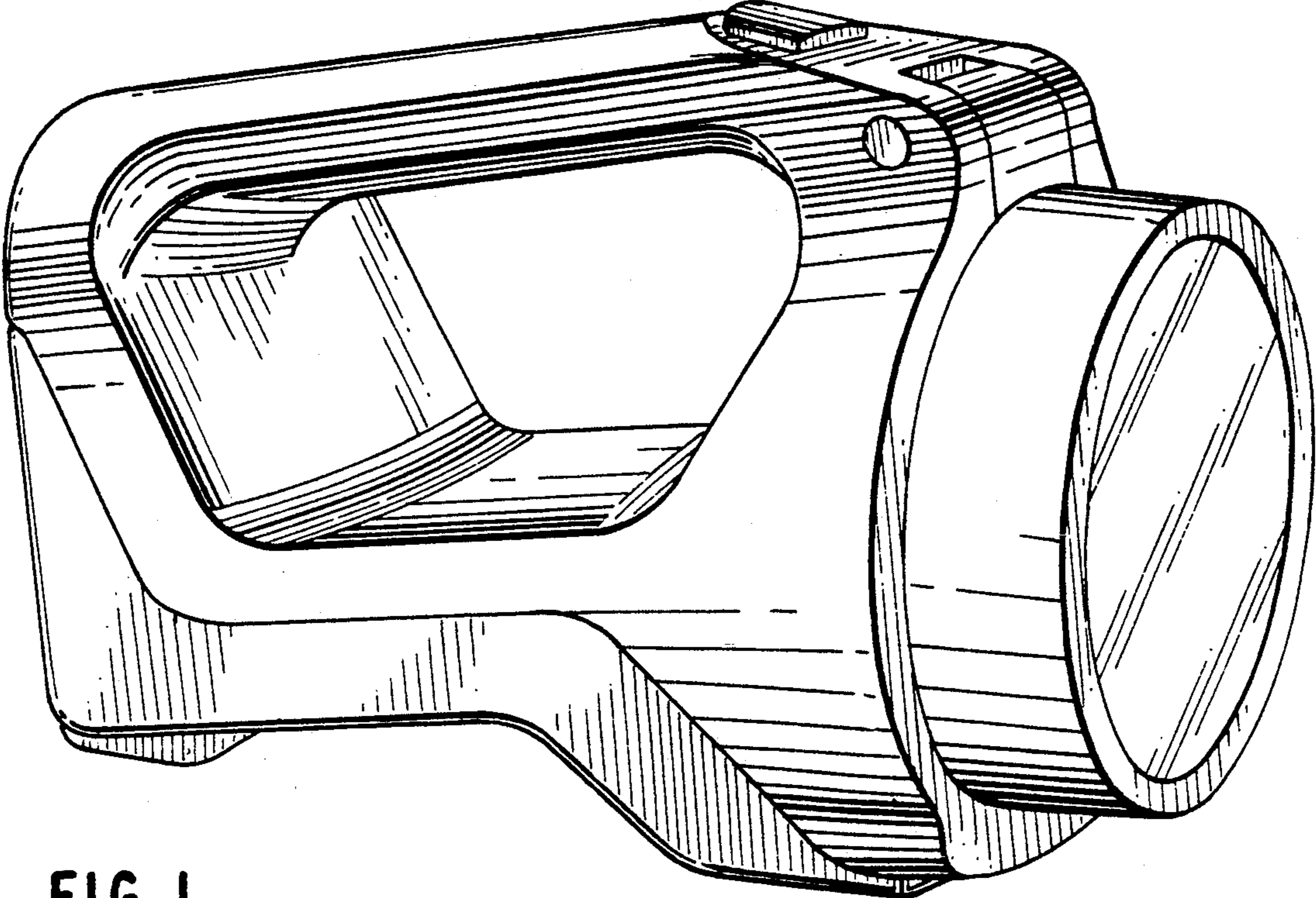

FIG. 1

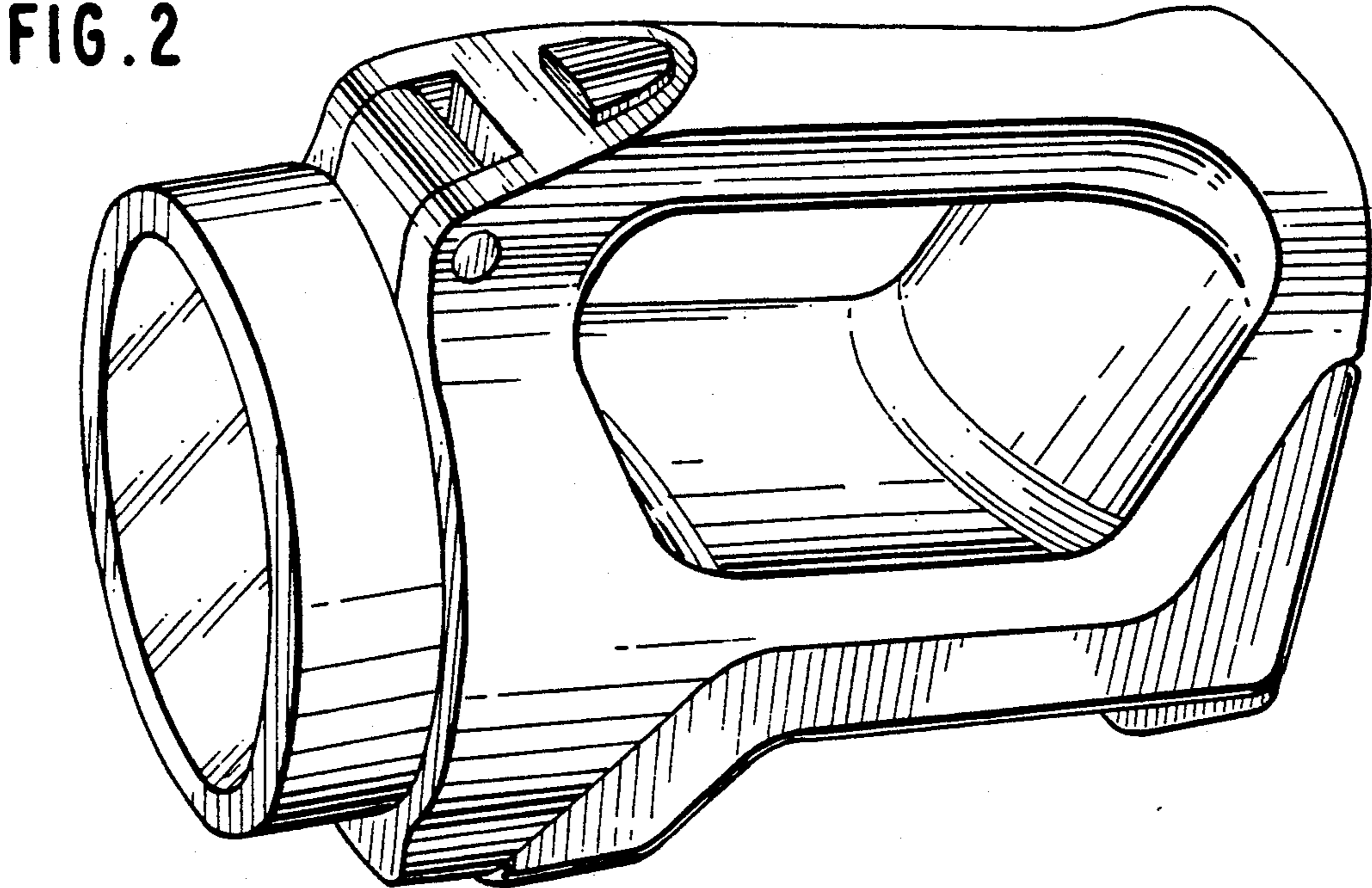

FIG. 2

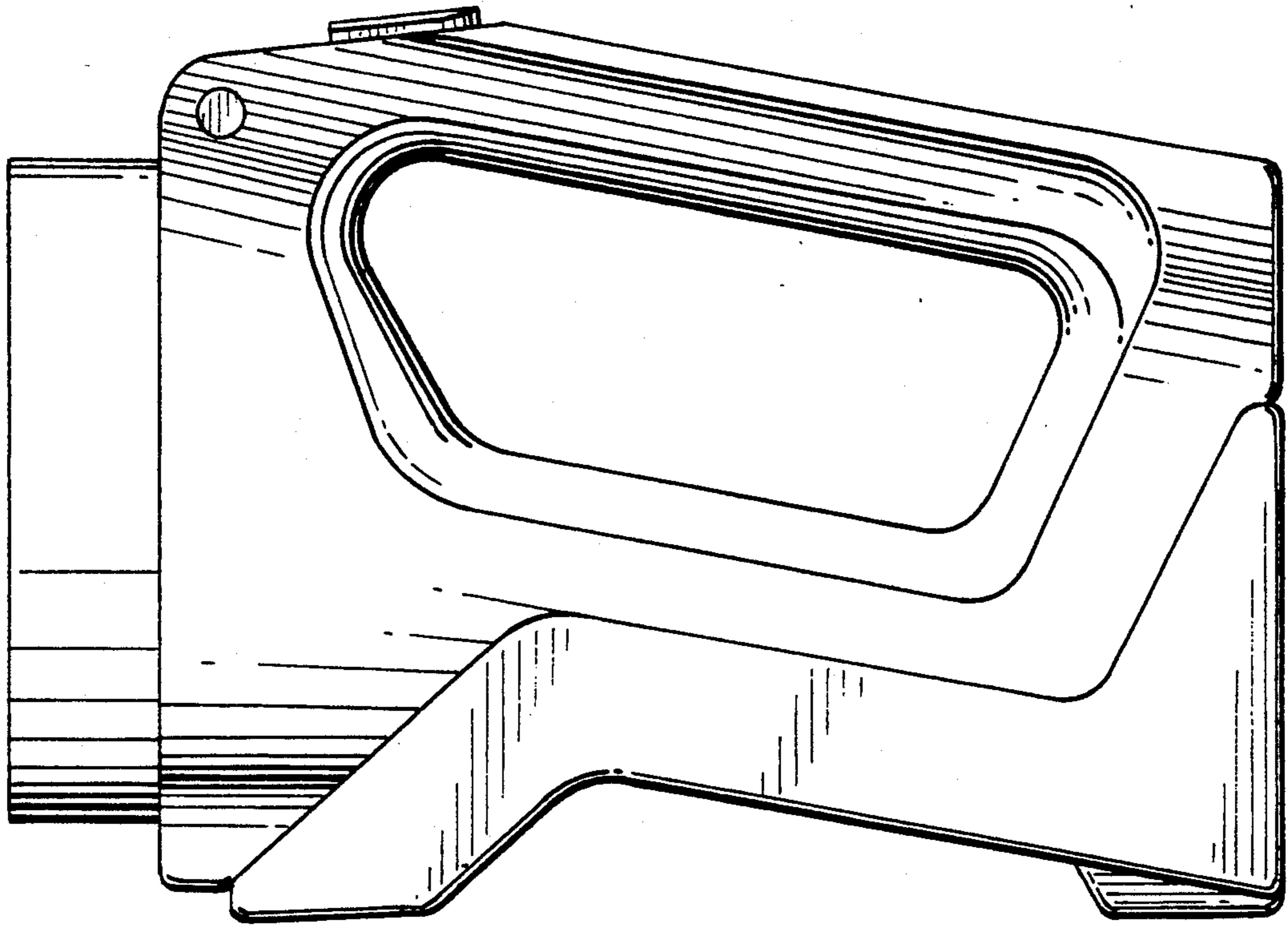

FIG. 3

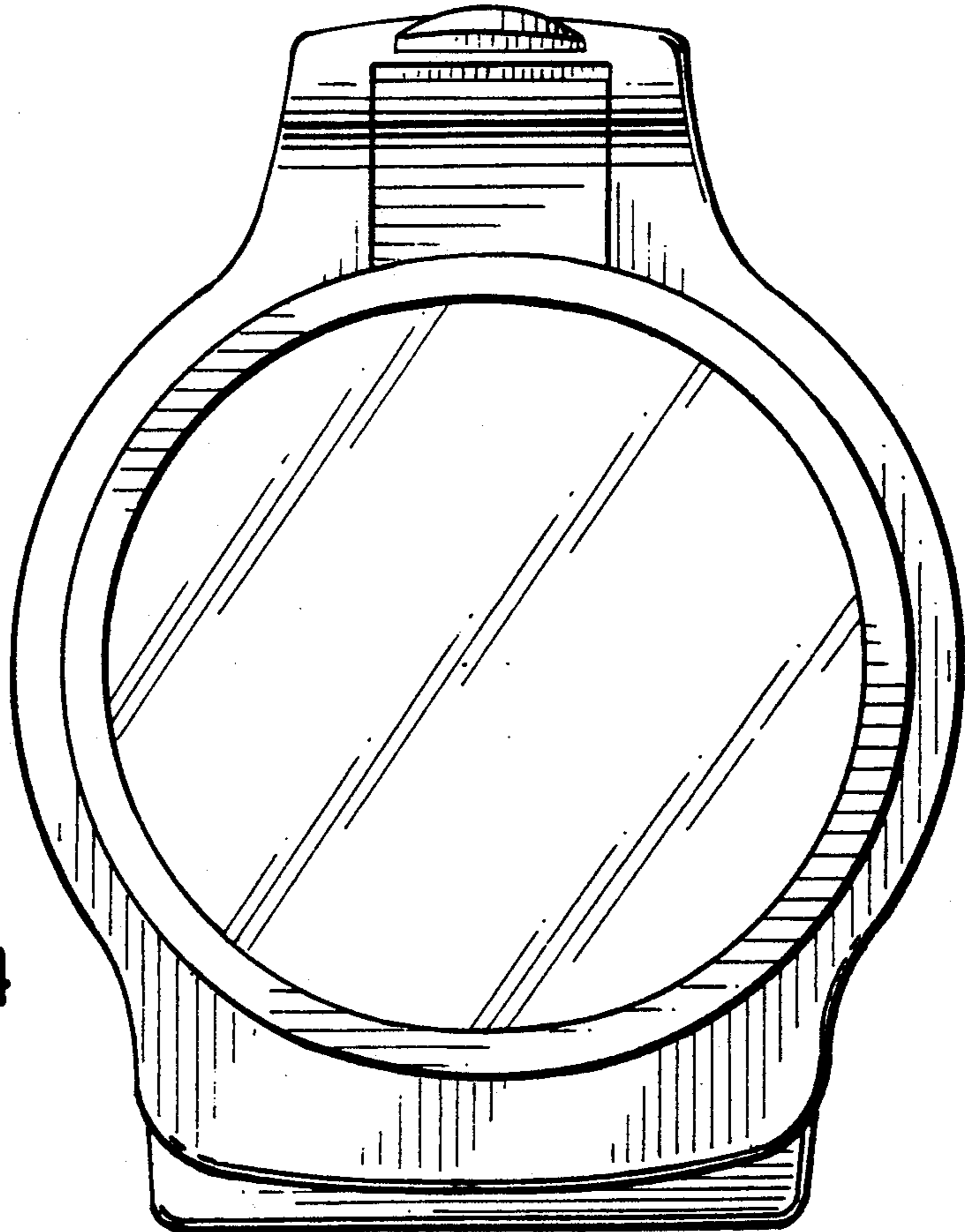

FIG. 4

FIG. 5

