



US00D337625S

United States Patent [19]

Uchida

[11] Patent Number: **Des. 337,625**

[45] Date of Patent: **** Jul. 20, 1993**

[54] **TOY VEHICLE**

[75] Inventor: **Yoshie Uchida, Tokyo, Japan**

[73] Assignee: **Tomy Company, Ltd., Tokyo, Japan**

[**] Term: **14 Years**

[21] Appl. No.: **806,132**

[22] Filed: **Dec. 12, 1991**

[30] **Foreign Application Priority Data**

Jun. 14, 1991 [JP] Japan 3-17875

[52] U.S. Cl. **D21/134**

[58] Field of Search **D21/73, 76-80, D21/124, 128, 134, 136, 139, 141, 141.1, 142, 161, 168, 177, 250; D12/85, 92, 128, 129; D19/63; 446/7, 279, 281, 451, 465; 280/47.36, 642-644, 658**

[56] **References Cited**

U.S. PATENT DOCUMENTS

D. 208,095 7/1967 Ostrander D21/134

D. 221,457 8/1971 Henderson D21/134
D. 239,553 4/1976 Breneman D21/134
D. 245,530 8/1977 Ferguson D21/168
D. 249,576 9/1978 Dunbar D21/134
D. 252,892 9/1979 Shigenori D21/134
D. 271,315 11/1983 Nottingham D21/79

Primary Examiner—Bernard Ansher
Assistant Examiner—R. Barkai
Attorney, Agent, or Firm—Staas & Halsey

[57] **CLAIM**

The ornamental design for a toy vehicle, as shown and described.

DESCRIPTION

FIG. 1 is a front elevational view of a toy vehicle showing my new design;
FIG. 2 is a rear elevational view thereof;
FIG. 3 is a left side elevational view thereof;
FIG. 4 is a right side elevational view thereof;
FIG. 5 is a top plan view thereof; and,
FIG. 6 is a bottom plan view.

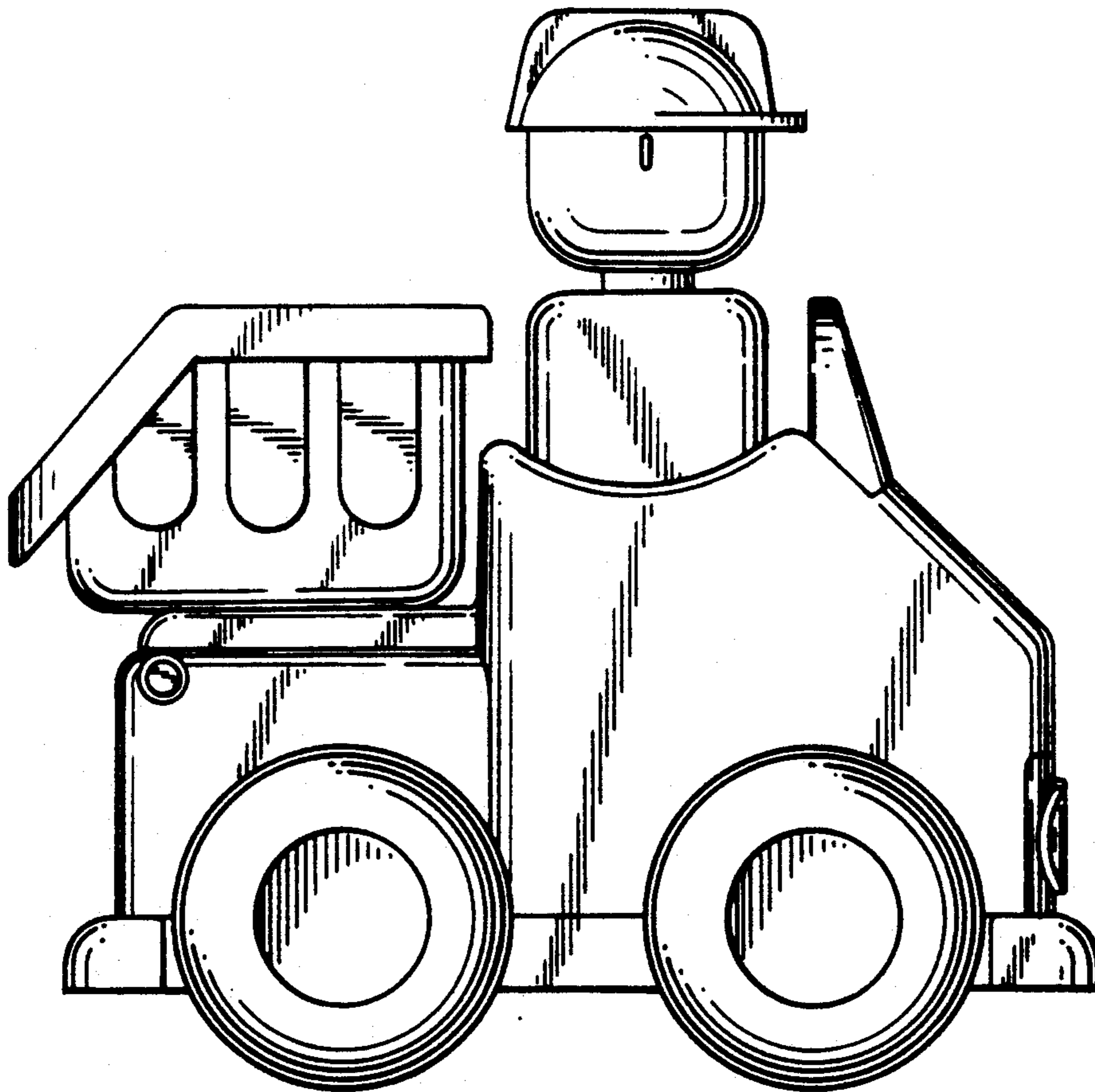

FIG. 1

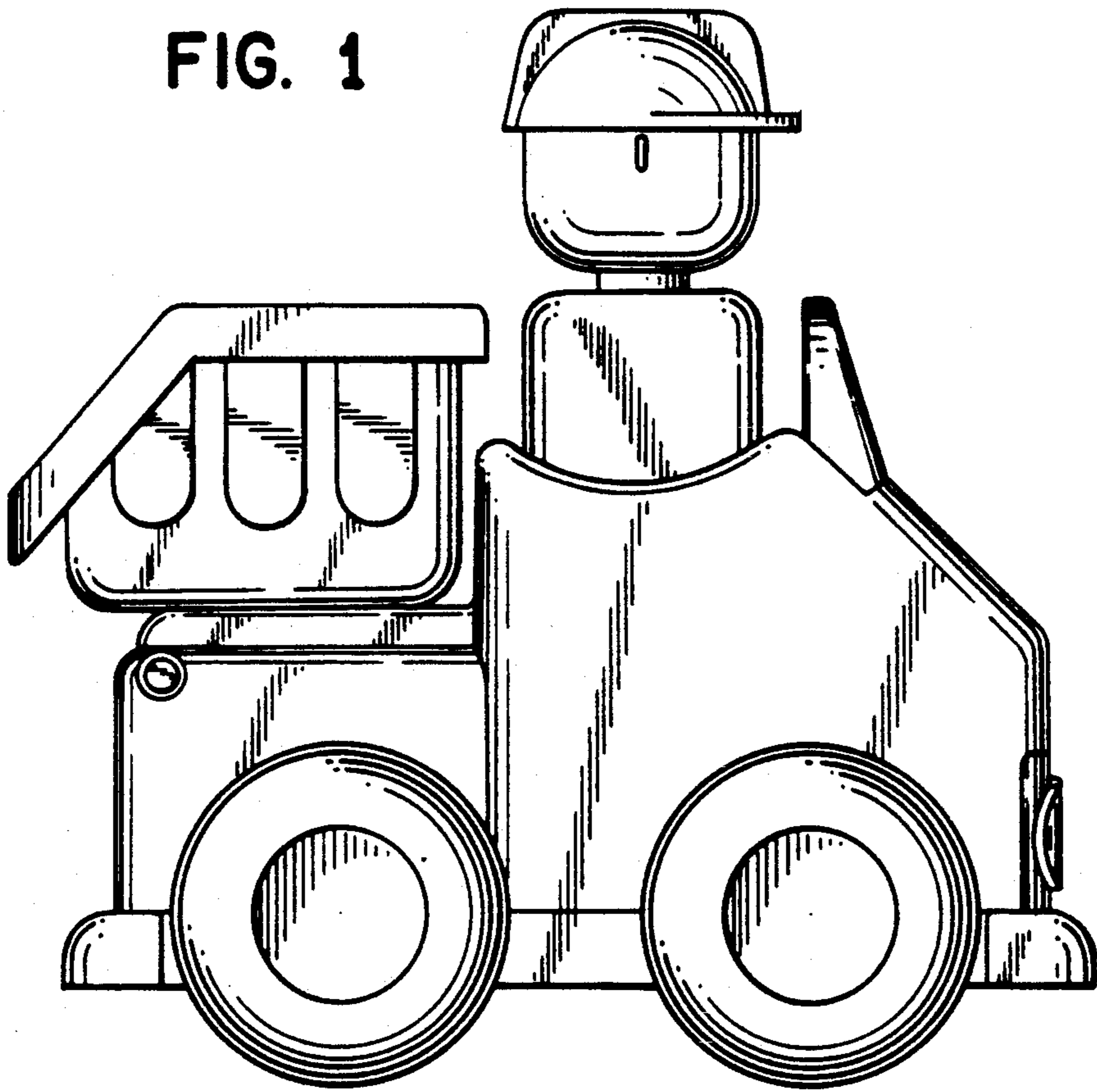

FIG. 2

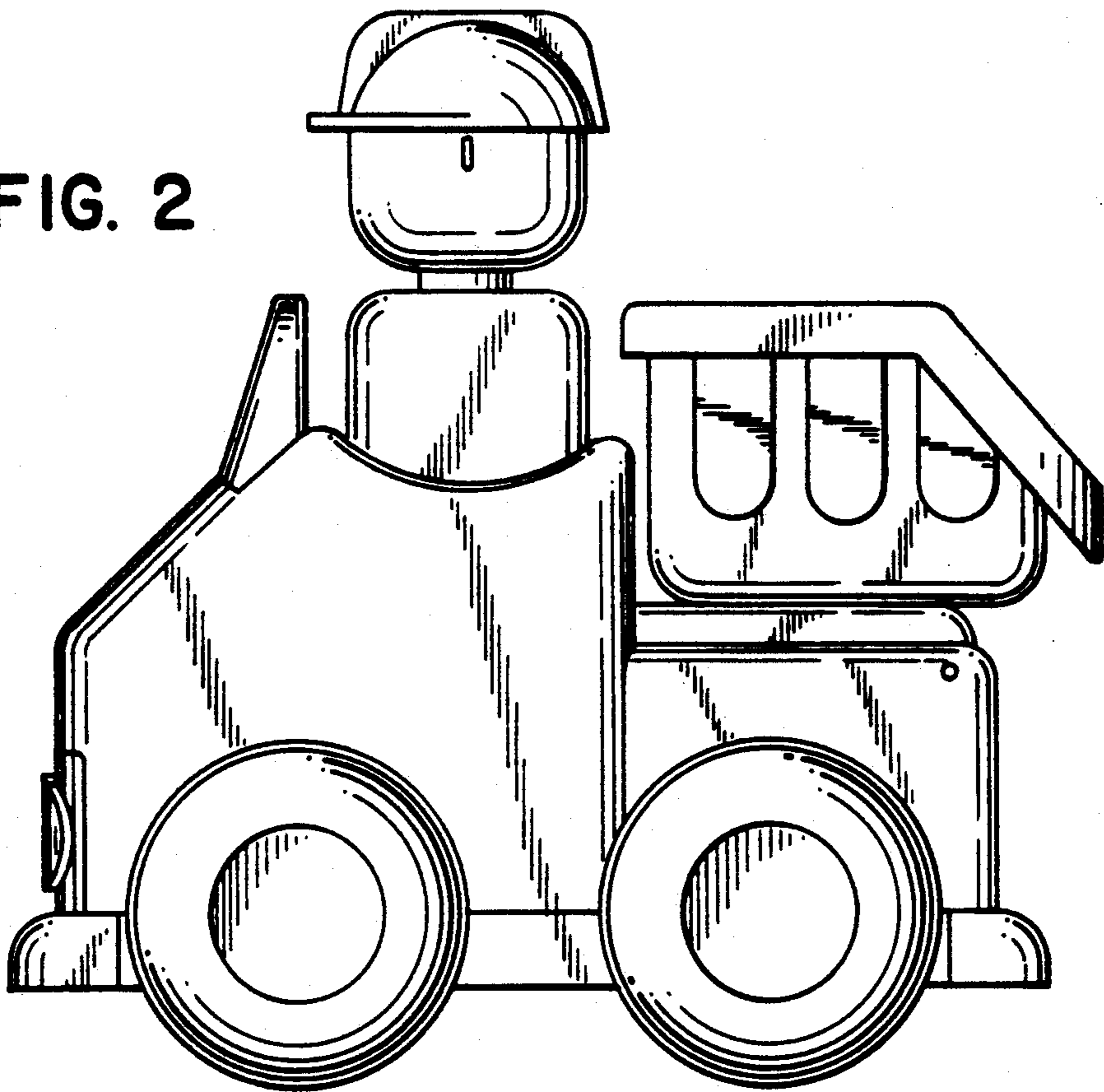

FIG. 3

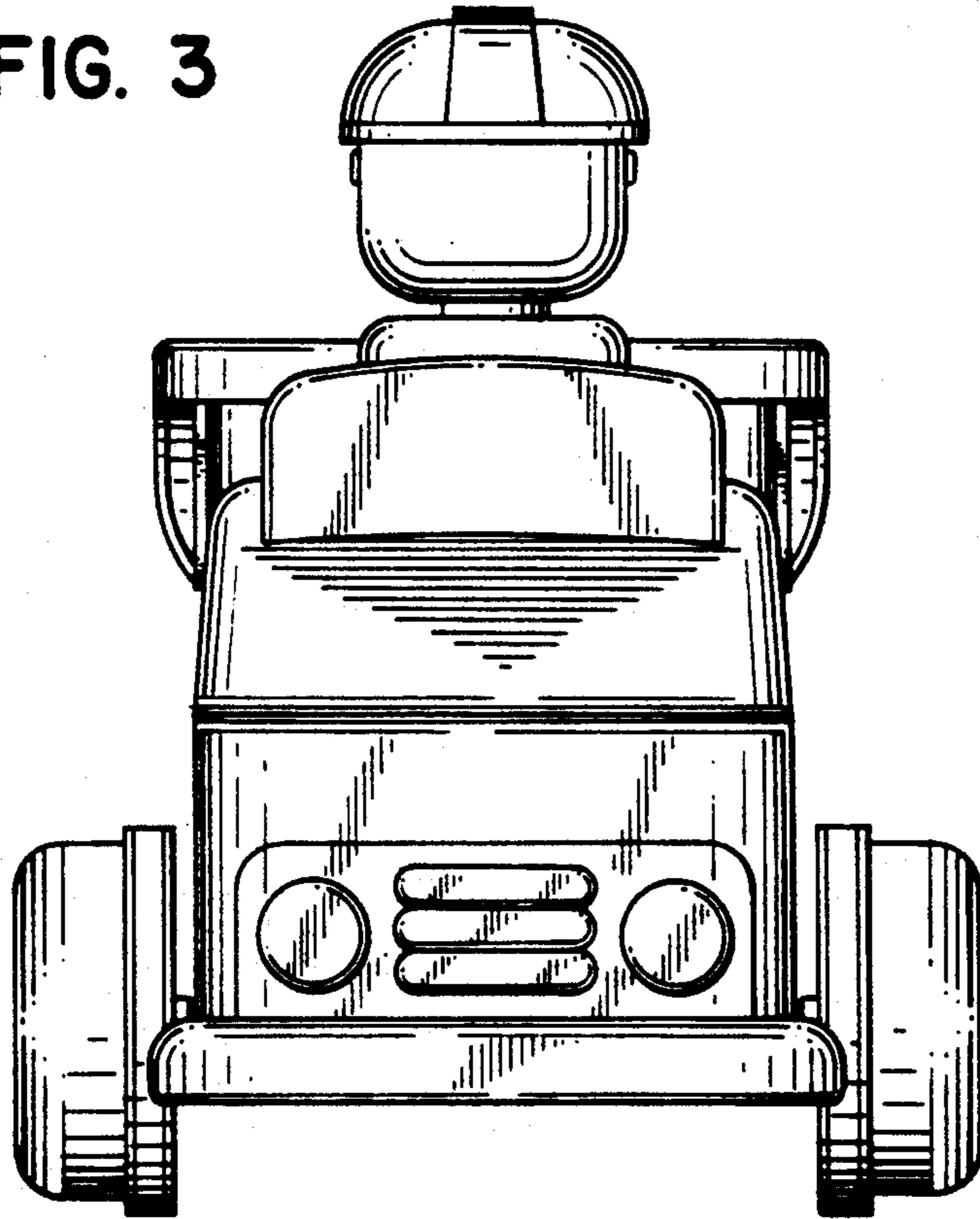

FIG. 4

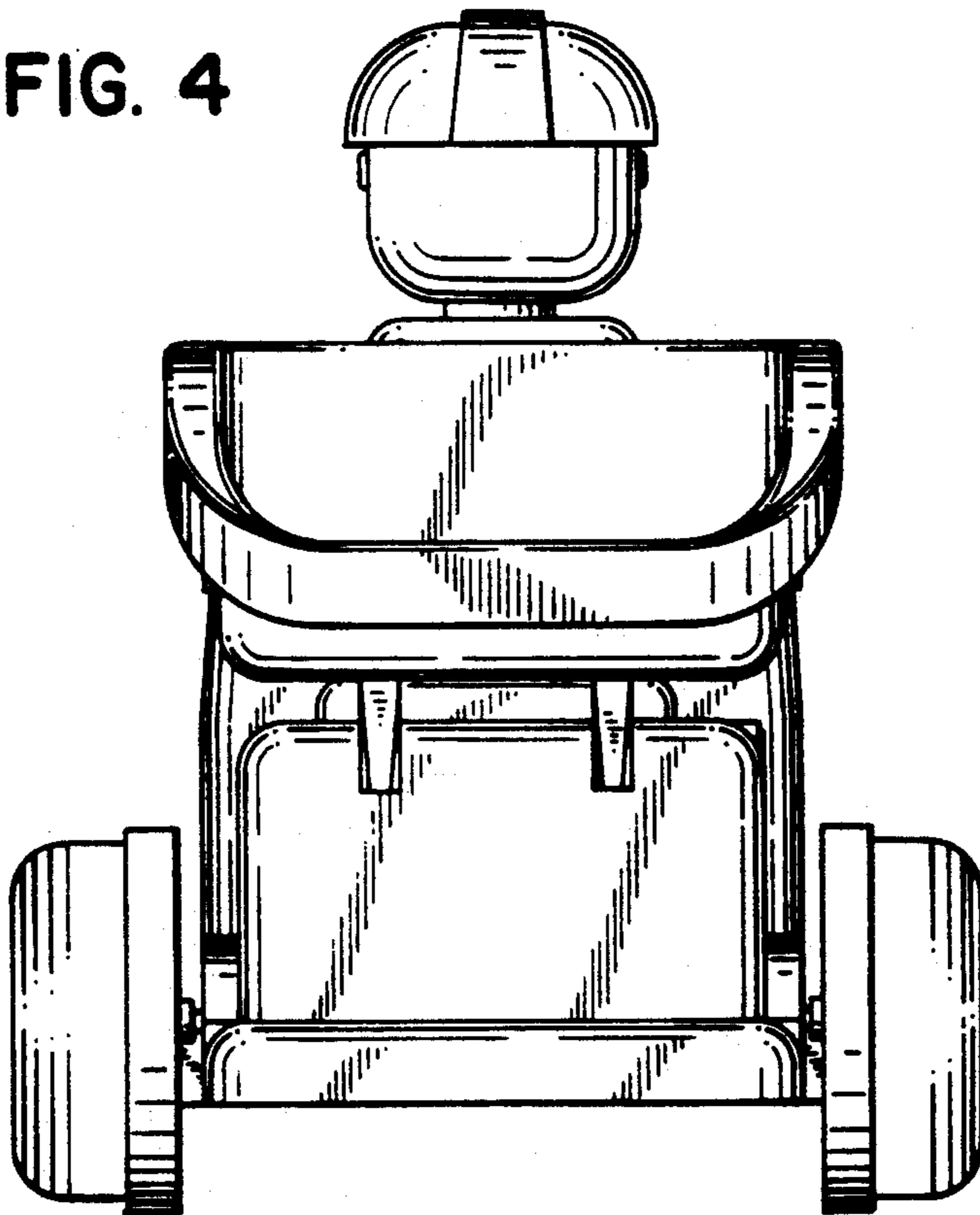

FIG. 5

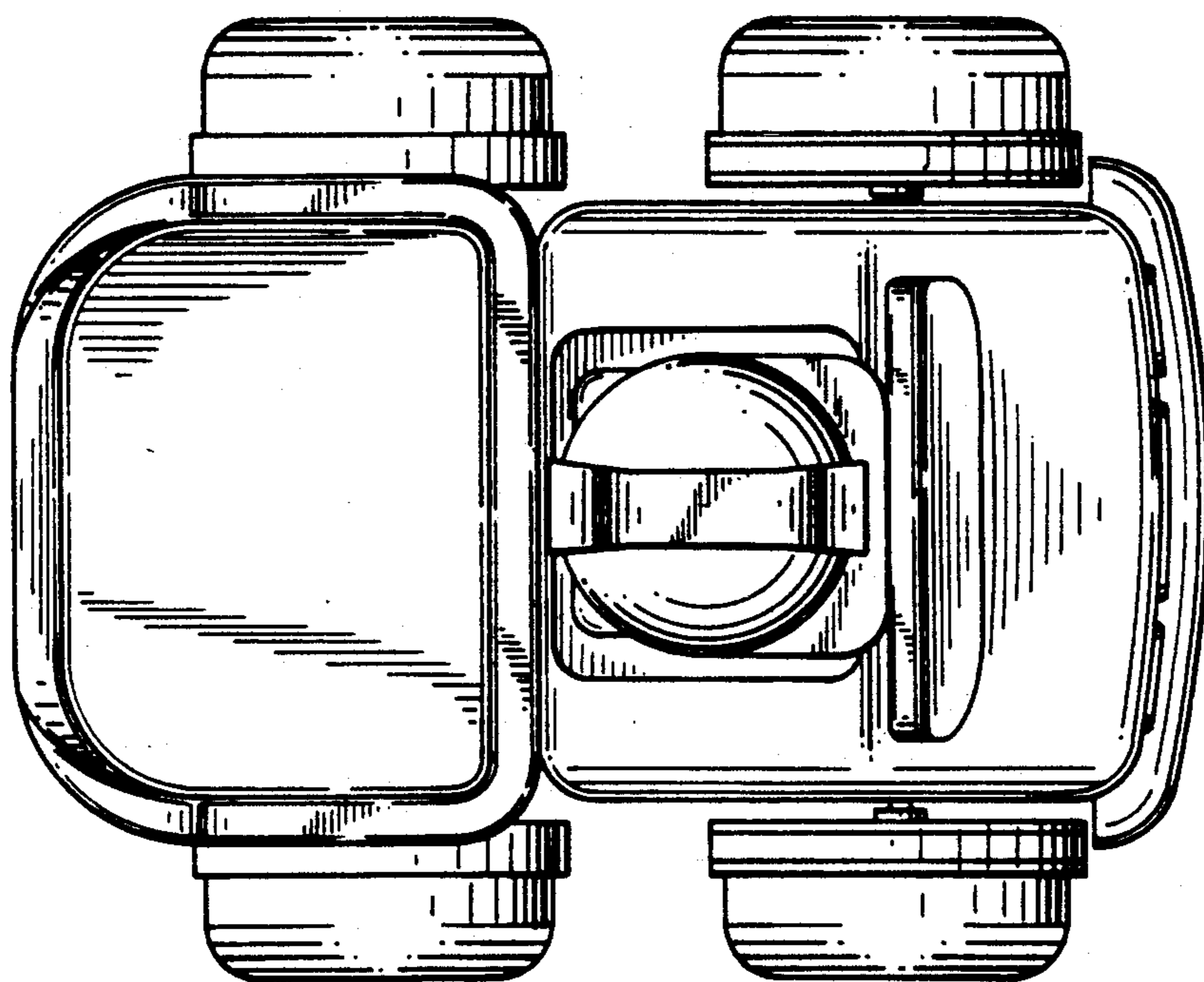

FIG. 6

