



US00D337616S

United States Patent [19]

[11] Patent Number: Des. 337,616

Stahel et al.

[45] Date of Patent: ** Jul. 20, 1993

[54] **COMBINED NOTE PAD AND WRITING INSTRUMENT HOLDER FOR ATTACHMENT TO AN AUTOMOBILE DASHBOARD, OR WINDOW**

3,016,262 12/1969 Hunt D12/191 X
5,028,026 7/1991 Philipps et al. 248/206.2

[75] Inventors: **Alwin J. Stahel, St. Paul; Peter R. Fervoy, Minneapolis, both of Minn.**

[73] Assignee: **Cobbs Manufacturing Company, Des Moines, Iowa**

[**] Term: **14 Years**

[21] Appl. No.: **354,685**

[22] Filed: **May 19, 1989**

[52] U.S. Cl. **D19/88; D19/78; D19/83; D19/90**

[58] Field of Search **D12/191; D19/65, 78, D19/83, 86, 92, 100; 248/441.1, 442.2, 206.2, 311.2, 314; 281/15.1, 51; 296/97.7; 224/311**

[56] **References Cited**

U.S. PATENT DOCUMENTS

D. 81,242	5/1930	John	D12/191
D. 119,284	3/1940	Rosenberg	D19/92 X
D. 164,173	8/1951	Ives	D19/78 X
D. 168,707	1/1953	Pavenick	D12/191
D. 234,511	3/1985	Mori	D19/78
D. 245,458	8/1977	Haus et al.	D19/78 X
D. 273,002	3/1984	Schafer	D12/191
D. 299,475	1/1989	Munnik	D19/78
D. 313,046	12/1990	Colani	D19/86 X

OTHER PUBLICATIONS

Hong Kong Enterprise, Mar. 1987, see p. 210, dashboard mountable clipboard lower left center-Desk copy.

Hong Kong Enterprise, Mar. 1987, see p. 251, clipboard portfolio, lower left-Desk copy.

Primary Examiner—Alan P. Douglas

Assistant Examiner—Martha Thompson

Attorney, Agent, or Firm—Dick and Harris

[57] CLAIM

The ornamental design for a combined note pad and writing instrument holder for attachment to an automobile dashboard, window, as shown and described.

DESCRIPTION

FIG. 1 is a front elevational view of a combined note pad and writing instrument holder for attachment to an automobile dashboard, window or the like showing our new design;

FIG. 2 is a right side elevational view;

FIG. 3 is a rear elevational view;

FIG. 4 is a front elevational view with the cover member in an open position;

FIG. 5 is a bottom plan view of FIG. 4;

FIG. 6 is a left side elevational view; and,

FIG. 7 is a top plan view thereof.

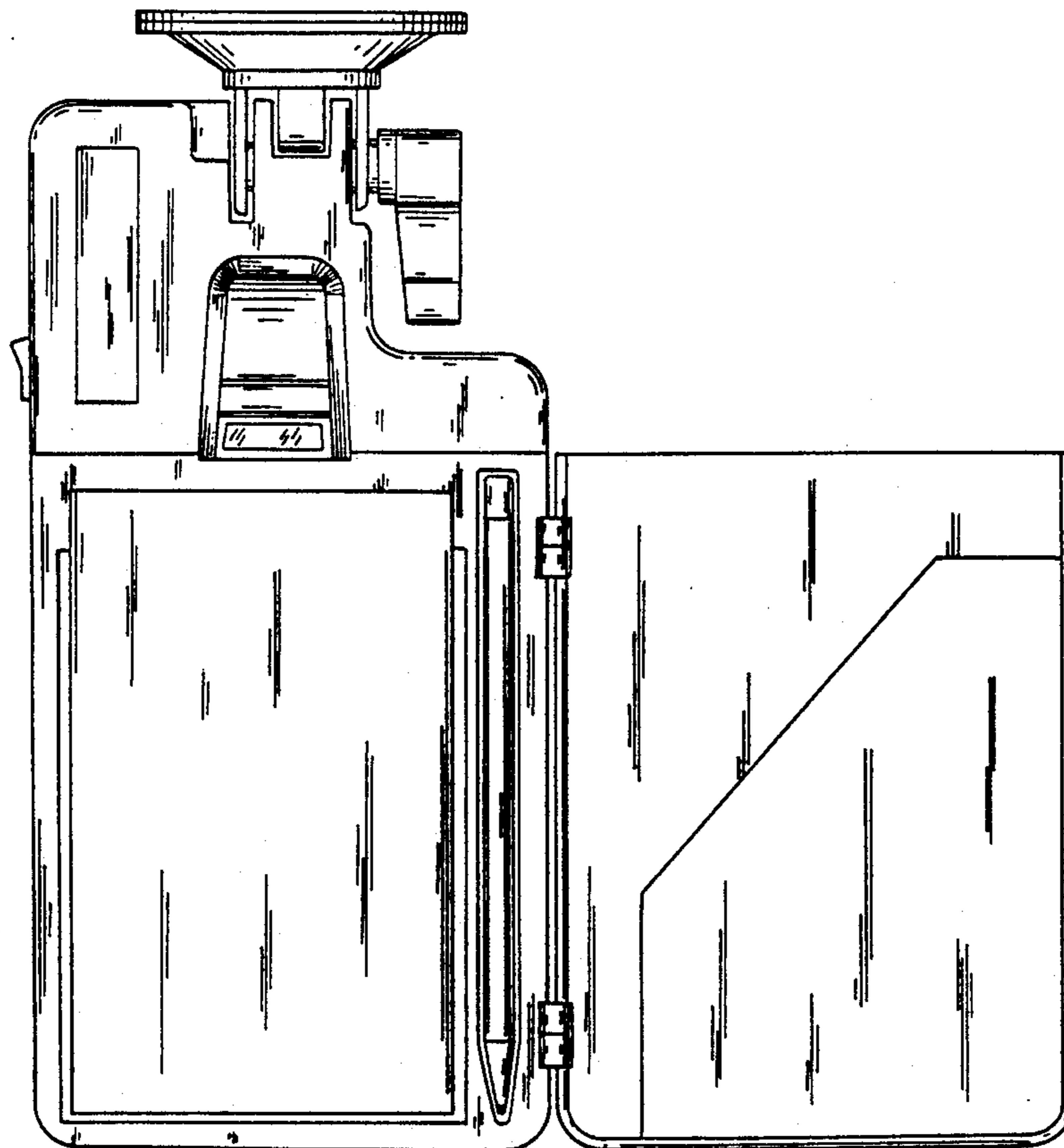

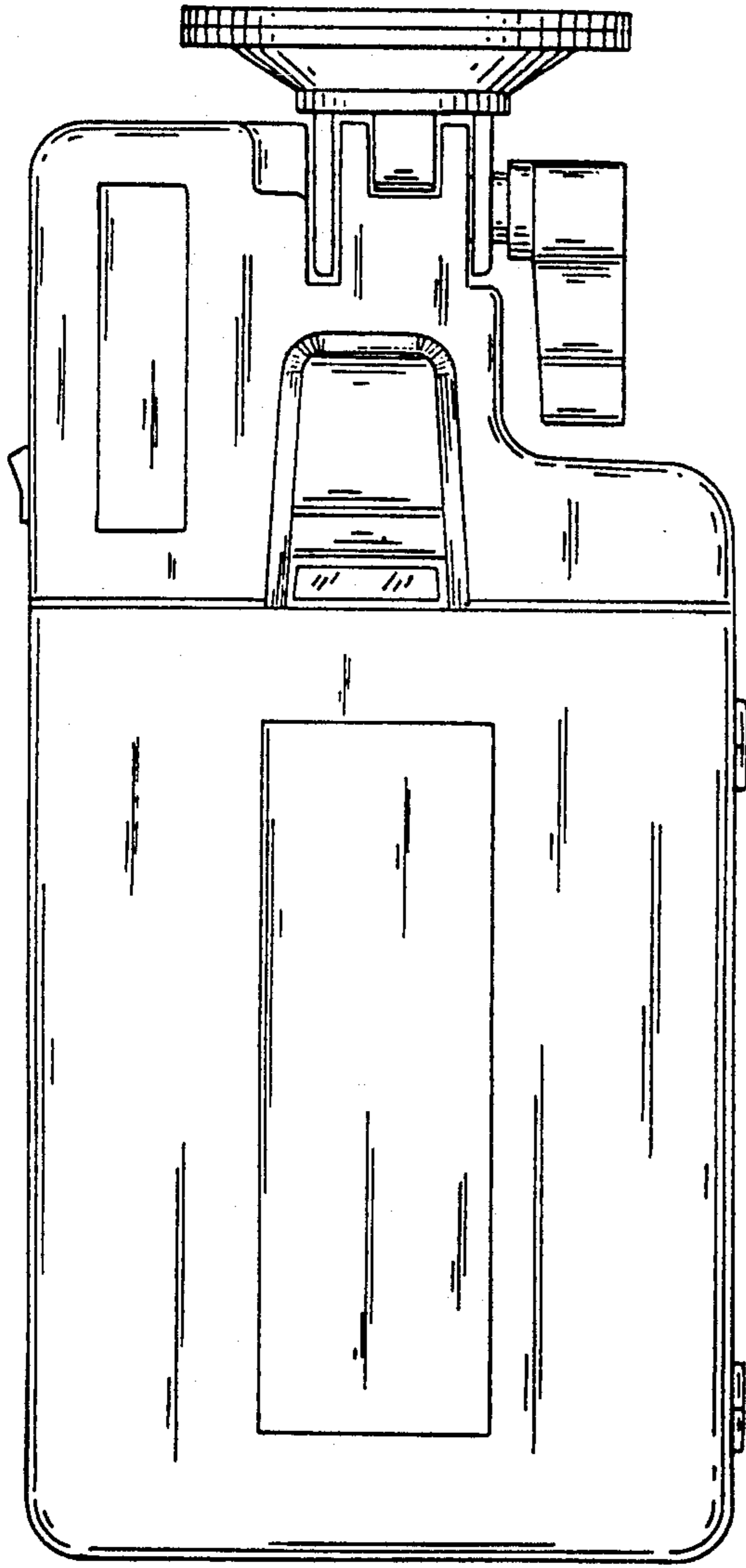

FIG. 1

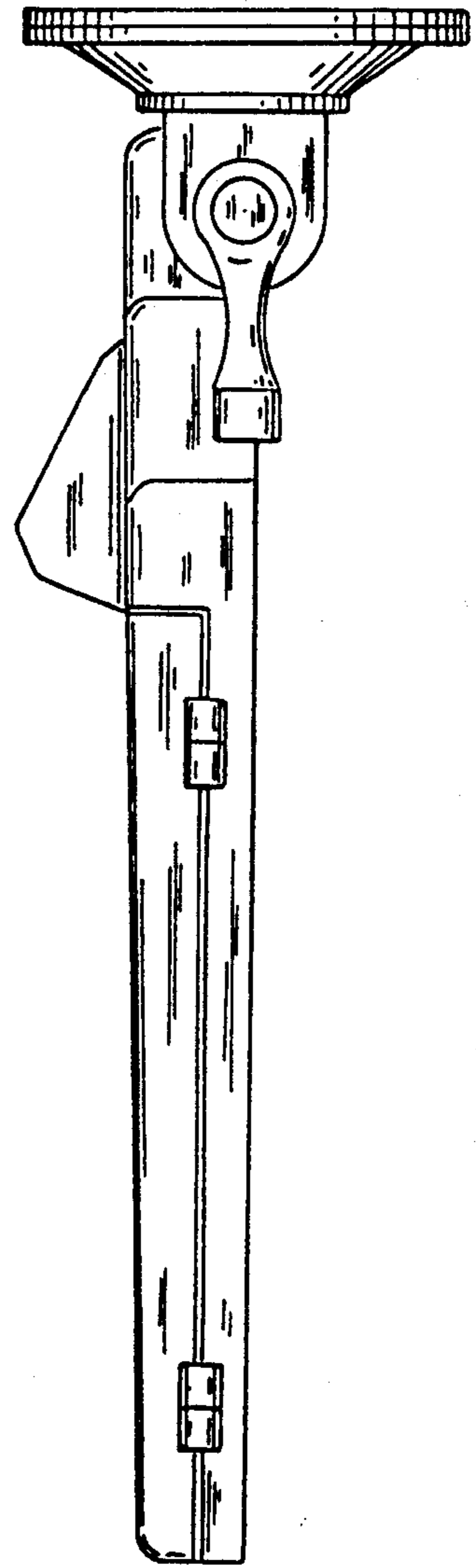

FIG. 2

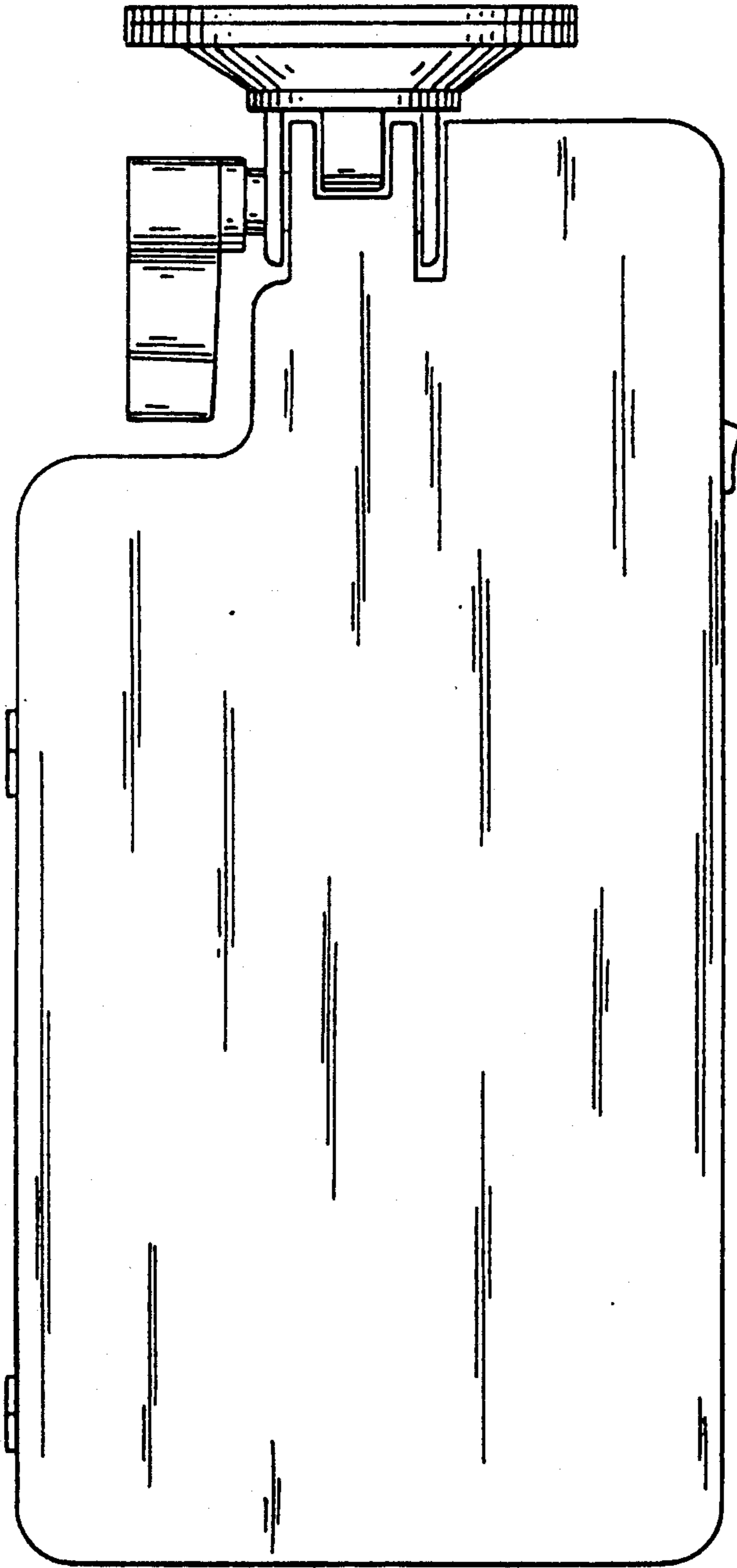

FIG. 3

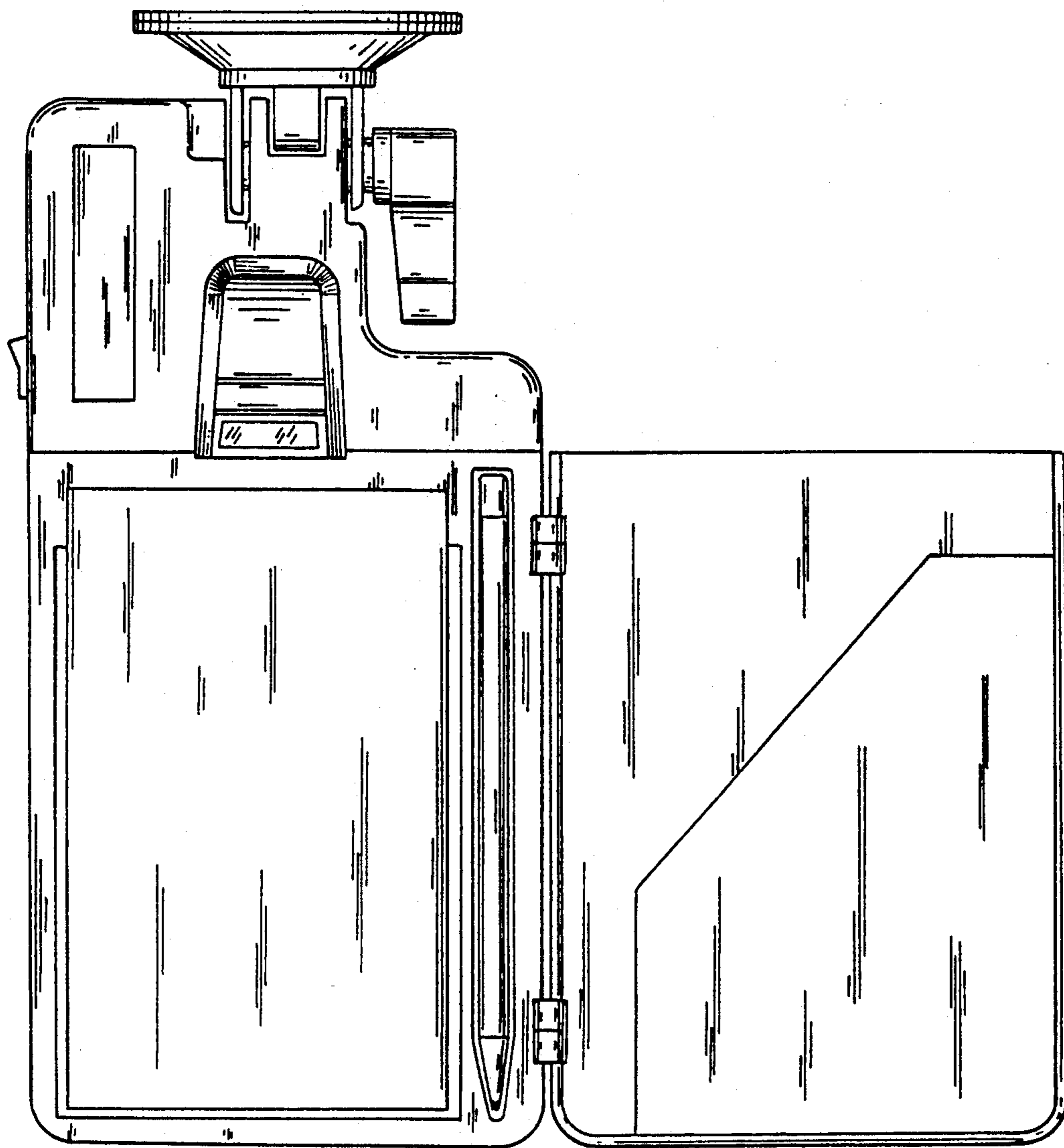

FIG. 4

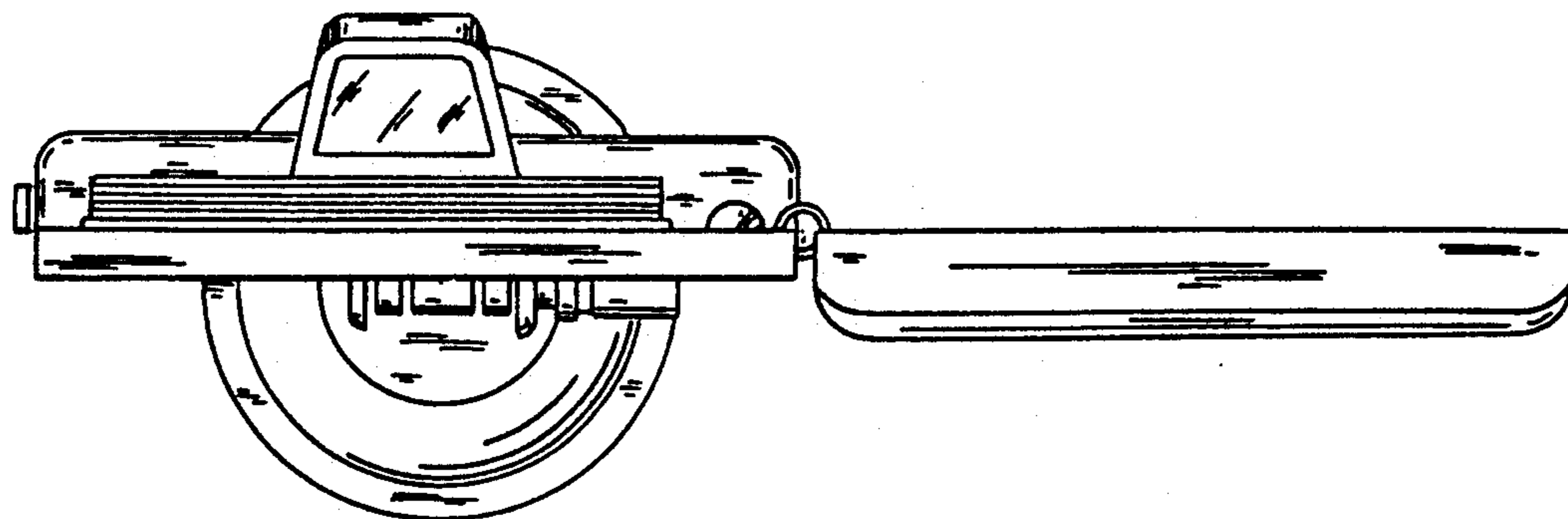

FIG. 5

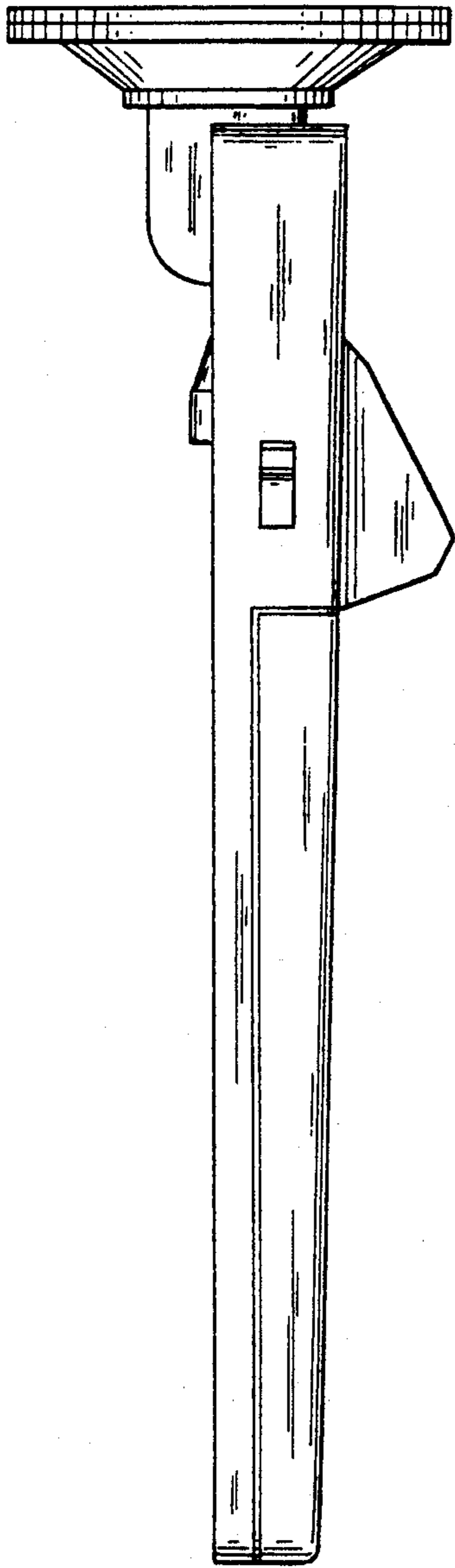

FIG. 6

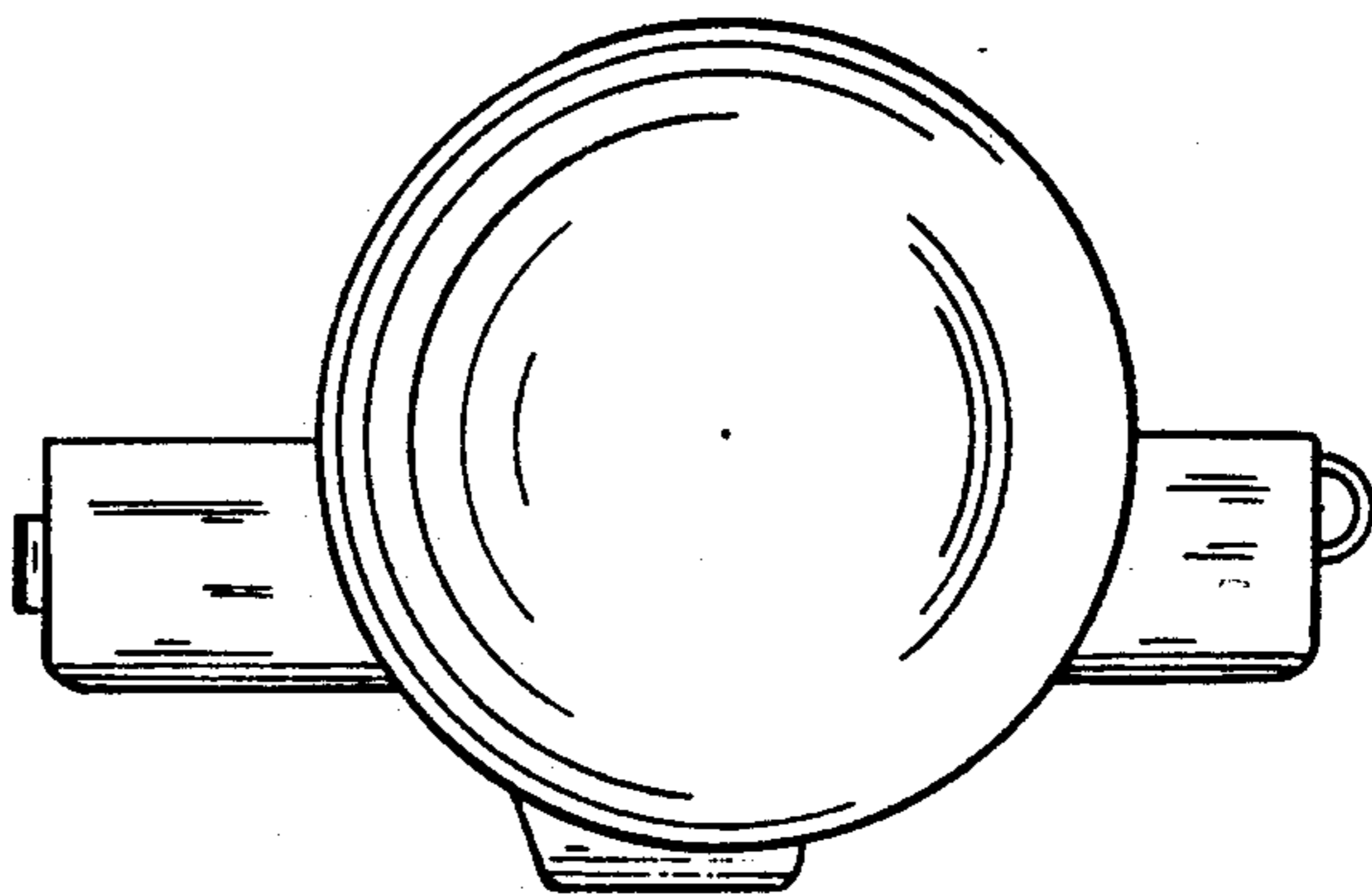

FIG. 7