



US00D337560S

United States Patent [19]

Steinke et al.

[11] Patent Number: **Des. 337,560**

[45] Date of Patent: **** Jul. 20, 1993**

[54] **DISC BRAKE SHIM**

[75] Inventors: **Gustav J. Steinke; Starla D. Huffer,**
both of Lima, Ohio

[73] Assignee: **International Brake Industries, Inc.,**
Lima, Ohio

[**] Term: **14 Years**

[21] Appl. No.: **798,689**

[22] Filed: **Nov. 26, 1991**

[52] U.S. Cl. **D12/180**

[58] Field of Search **D12/180; 188/73.1, 250 B**

[56] **References Cited**

U.S. PATENT DOCUMENTS

- D. 279,467 7/1985 Eberhart et al. D12/180
- 4,220,223 9/1980 Rinker et al. 188/73.1
- 4,926,978 5/1990 Shibata et al. 188/73.1

FOREIGN PATENT DOCUMENTS

- 2404671 7/1975 Fed. Rep. of Germany 180/73.1

OTHER PUBLICATIONS

J. C. Whitney & Co. Catalog No. 505 M, ©1989, p. 259,
the semi-metallic disc brake pad(B).

Primary Examiner—Wallace R. Burke
Assistant Examiner—Melody N. Brown
Attorney, Agent, or Firm—Edgar A. Zarins; Malcolm L.
Sutherland

[57] **CLAIM**

The ornamental design for a disc brake shim, as shown.

DESCRIPTION

FIG. 1 is an elevated perspective of a first embodiment of a disc brake shim showing our new design; FIG. 2 is a left side elevational view thereof; FIG. 3 is a front elevational view thereof; FIG. 4 is a top plan view thereof; FIG. 5 is a right side elevational view thereof; FIG. 6 is a rear elevational view thereof; FIG. 7 is a bottom plan view thereof; and, FIG. 8 is an elevated perspective of a second embodiment of the disc brake shim.

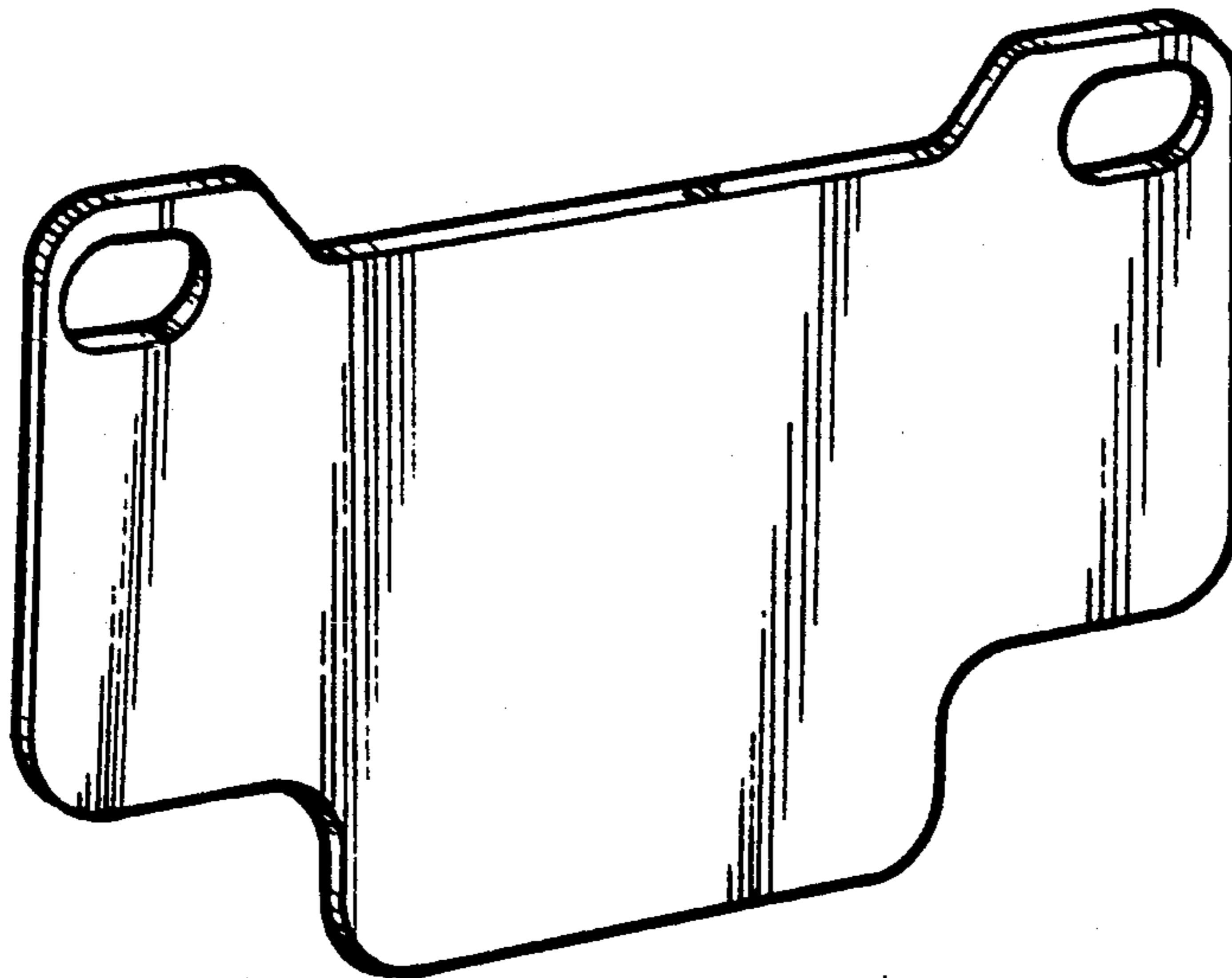

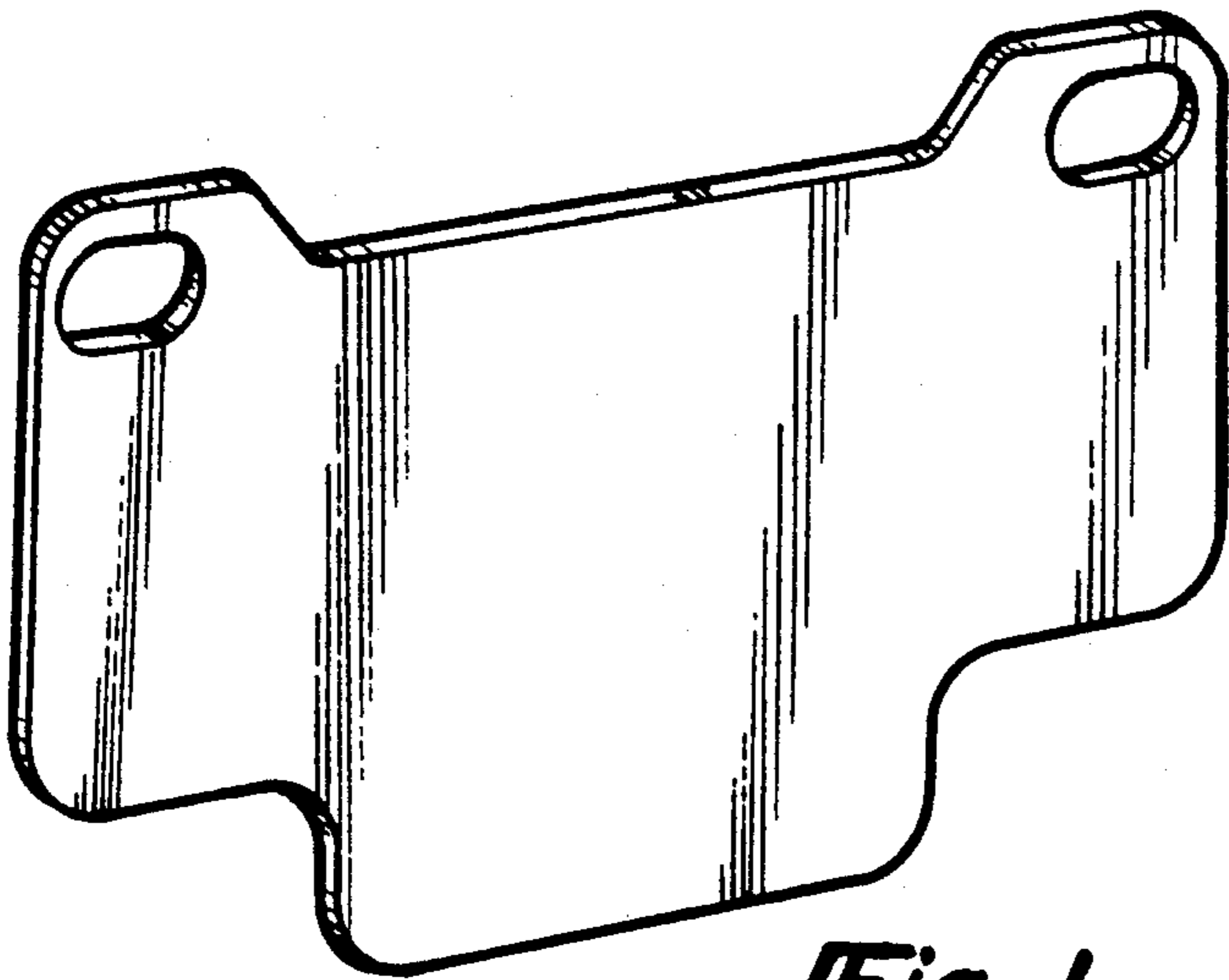

Fig-1

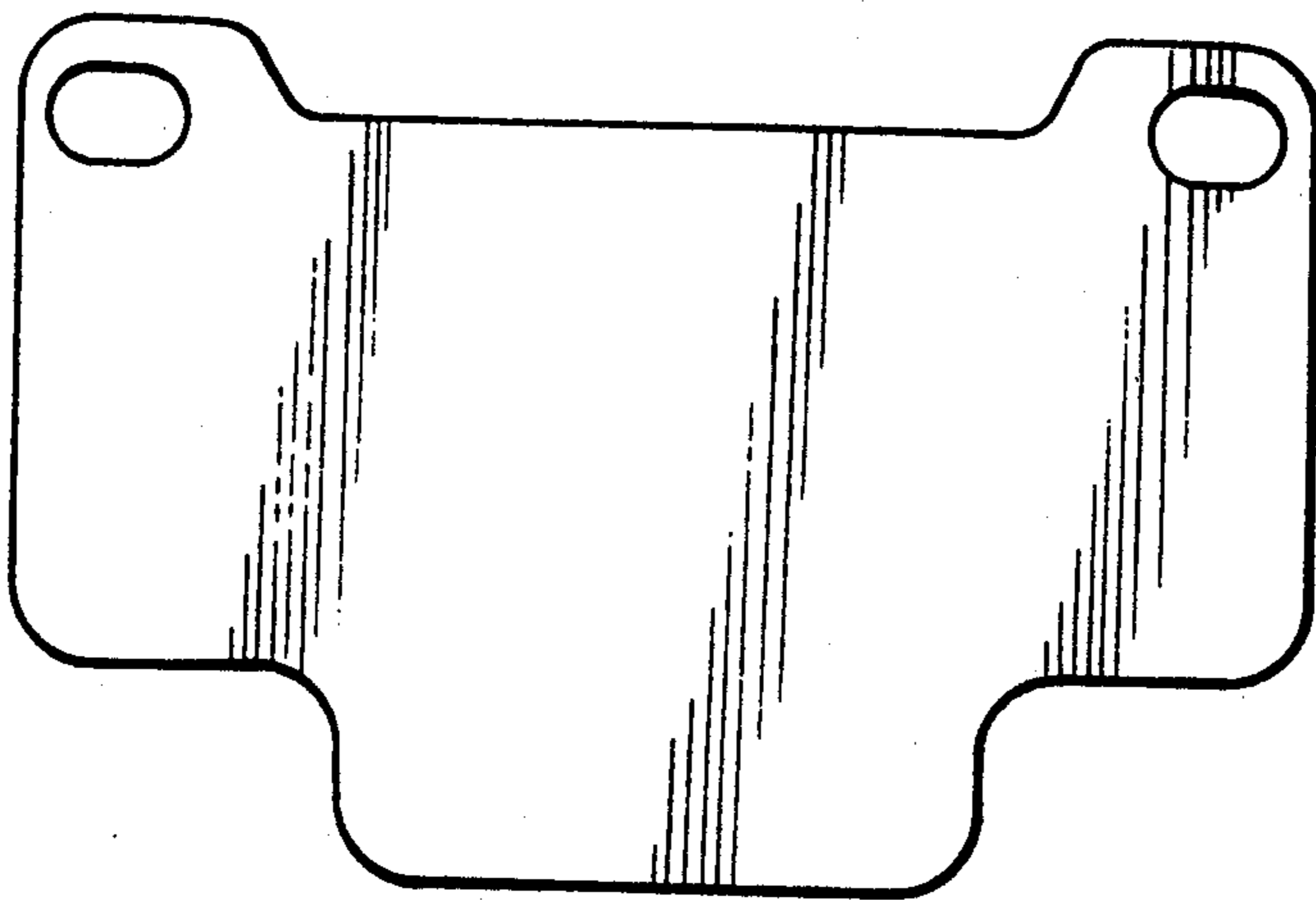

Fig-3



Fig-4



Fig-2



Fig-5

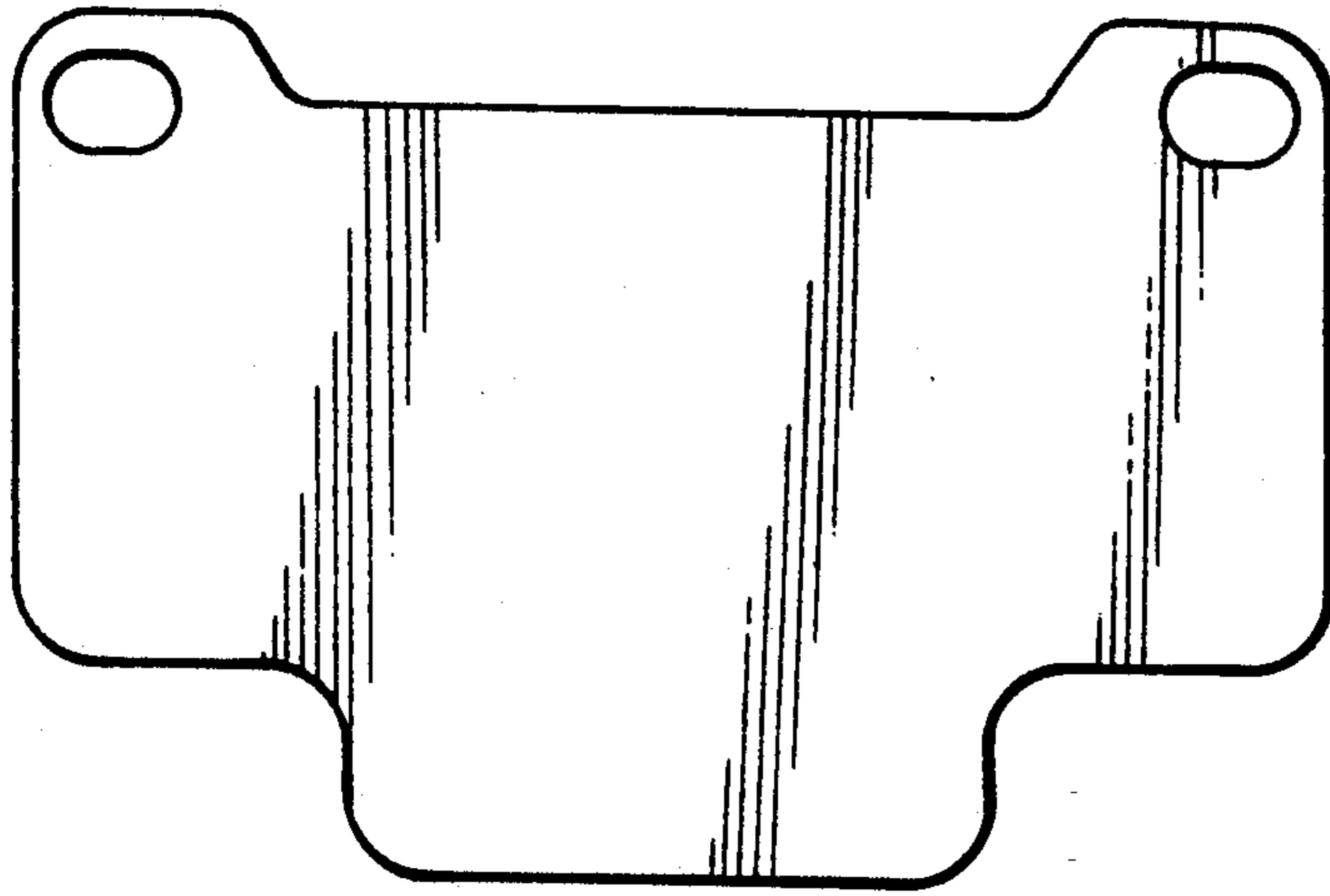

Fig-6



Fig-7

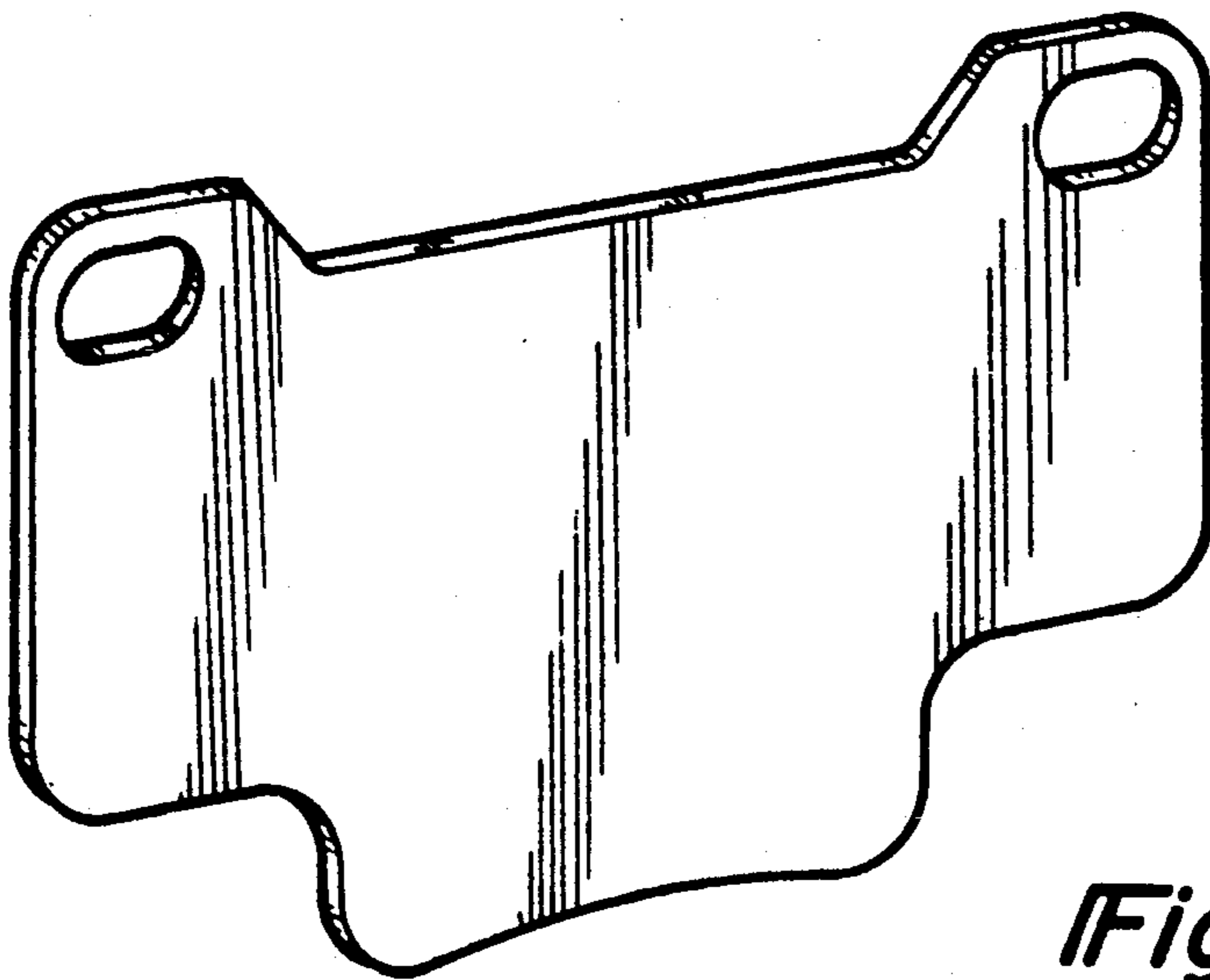

Fig-8