



US00D337325S

# United States Patent [19]

Nakamaru

[11] Patent Number: **Des. 337,325**

[45] Date of Patent: **\*\* Jul. 13, 1993**

[54] SHELL FOR MAGNETIC TAPE CASSETTE

[75] Inventor: **Kazuki Nakamaru, Sendai, Japan**

[73] Assignee: **Sony Corporation, Tokyo, Japan**

[\*\*] Term: **14 Years**

[21] Appl. No.: **657,314**

[22] Filed: **Feb. 15, 1991**

[30] Foreign Application Priority Data

Aug. 15, 1990 [JP] Japan ..... 2-27614

[52] U.S. Cl. .... **D14/121**

[58] Field of Search ..... D14/114, 120-122,  
D14/299; 242/55.19 A, 197-200; 273/DIG. 28,  
85 G

[56] References Cited

### U.S. PATENT DOCUMENTS

D. 221,438 8/1971 Saito ..... D14/121

D. 222,911 2/1972 Weiss ..... D14/121

D. 223,029 2/1972 Weiss ..... D14/121

D. 276,910 12/1984 Lohrer et al. .... D14/121

D. 308,866 6/1990 Kinoshita et al. .... D14/120 X

*Primary Examiner*—Theodore M. Shooman  
*Attorney, Agent, or Firm*—Lewis H. Eslinger; Jay H. Maioli

### [57] CLAIM

The ornamental design for a shell for magnetic tape cassette, as shown and described.

### DESCRIPTION

FIG. 1 is a top, front and right-side perspective view of a shell for magnetic tape cassetts showing my new design;

FIG. 2 is a front elevational view thereof;

FIG. 3 is a rear elevational view thereof;

FIG. 4 is a right-side elevational view thereof, the left side being a mirror image thereof;

FIG. 5 is a top plan view thereof; and,

FIG. 6 is a bottom plan view thereof.

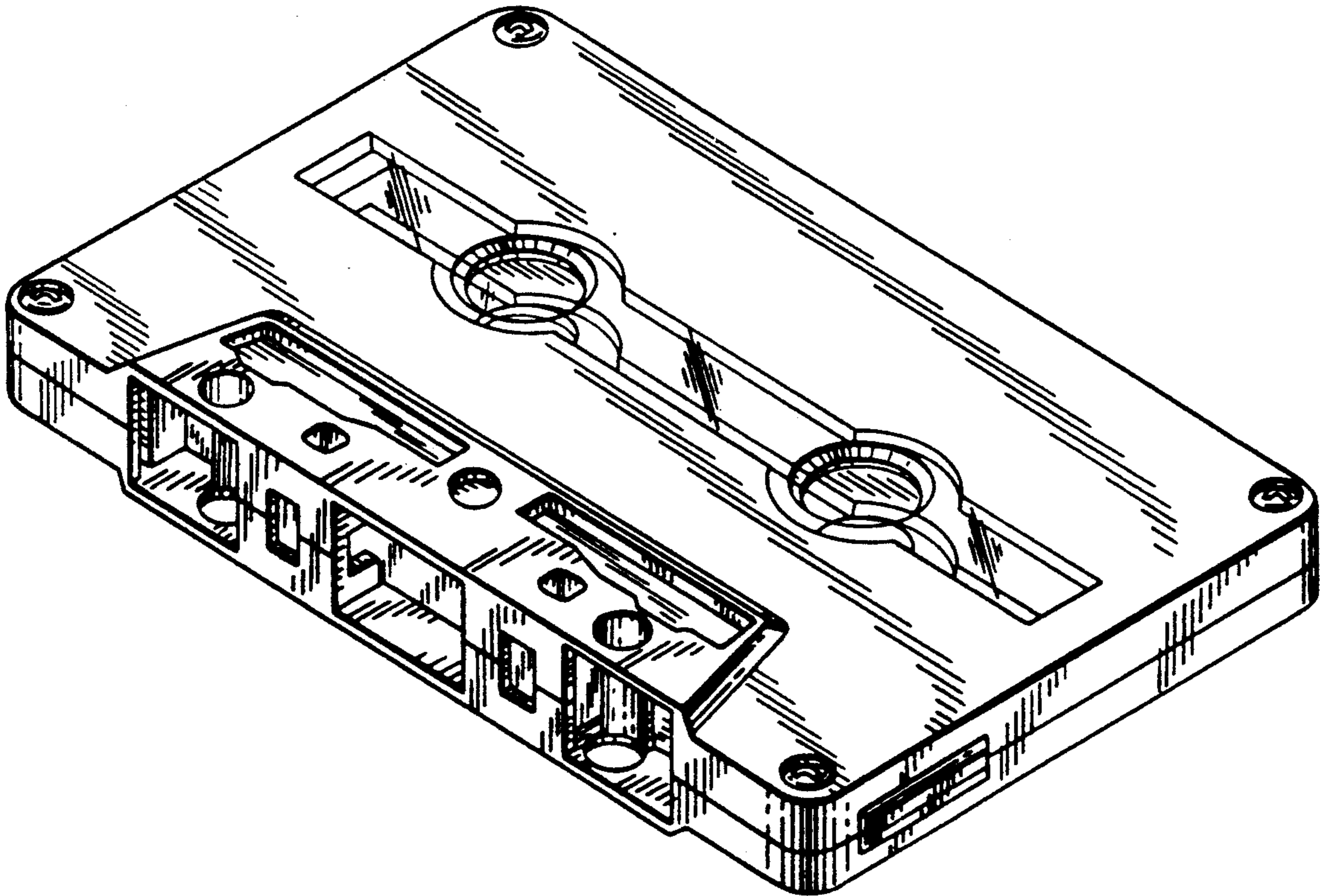

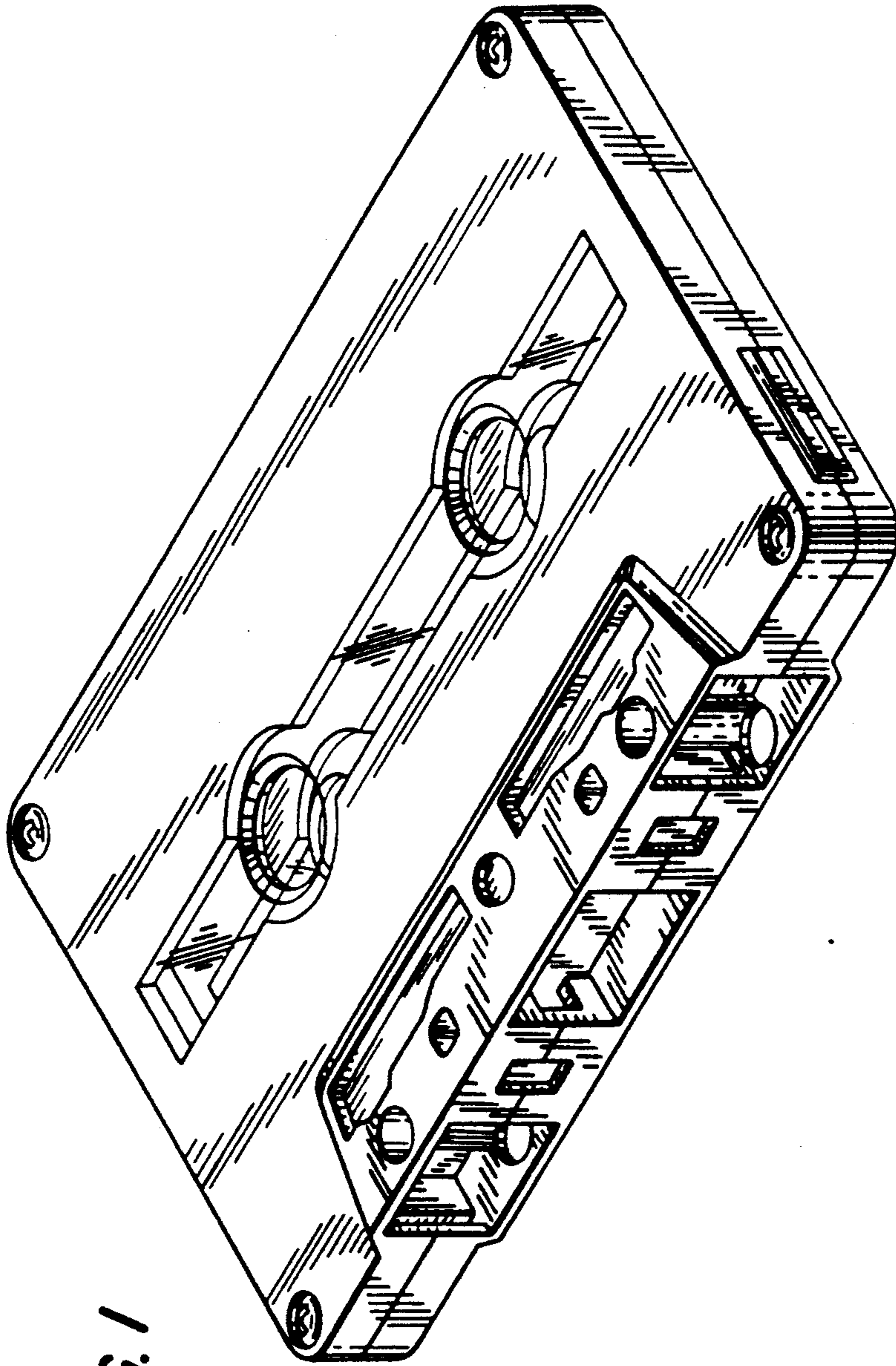

FIG. 1

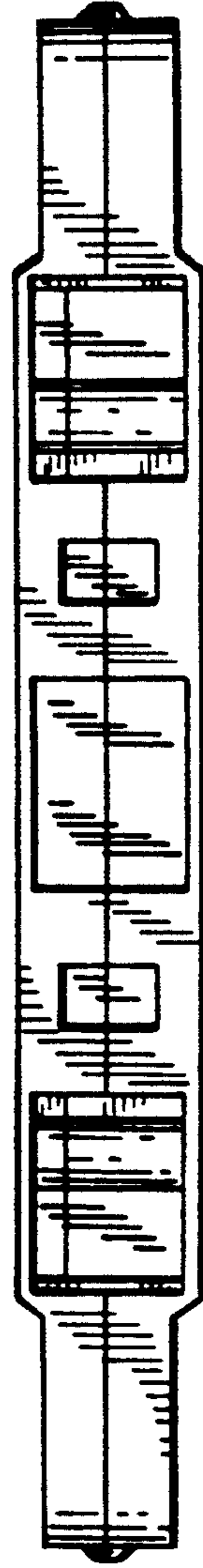
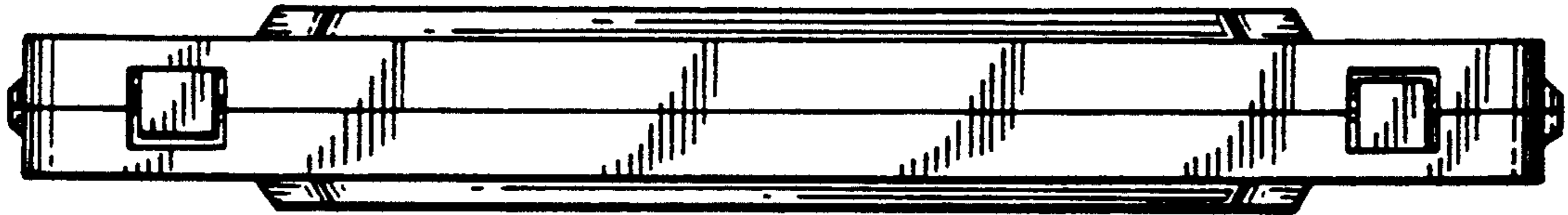
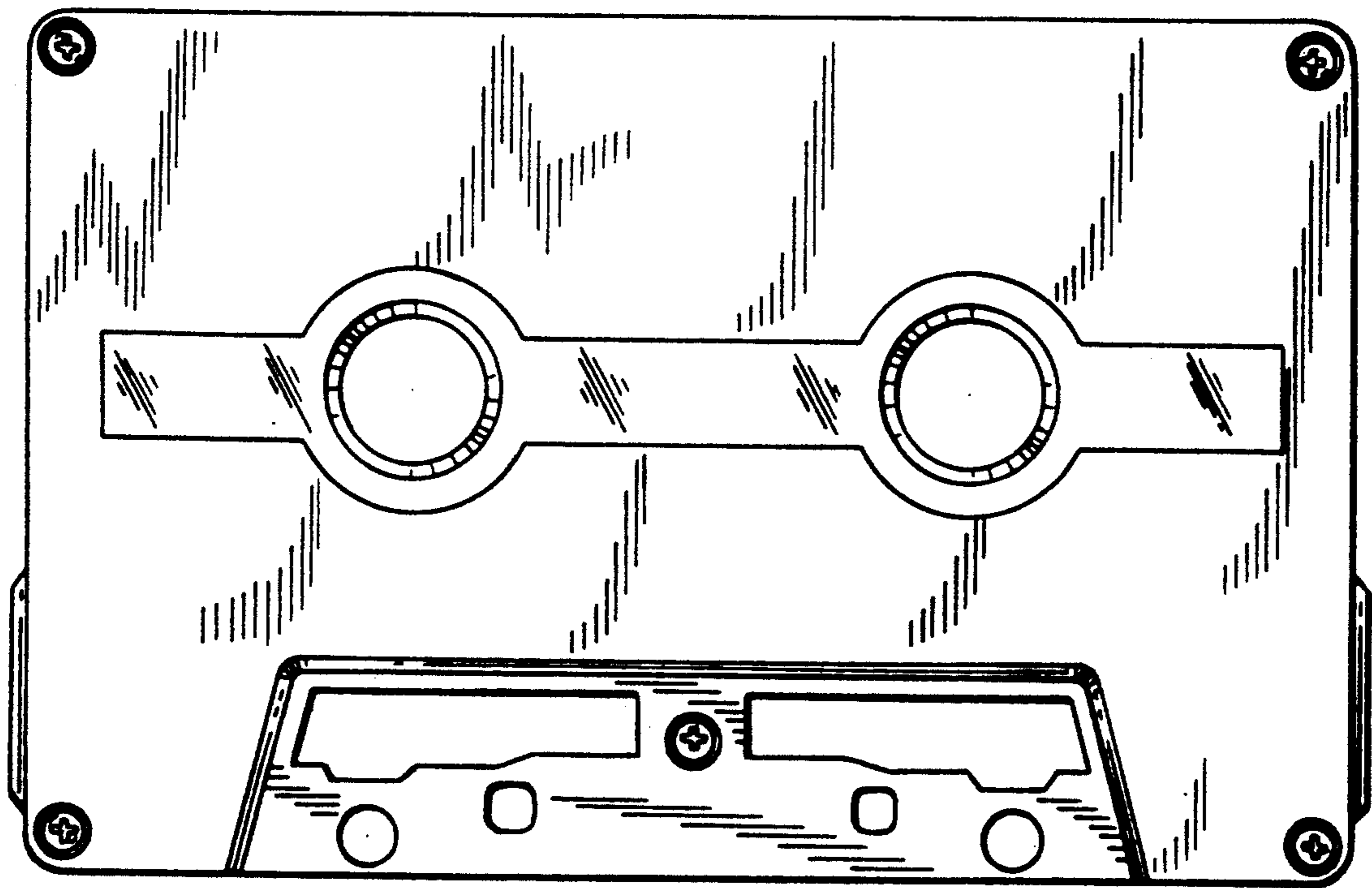

FIG. 2

*FIG. 3.*



*FIG. 5*



*FIG. 4*

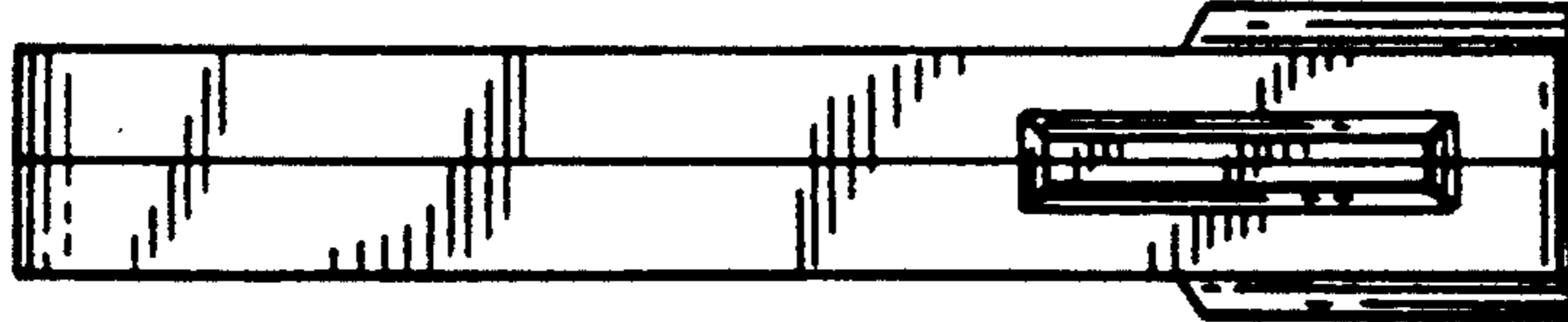

*FIG. 6*

