



US00D337311S

# United States Patent [19]

[11] Patent Number: **Des. 337,311**

Perzan et al.

[45] Date of Patent: **\*\* Jul. 13, 1993**

## [54] ELECTRIC SWITCH ENCLOSURE

[75] Inventors: **Denis A. Perzan**, Plainville; **Peter F. Cavanaugh**, W. Simsbury, both of Conn.

[73] Assignee: **General Electric Company**, New York, N.Y.

[\*\*] Term: **14 Years**

[21] Appl. No.: **828,581**

[22] Filed: **Jan. 24, 1992**

[52] U.S. Cl. .... **D13/160; D13/184**

[58] Field of Search ..... **D13/152, 184, 160; 361/331, 356, 357, 376; 200/50 A; 220/3.8**

## [56] References Cited

### U.S. PATENT DOCUMENTS

2,555,331	6/1951	Grady .....	D13/160 X
2,883,288	4/1959	Roberts, Jr. ....	220/3.8 X
3,879,589	4/1975	Rys .....	220/50 A
4,194,100	3/1980	Cox et al. ....	200/50 A

### FOREIGN PATENT DOCUMENTS

0636533	4/1928	France .....	200/50 A
---------	--------	--------------	----------

## OTHER PUBLICATIONS

Control panel enclosures 1 and 2 on p. 7 of *BOSS Contractors' Price Sheet Mar. 1, 1963*.

Safety switches on p. 25 of 1984 Square D Company catalog.

NEMA switch enclosures on p. 363 of *Westinghouse Catalog 55-000*, copyright Mar. 1989.

*Primary Examiner*—Wallace R. Burke

*Assistant Examiner*—Joel Sincavage

*Attorney, Agent, or Firm*—Richard A. Menelly

## [57] CLAIM

The ornamental design for an electric switch enclosure, as shown and described.

## DESCRIPTION

FIG. 1 is a top perspective view of an electric switch enclosure showing our new design;

FIG. 2 is a left side view thereof;

FIG. 3 is a right side view;

FIG. 4 is a left end view thereof;

FIG. 5 is a right end view;

FIG. 6 is a bottom plan view thereof; and,

FIG. 7 is a top plan view thereof.

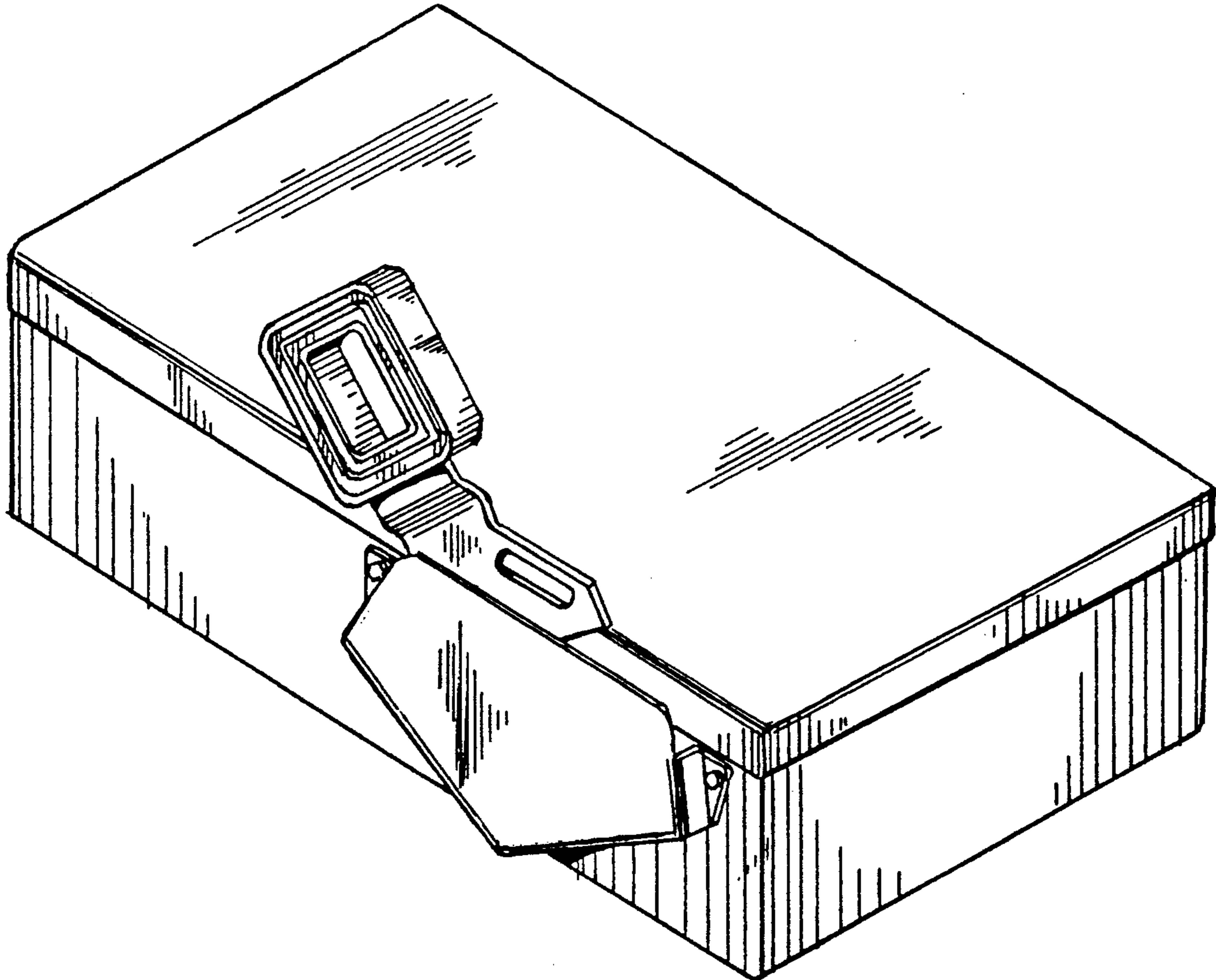

FIG. 1

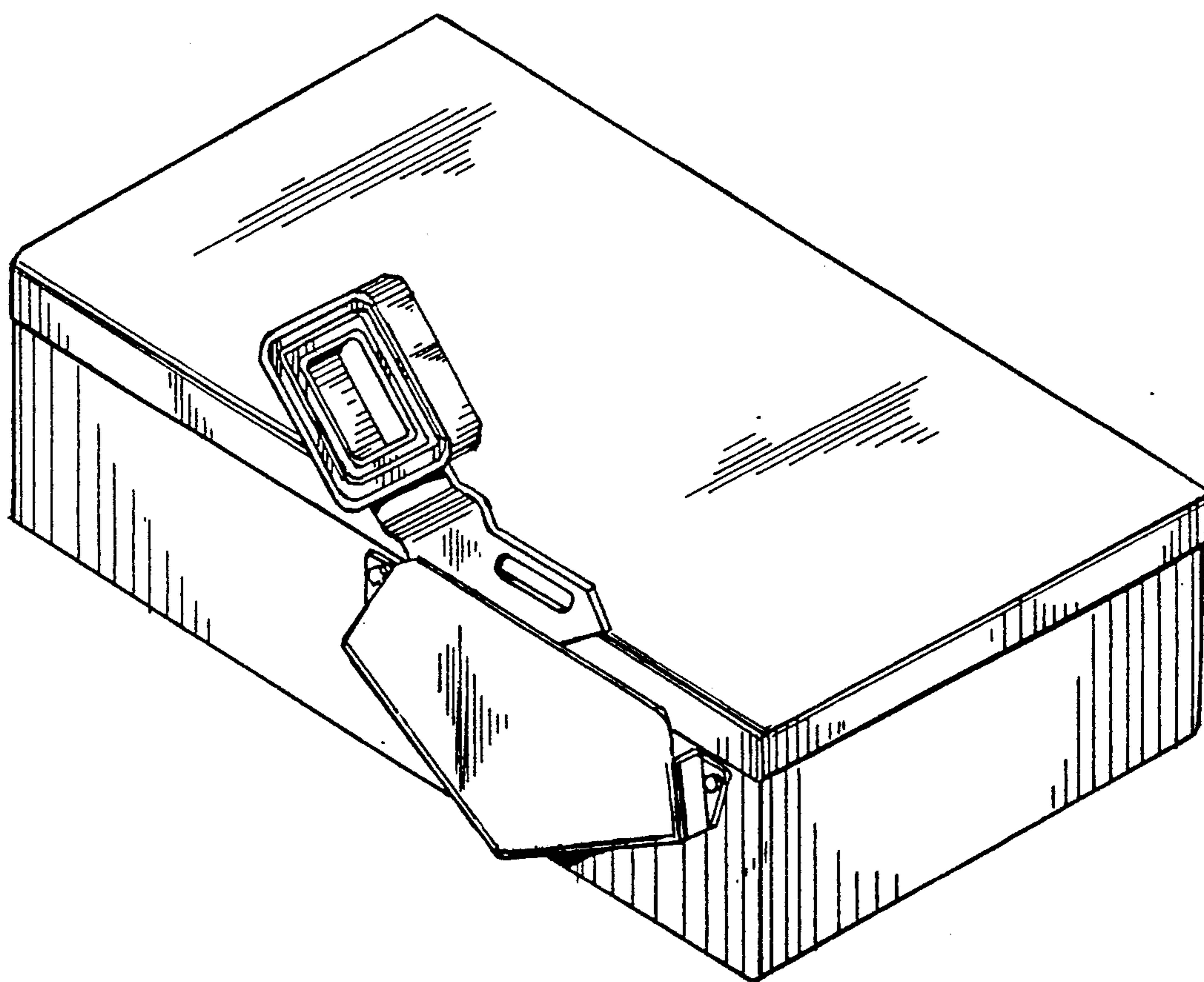

FIG. 2

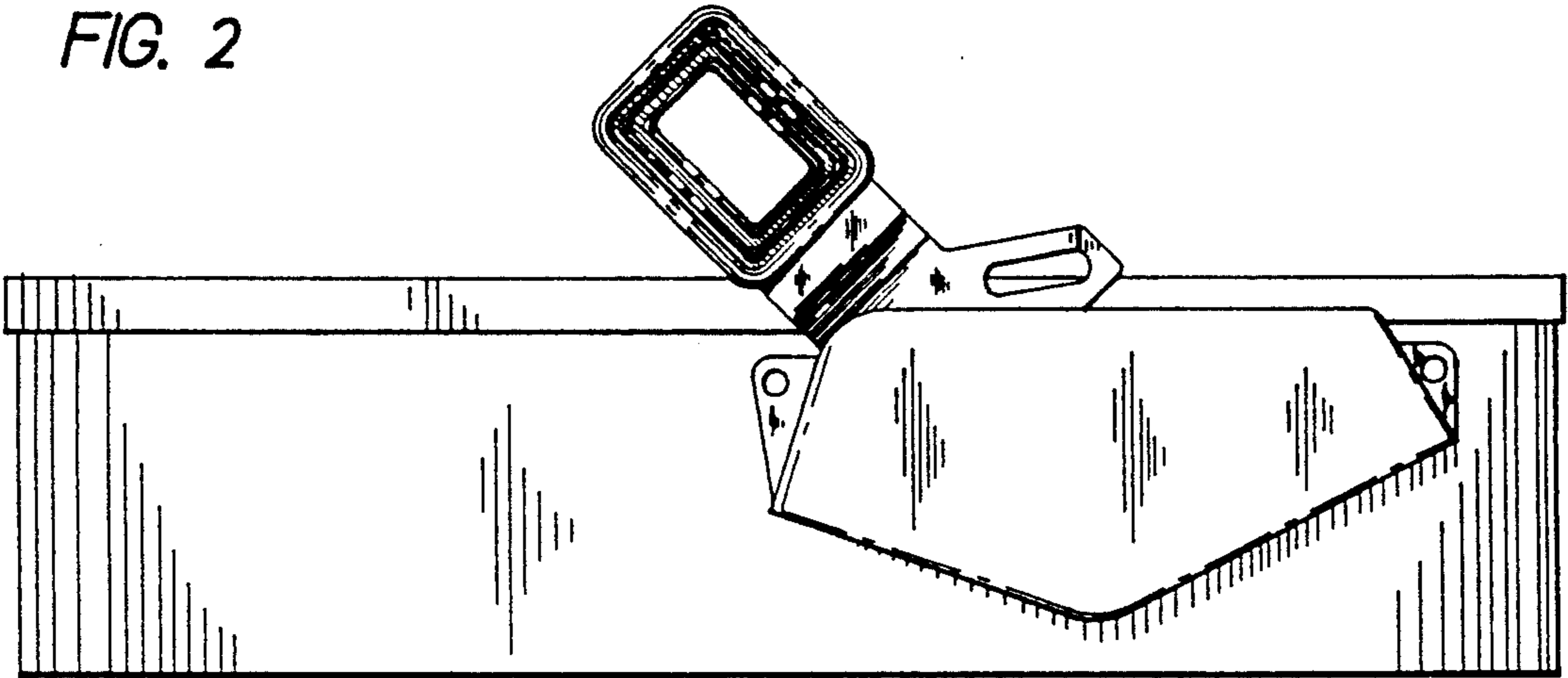

FIG. 3

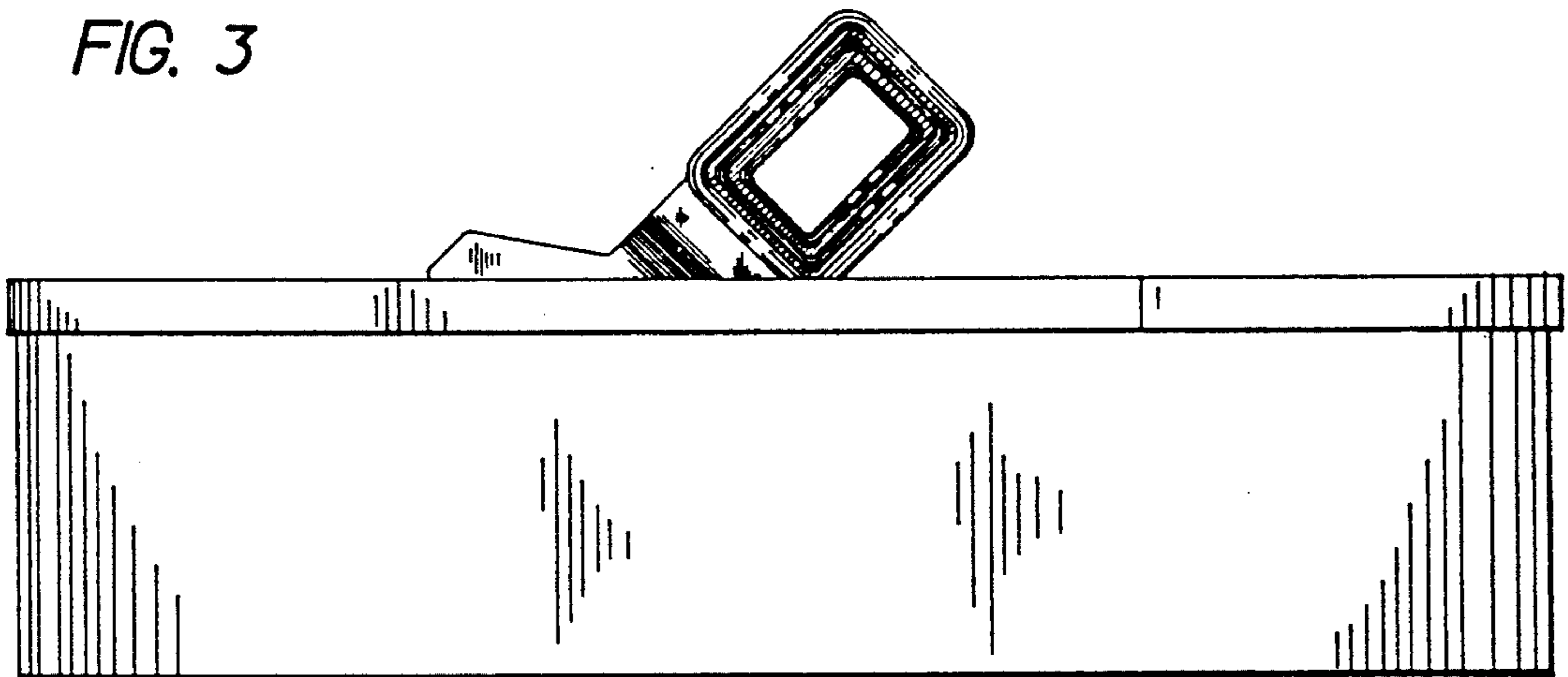

FIG. 4

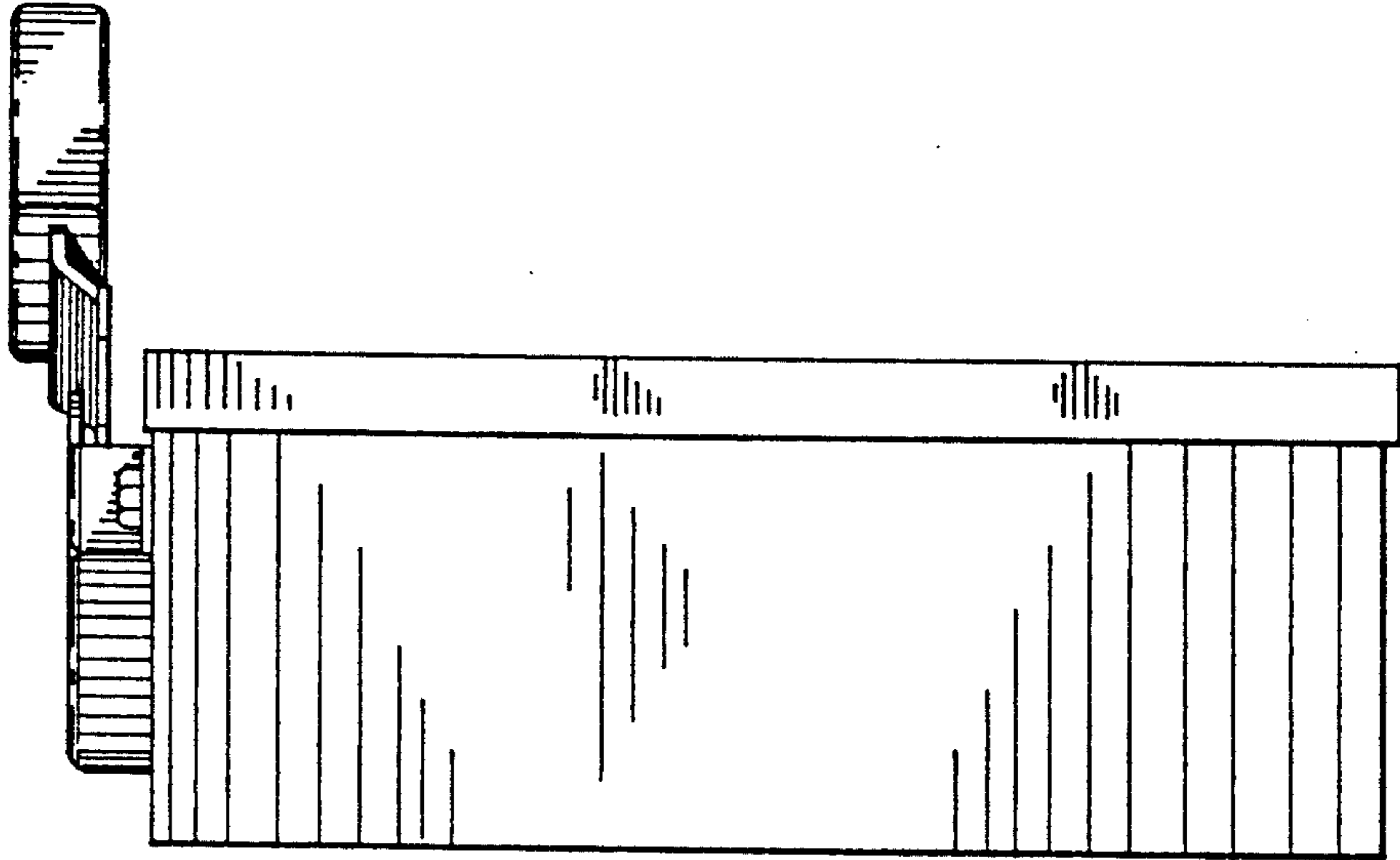

FIG. 5

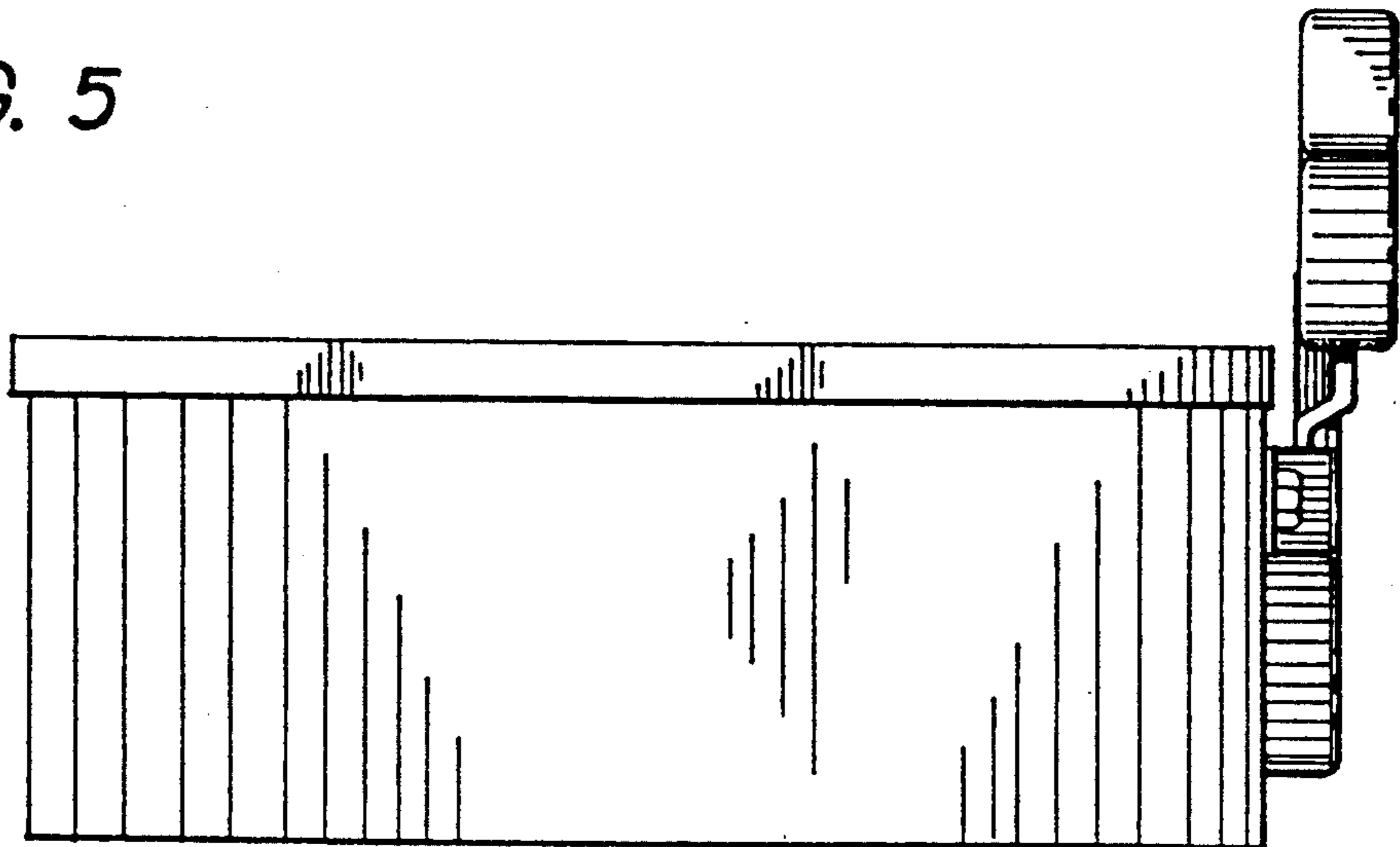

FIG. 6

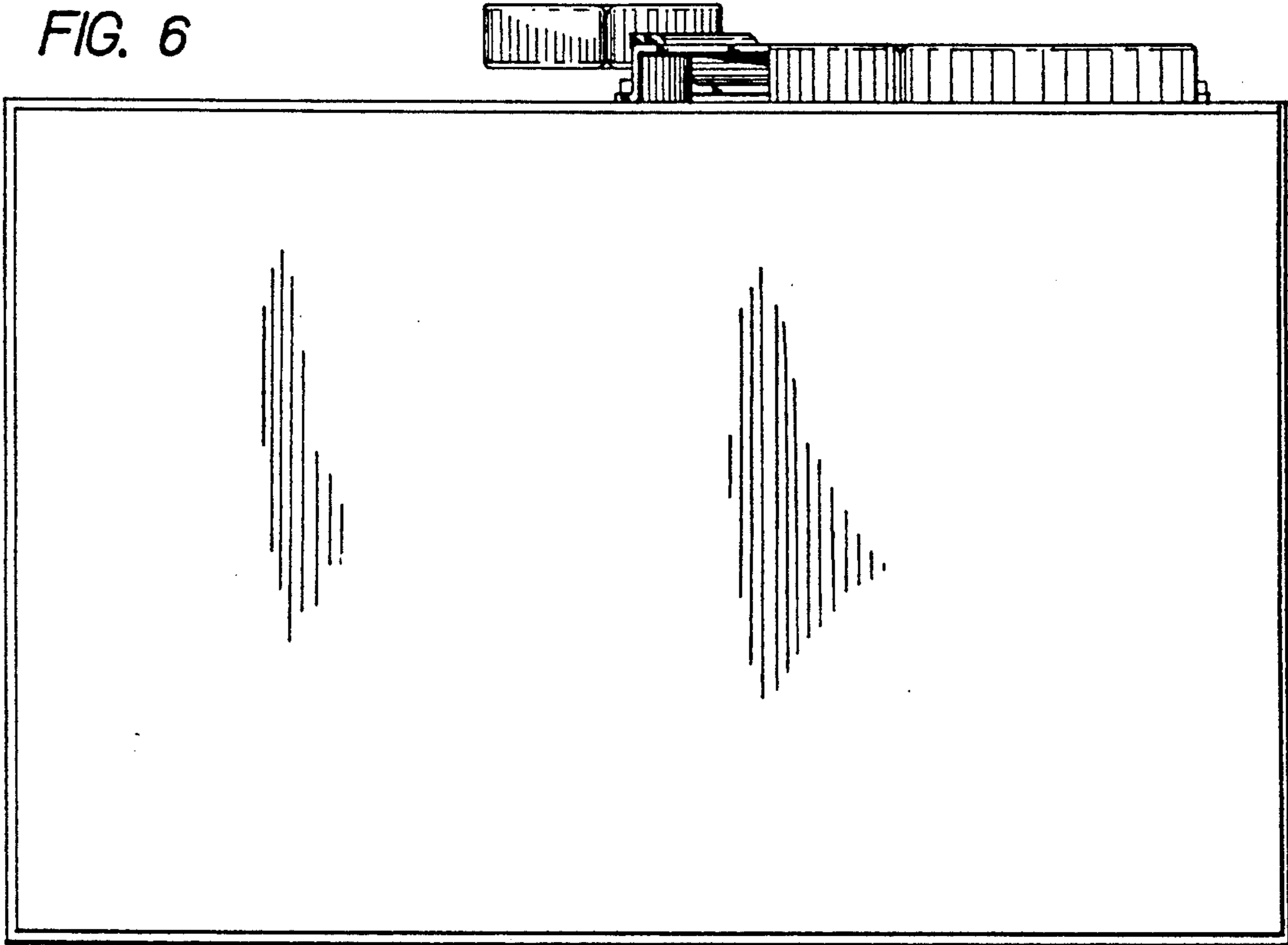

FIG. 7

