



US00D337301S

United States Patent [19] Hill

[11] Patent Number: **Des. 337,301**

[45] Date of Patent: **** Jul. 13, 1993**

[54] HELICOPTER GUNSHIP

[76] Inventor: **Jamie R. Hill**, 1325 SE. Fourth St.,
Cape Coral, Fla. 33904

[**] Term: **14 Years**

[21] Appl. No.: **767,918**

[22] Filed: **Sep. 30, 1991**

[52] U.S. Cl. **D12/327**

[58] Field of Search **D12/319, 326, 327, 328,**
D12/329; 244/17.11, 17.19, 17.21

[56] **References Cited**
PUBLICATIONS

Jane's all the World's aircraft, 1983-84, p. 324 USA
aircraft, Bell Model "222A" Twin-turbine light Com-
mercial helicopter.
Interavra, Jun. 1981, Italian Army A.129, (upper).

Flight Int'l, Sep. 10, 1983, Hughes "AH-64A Apache".

Primary Examiner—Kay H. Chin
Attorney, Agent, or Firm—Frank Lukasik

[57] **CLAIM**

The ornamental design for a helicopter sunship, as
shown and described.

DESCRIPTION

FIG. 1 is a top and front perspective view of a helicop-
ter gunship showing my new design, one of the rotor
blades is shown broken away for convenience of illus-
tration;

FIG. 2 is a front elevational view thereof;

FIG. 3 is a side elevational view thereof, the opposite
side elevational view being a mirror image of that
shown;

FIG. 4 is a top plan view thereof; and,

FIG. 5 is a bottom plan view thereof.

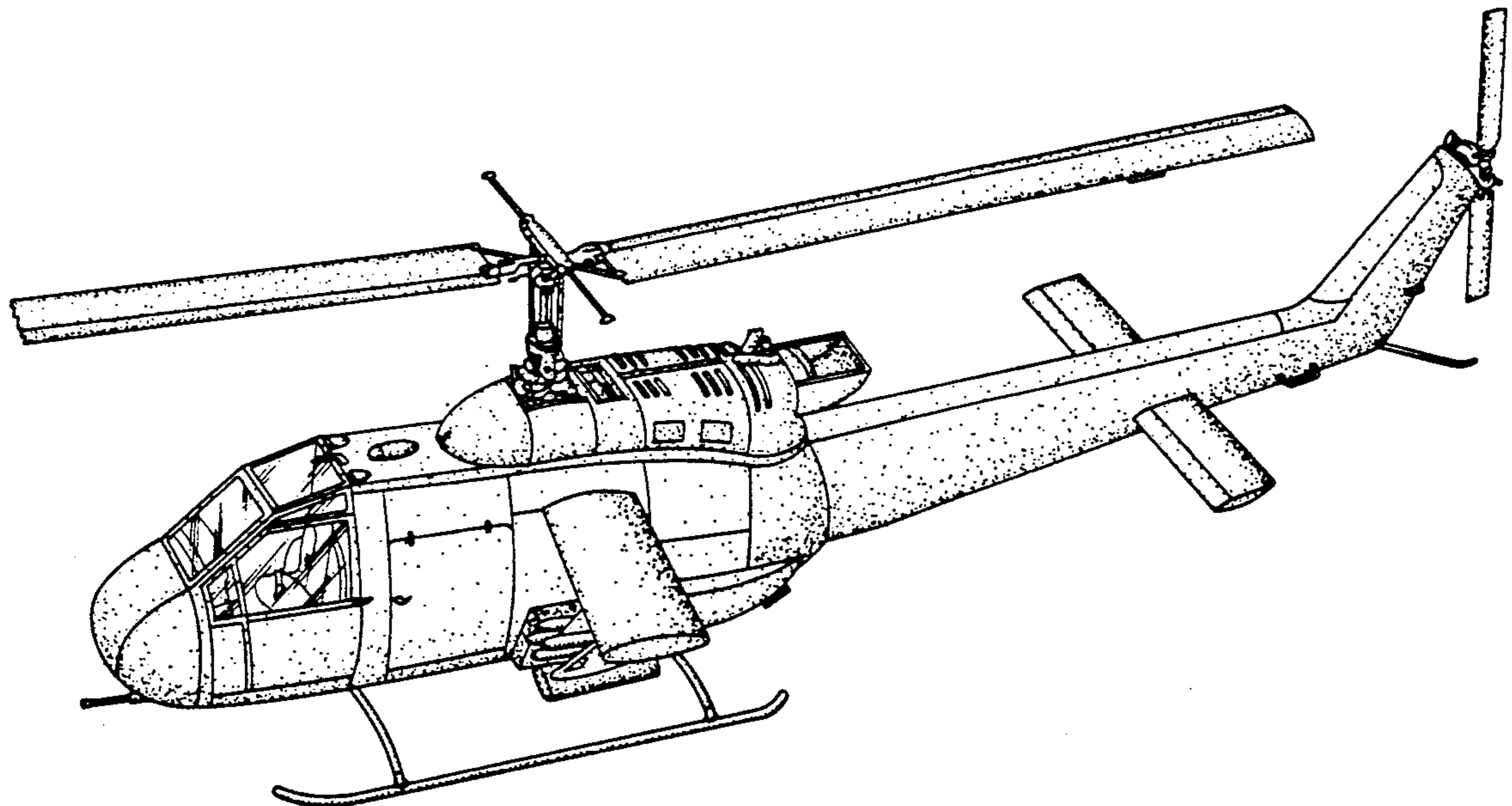

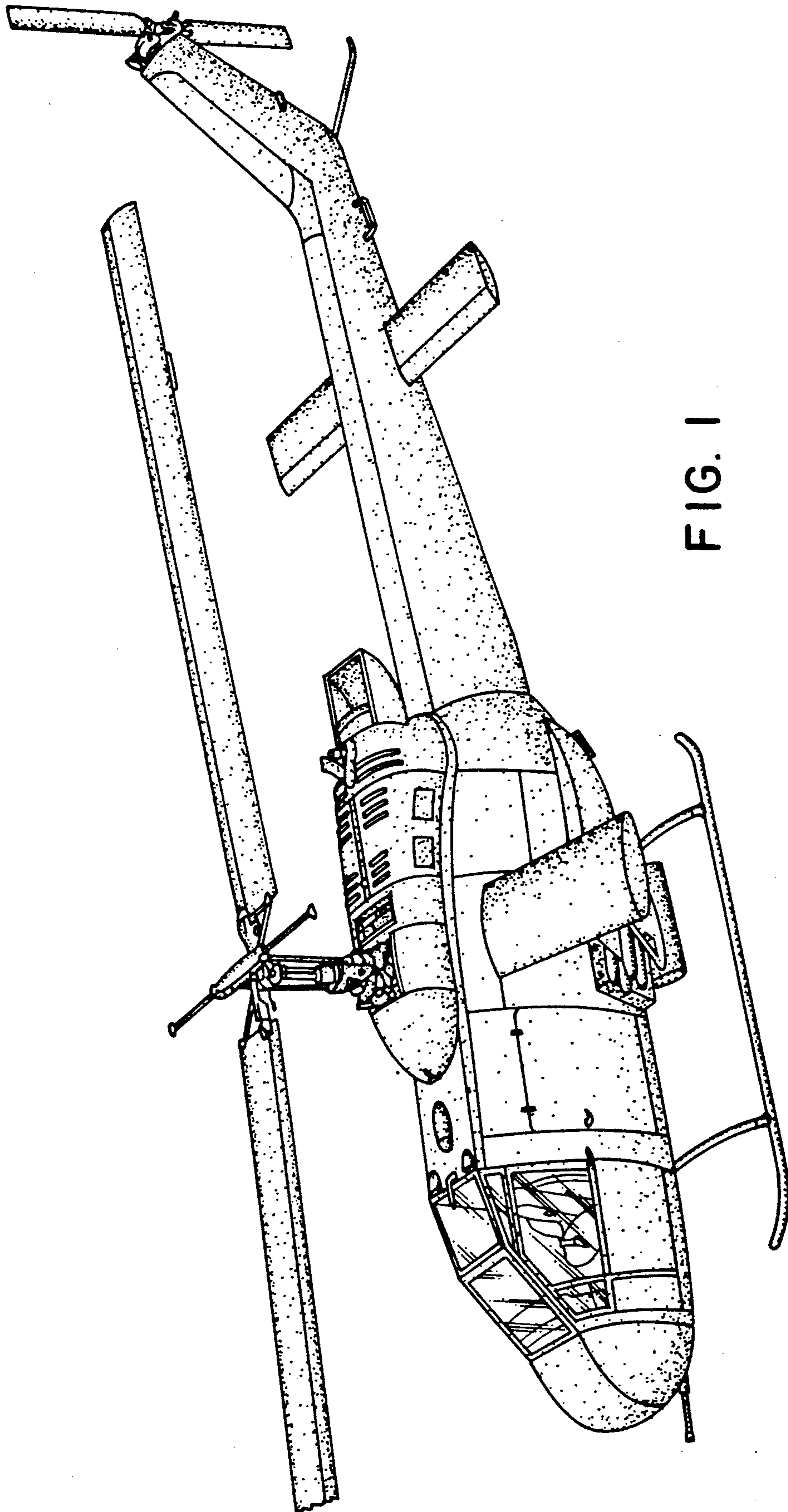

FIG. 1

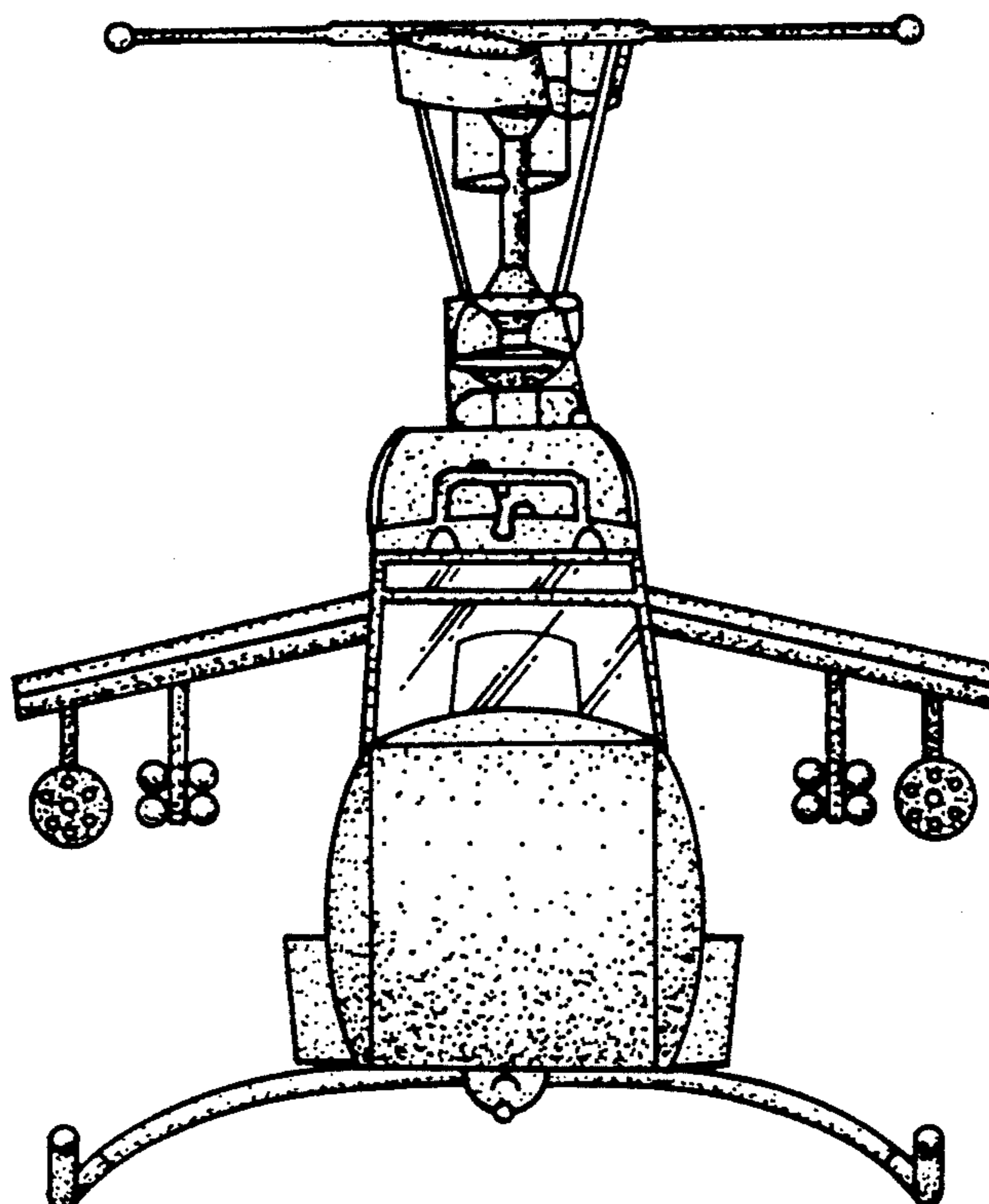

FIG. 2

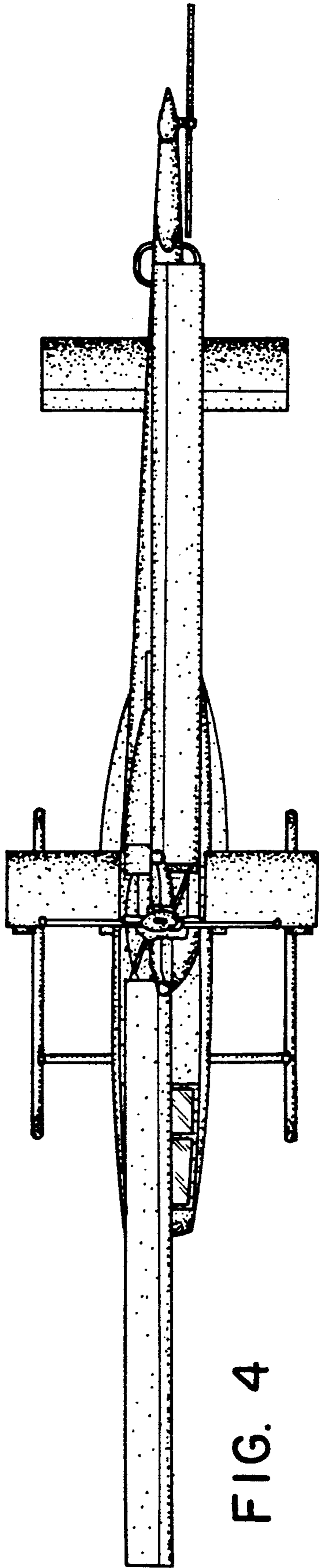

FIG. 4

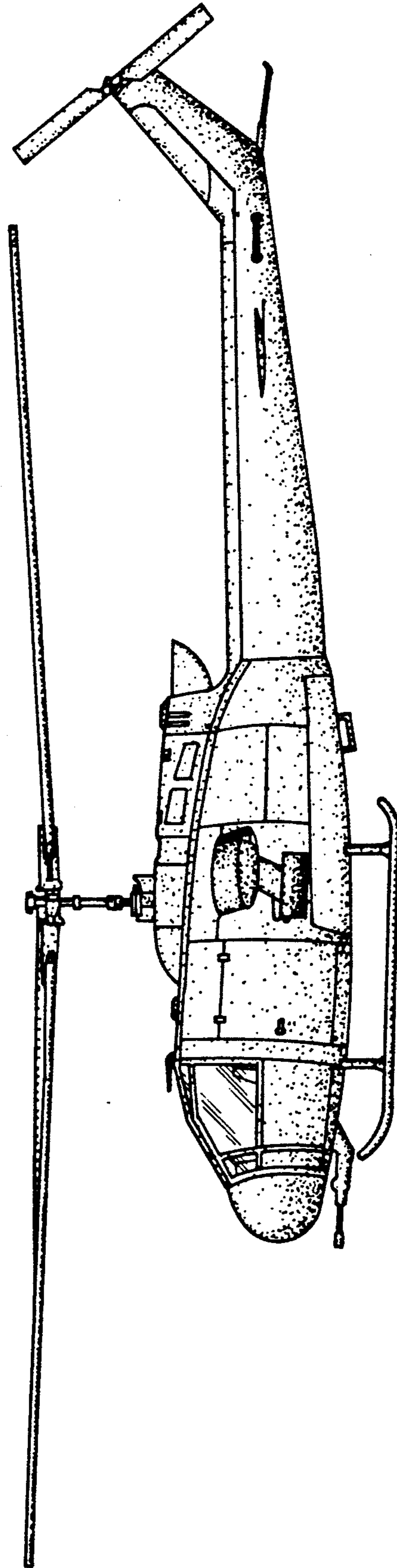

FIG. 3

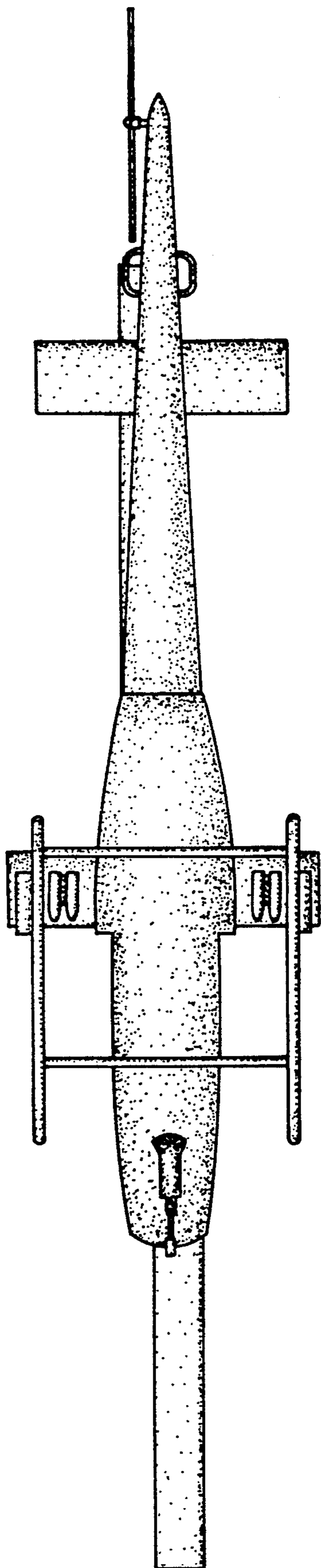

FIG. 5