



US00D337300S

United States Patent [19]
Bielefeldt

[11] **Patent Number: Des. 337,300**

[45] **Date of Patent: ** Jul. 13, 1993**

[54] **WING TYPE SAILING YACHT**

[75] **Inventor: Ernst-August Bielefeldt, Hollenstedt, Fed. Rep. of Germany**

[73] **Assignee: Deutsche Airbus GmbH, Hamburg, Fed. Rep. of Germany**

[**] **Term: 14 Years**

[21] **Appl. No.: 643,651**

[22] **Filed: Jan. 15, 1991**

Related U.S. Application Data

[63] **Continuation of Ser. No. 407,550, Sep. 15, 1989, Pat. No. 5,063,869.**

[30] **Foreign Application Priority Data**

Sep. 16, 1988 [DE] Fed. Rep. of Germany 3831468.1

[52] **U.S. Cl. D12/303; D12/304**

[58] **Field of Search D12/303, 304, 300; 114/61, 56, 274, 280, 281, 271, 292, 39.1**

[56] **References Cited**

U.S. PATENT DOCUMENTS

3,802,366 4/1974 Mankwtch 114/39
3,964,417 6/1976 Williams et al. 114/283
4,771,716 9/1988 Dat D12/304

Primary Examiner—Kay H. Chin

Attorney, Agent, or Firm—W. G. Fasse; D. H. Kane, Jr.

[57] **CLAIM**

The ornamental design for a wing type sailing yacht, as shown and described.

DESCRIPTION

FIG. 1 is a top and side perspective view of a wing type sailing yacht showing my new design;

FIG. 2 is a side elevational view thereof, the opposite side elevational view being a mirror image of that shown;

FIG. 3 is a front elevational view thereof;

FIG. 4 is a top plan view thereof;

FIG. 5 is a front elevational view of a second embodiment of the wing type sailing yacht;

FIG. 6 is a bottom plan view of FIGS. 1 and 5; and,

FIG. 7 is a rear elevational view of FIG. 5.

The sole difference between the first embodiment and second embodiment being in that the first embodiment have ribs on the mast.

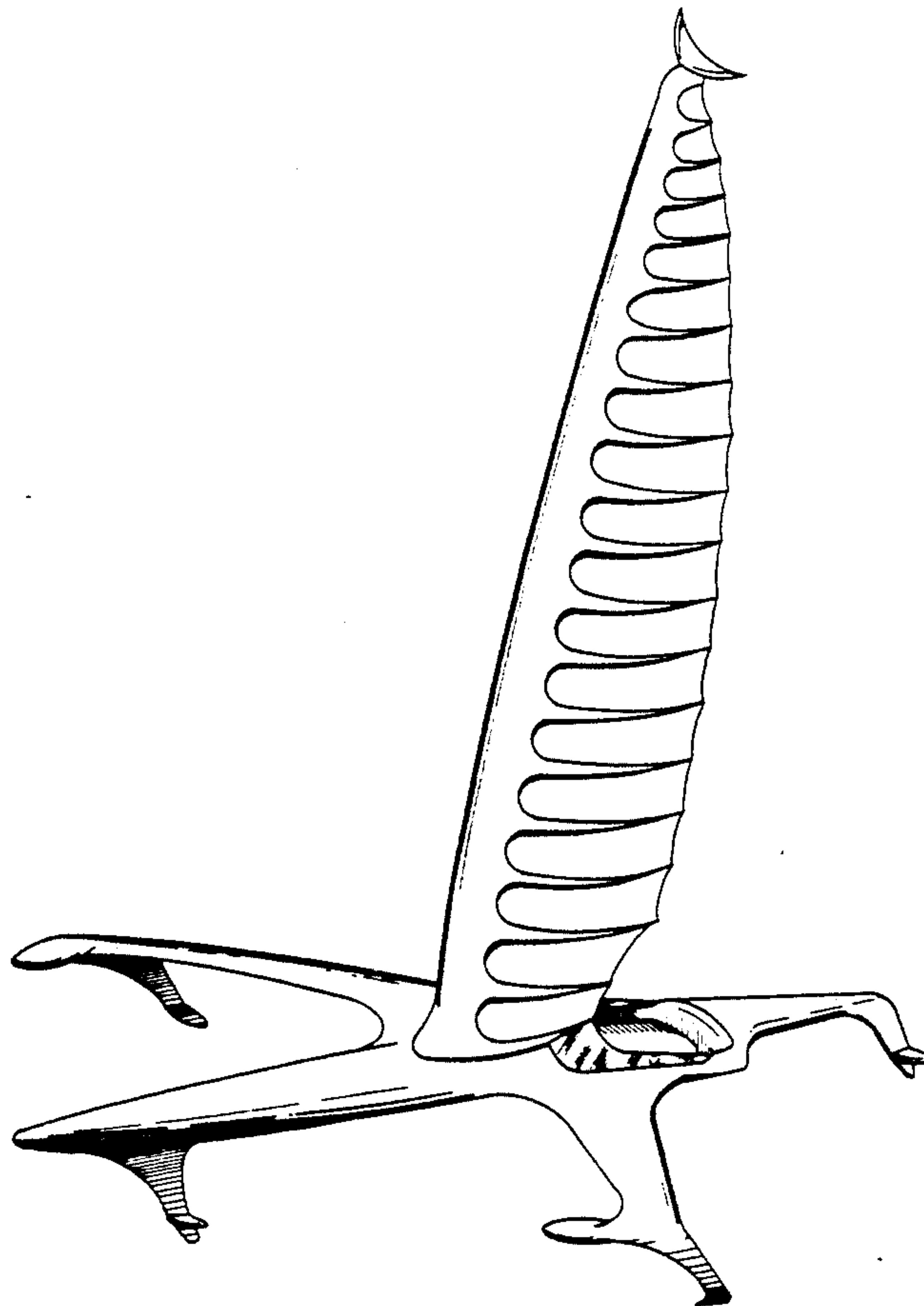

FIG. 1

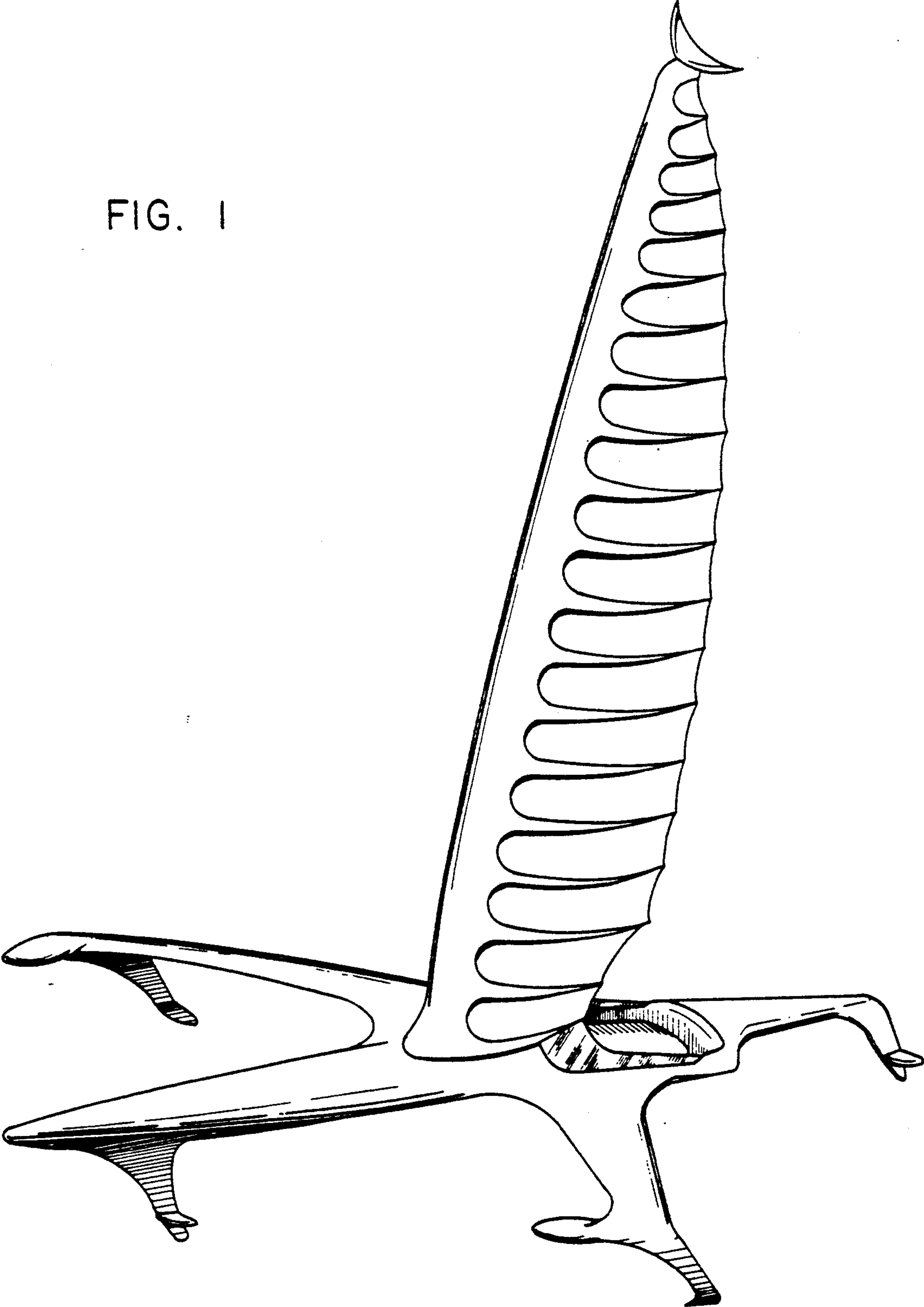

FIG. 2

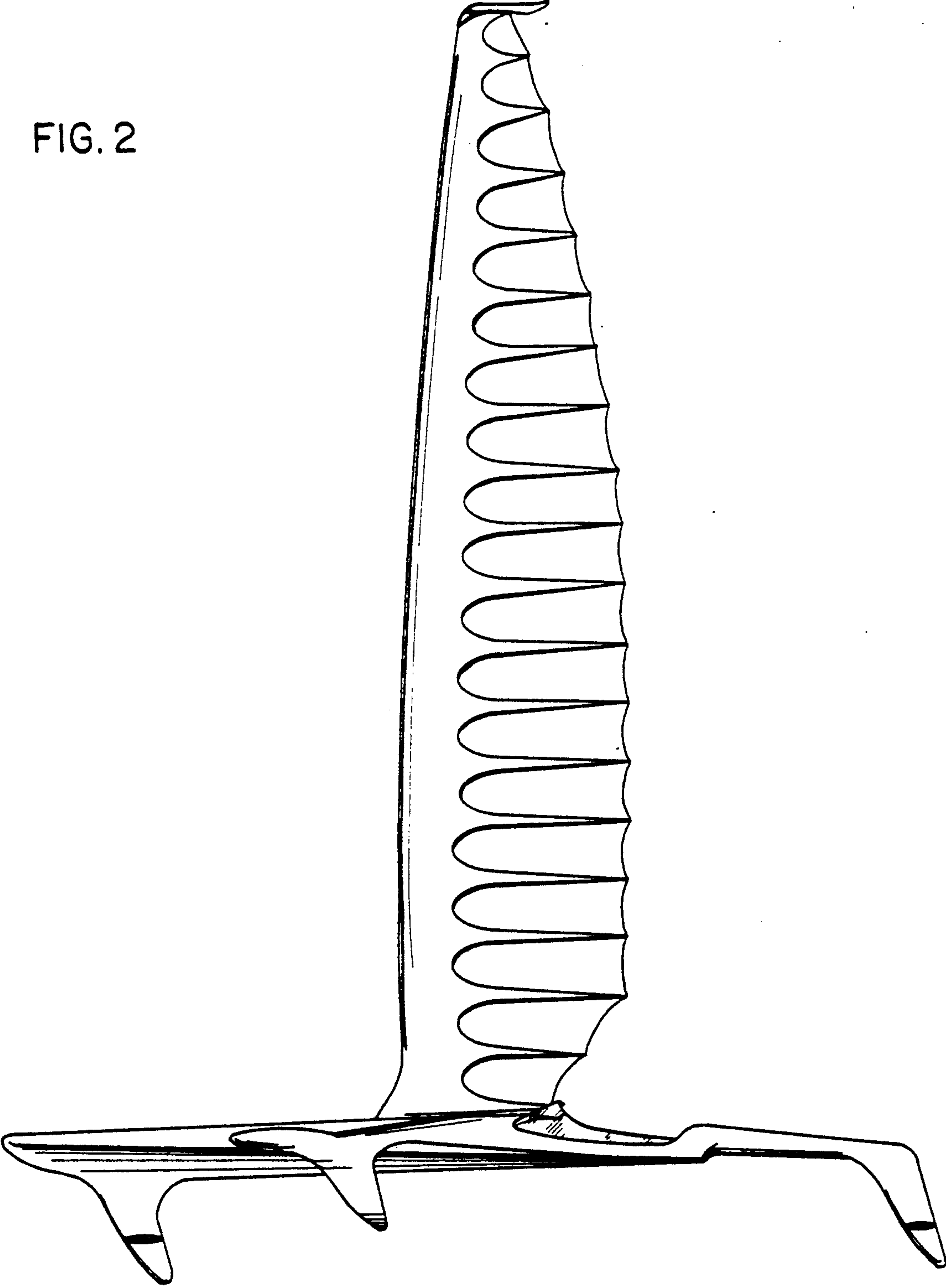
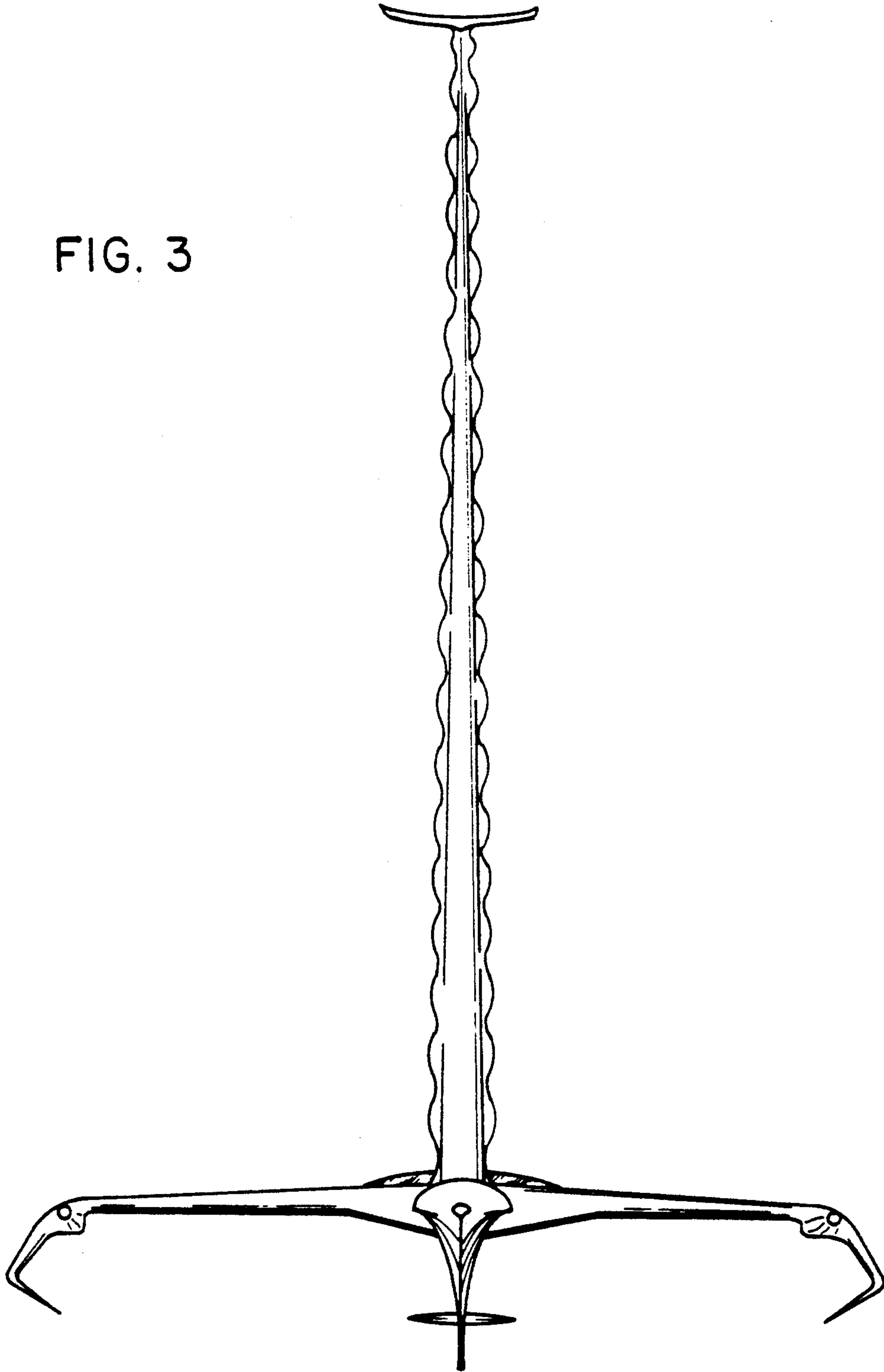

FIG. 3



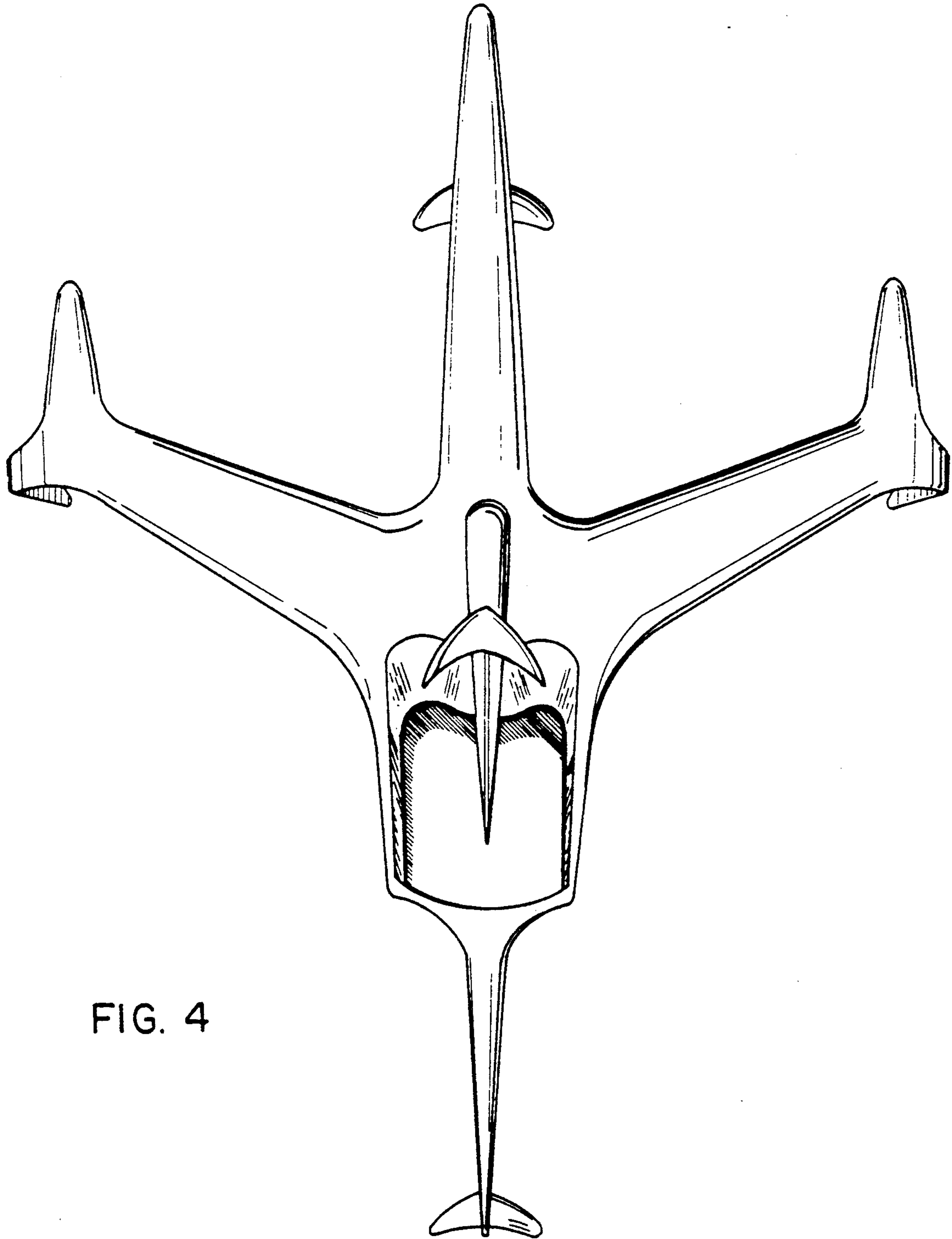
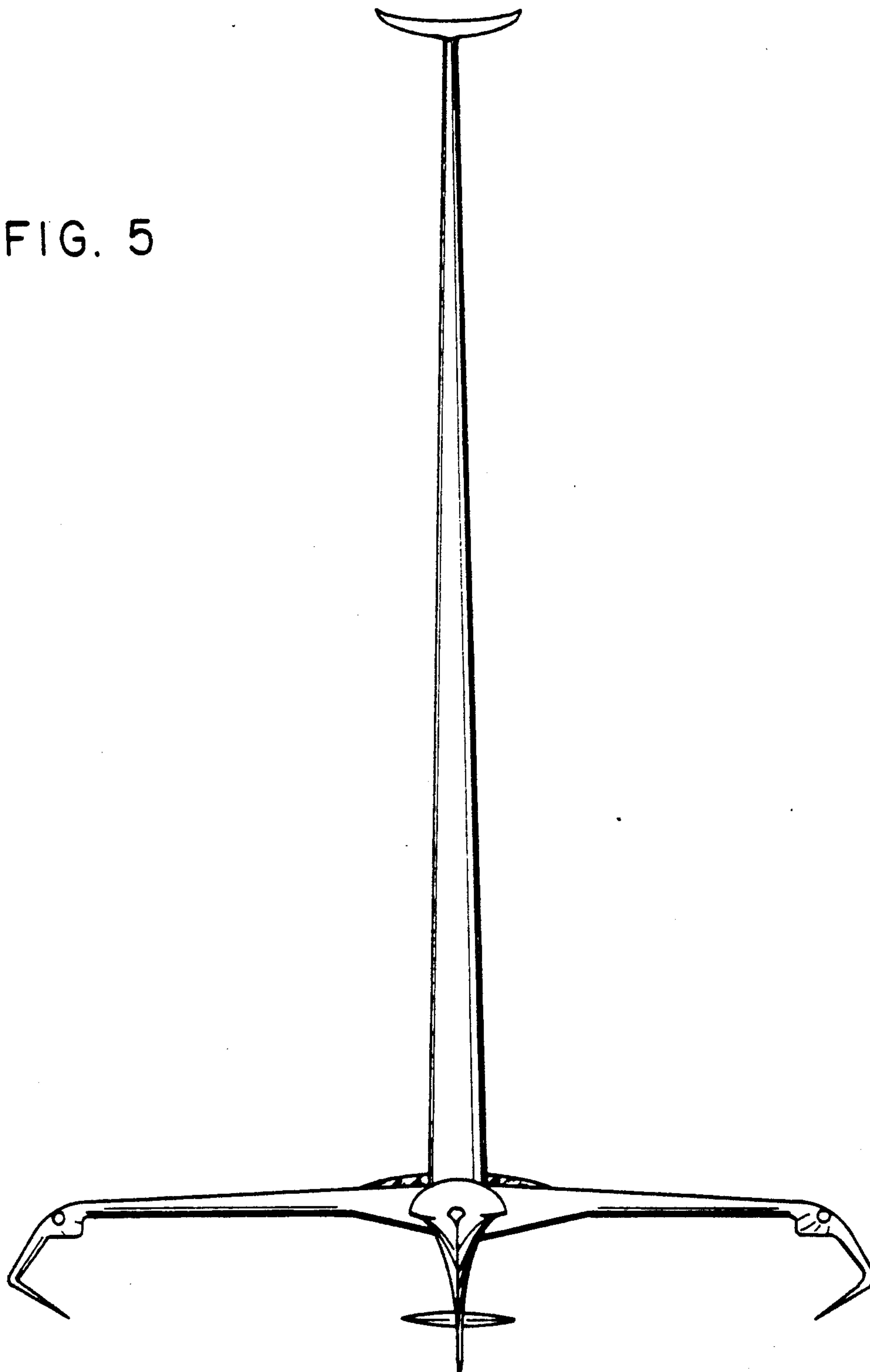

FIG. 4

FIG. 5



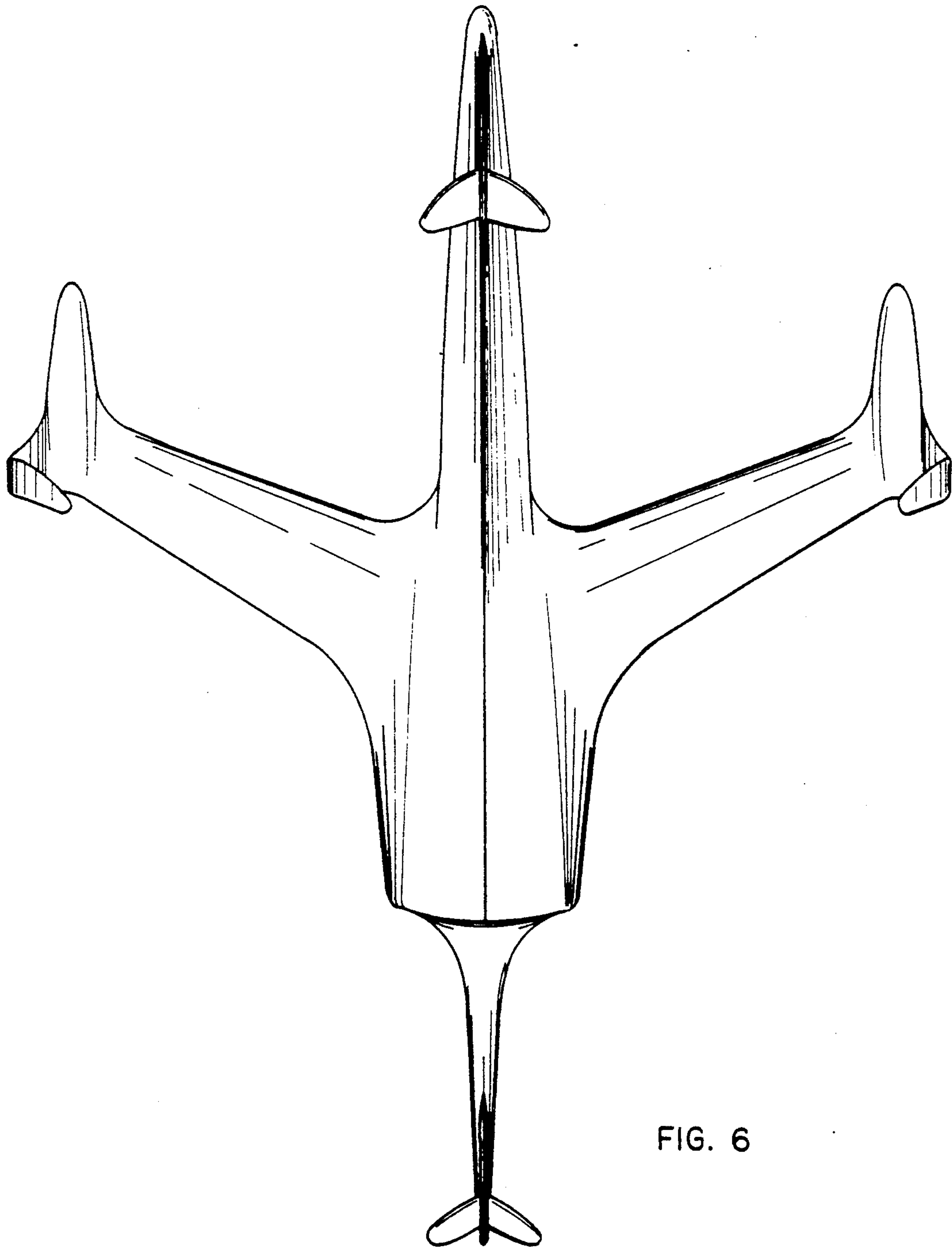

FIG. 6

FIG. 7

