



US00D337121S

United States Patent [19]

[11] Patent Number: **Des. 337,121**

Torrey

[45] Date of Patent: **** Jul. 6, 1993**

[54] **STEERABLE TANDEM RAKE HITCH**

4,478,032	10/1984	Inskip	172/679
4,500,105	2/1985	Machnee	280/463
5,025,616	6/1991	Moss	56/384

[76] Inventor: **Steven Torrey, R.D. 1, Vergennes, Vt. 05491**

Primary Examiner—Bernard Ansher
Assistant Examiner—Sandra Morris
Attorney, Agent, or Firm—Terry M. Gernstein

[**] Term: **14 Years**

[21] Appl. No.: **702,736**

[57] **CLAIM**

[22] Filed: **May 20, 1991**

The ornamental design for a steerable tandem rake hitch, as shown and described.

[52] U.S. Cl. **D15/27**

[58] Field of Search **D15/10, 27; 56/15.9, 56/365-366, 377, 384, DIG. 21; 172/472, 679; 280/411 C, 412, 468**

DESCRIPTION

[56] **References Cited**

U.S. PATENT DOCUMENTS

FIG. 1 is a perspective view of the steerable tandem rake hitch showing my new design; FIG. 2 is a front end elevational view thereof; FIG. 3 is a rear end elevational view thereof; FIG. 4 is a right side elevational view thereof; FIG. 5 is a left side elevational view thereof; FIG. 6 is a top plan view thereof; and, FIG. 7 is a bottom view thereof.

3,523,699	8/1970	Sinkule .	
4,109,729	8/1978	Kaercher, Jr.	172/679
4,213,628	7/1980	Hardesty .	
4,262,921	4/1981	Dwyer .	

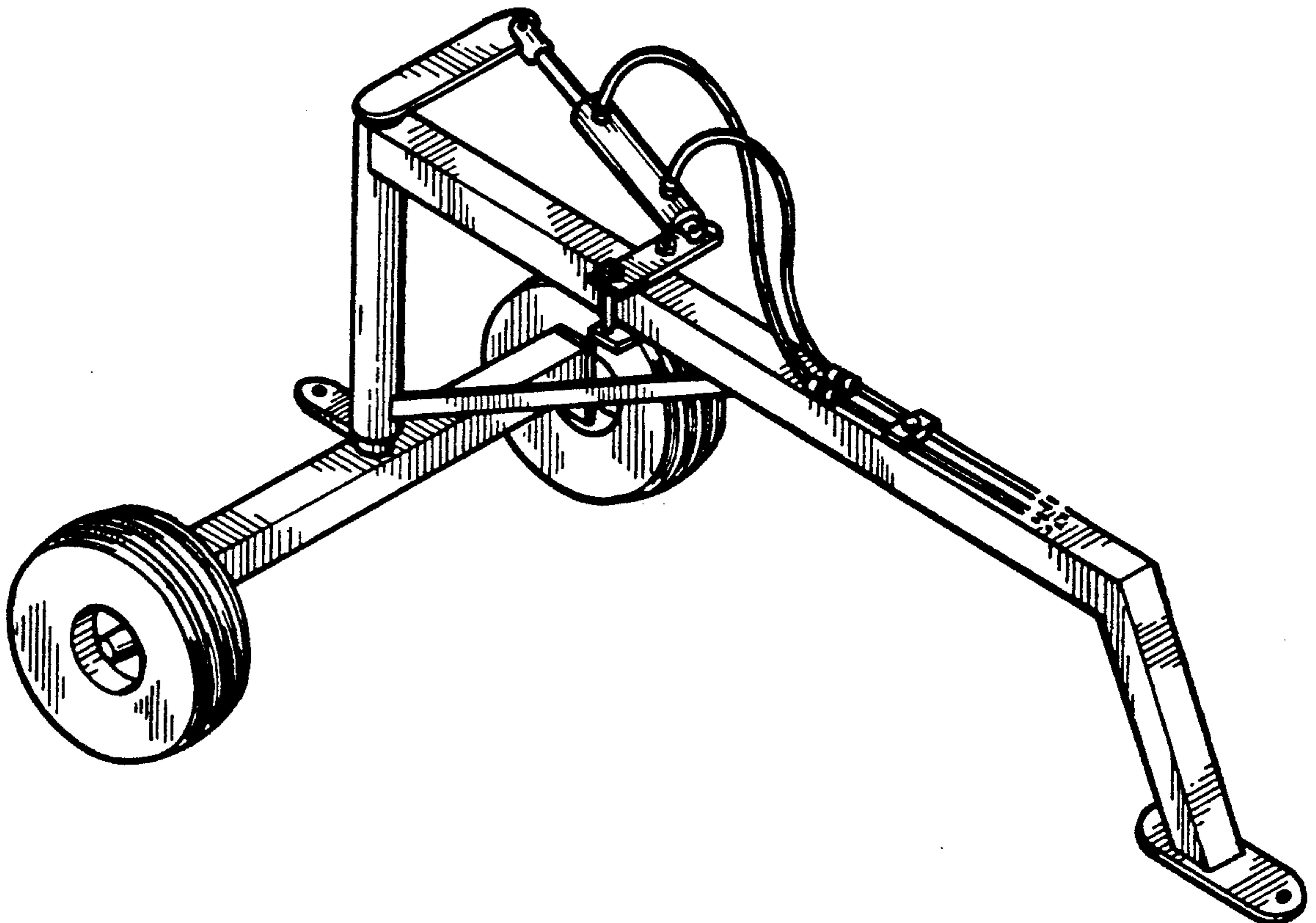
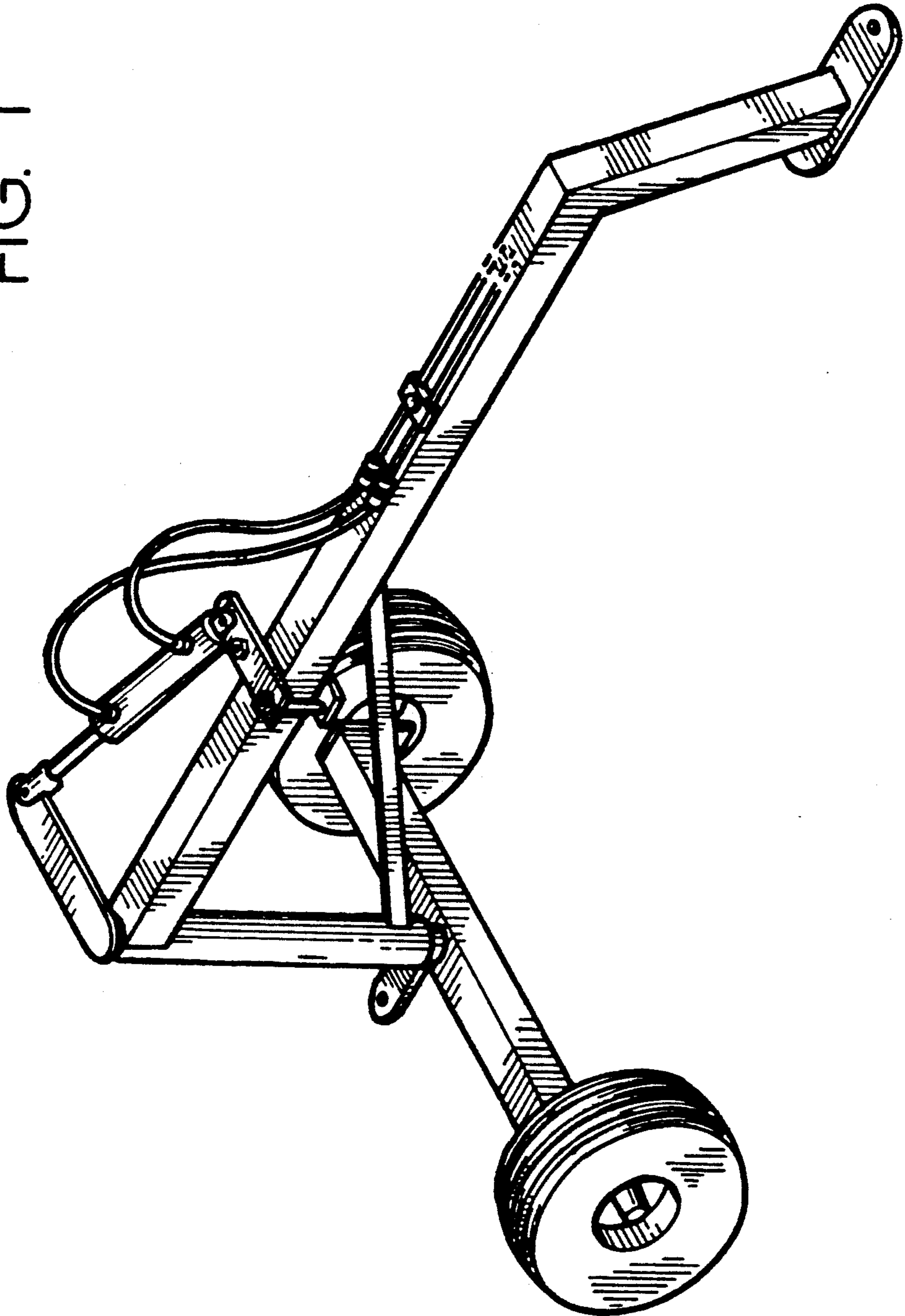

FIG. 1



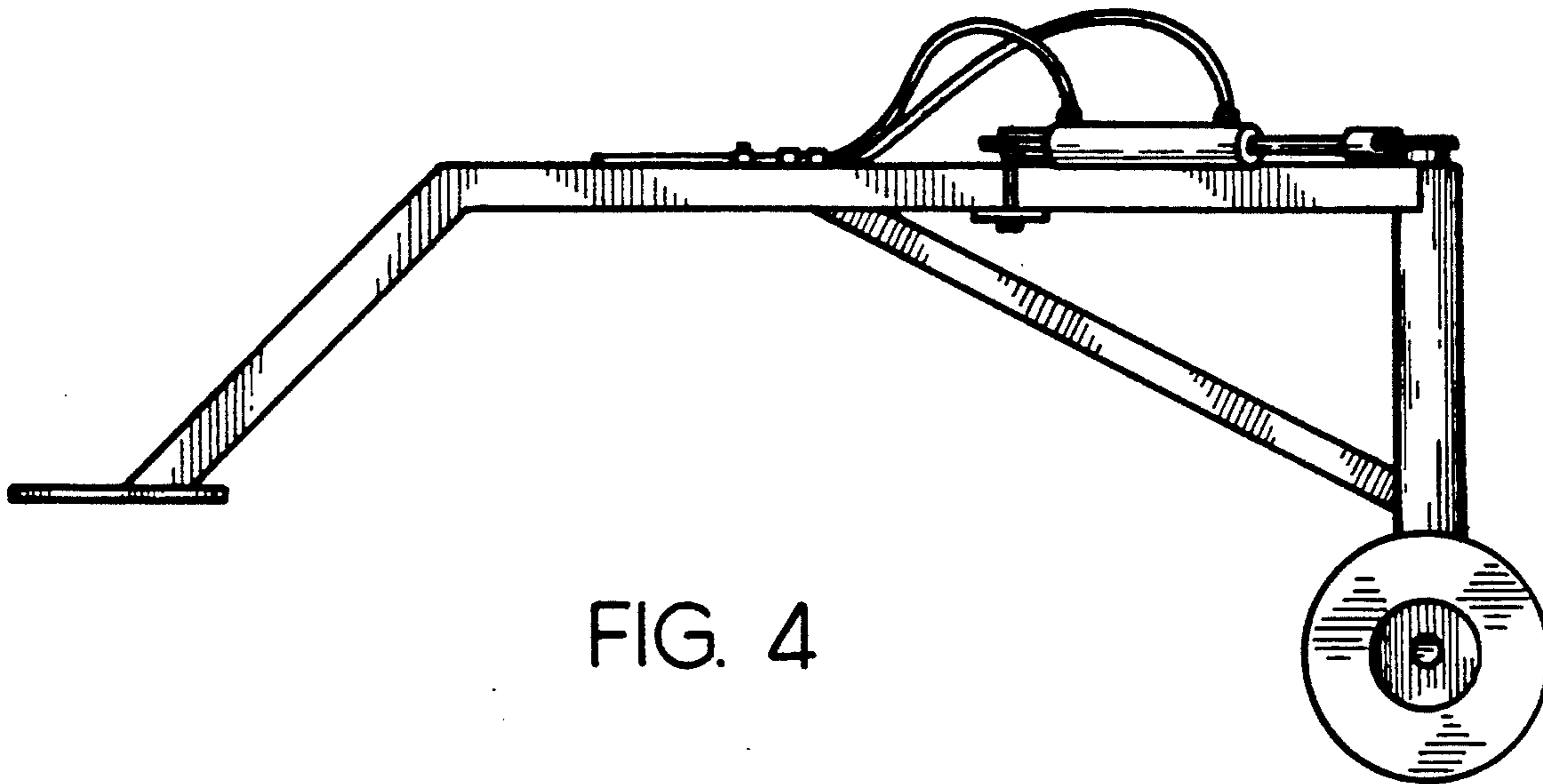

FIG. 4

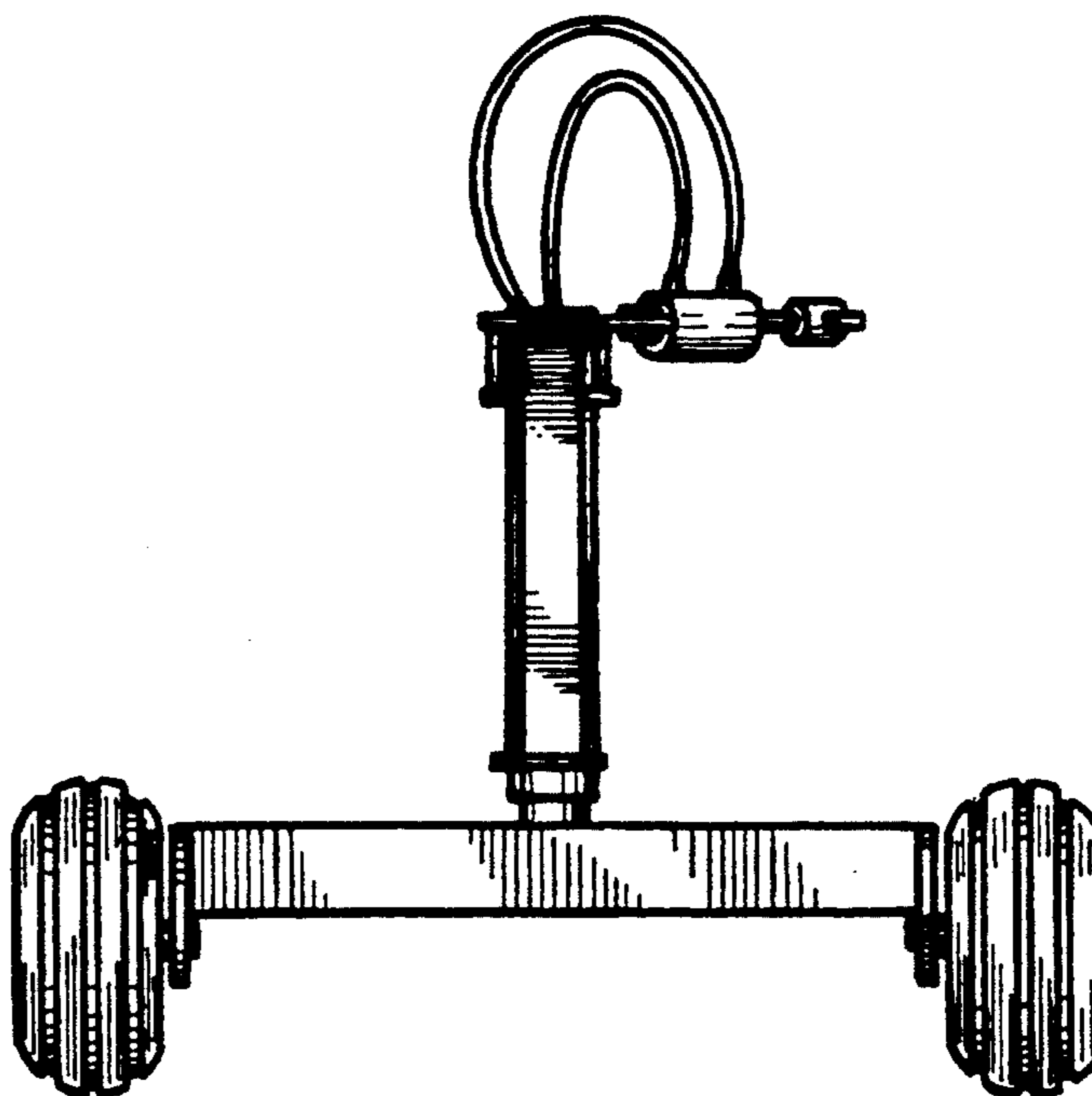

FIG. 2

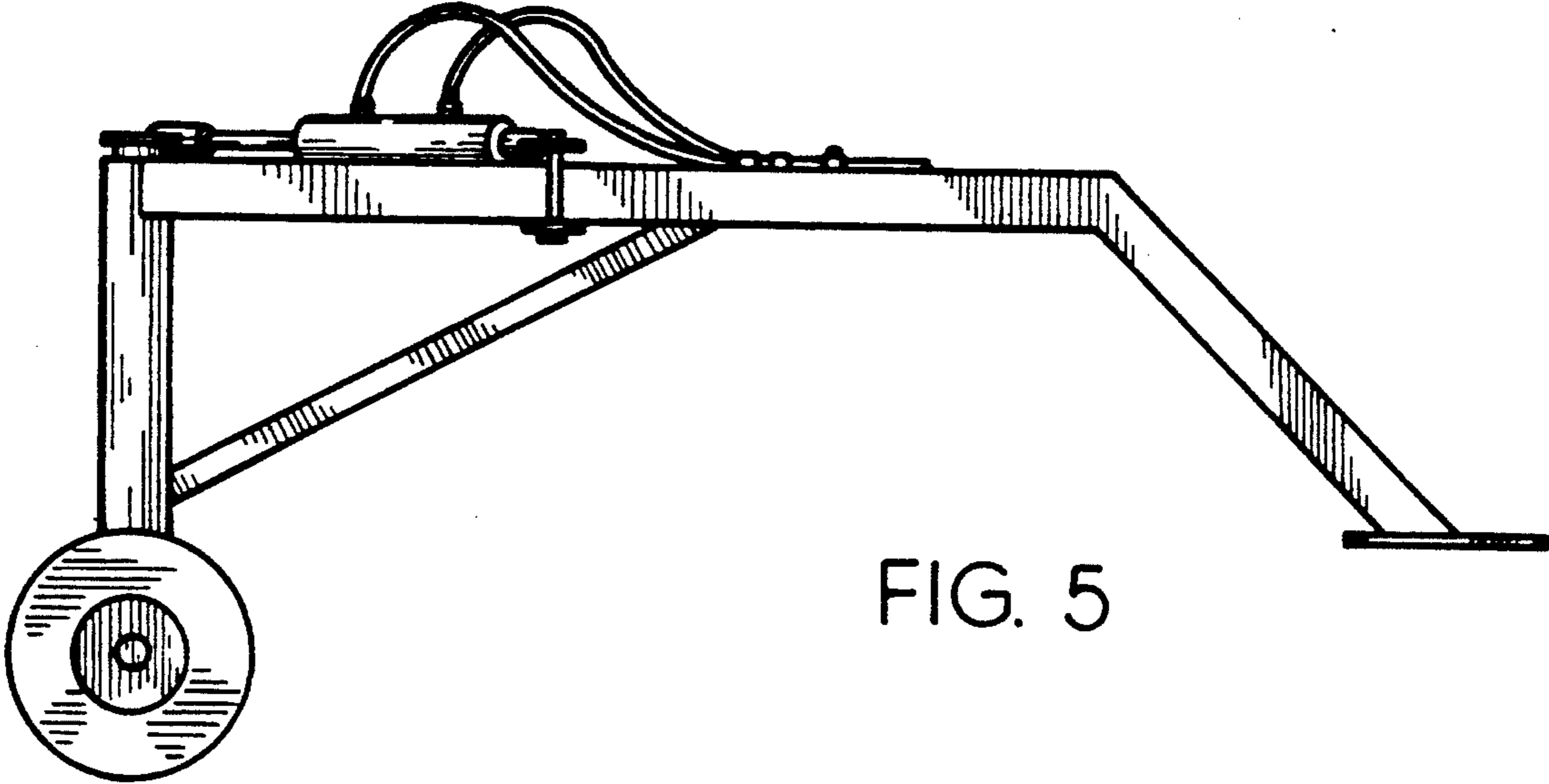

FIG. 5

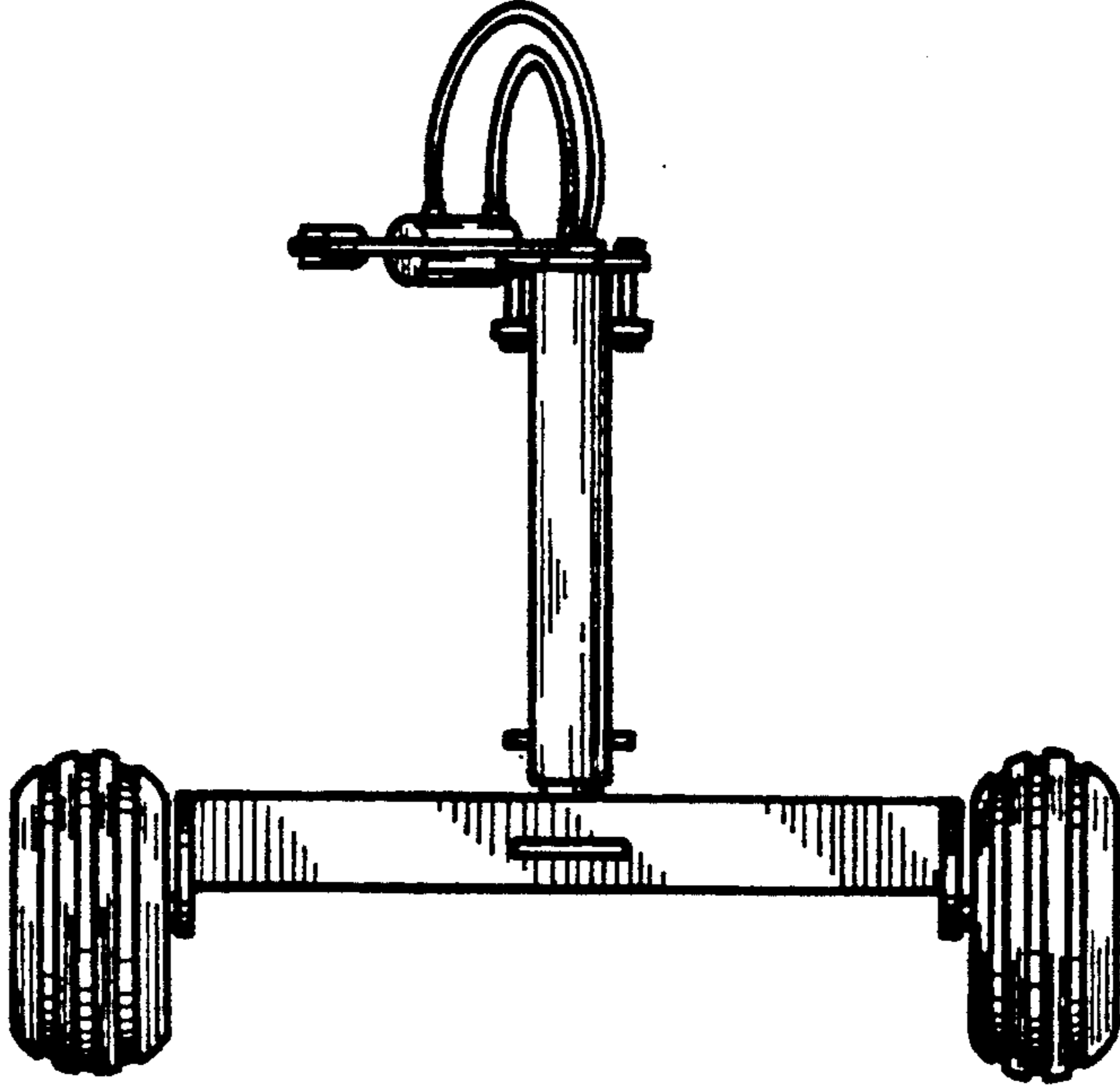

FIG. 3

