



US00D337095S

# United States Patent [19]

[11] Patent Number: **Des. 337,095**

Simonov et al.

[45] Date of Patent: **\*\* Jul. 6, 1993**

[54] **SPORTING AEROPLANE**

D. 239,522	4/1976	Wheatley	.....	D12/335
D. 244,843	6/1977	Paulson	.....	D12/337
D. 271,294	11/1983	Hank	.....	D12/344

[76] Inventors: **Mikhail P. Simonov**, Volokolamshoe shosse, 102-33, 123424, Moskva; **Boris V. Rakitin**, Severnoe Chertanovo, 6-607-379, 113648, Moskva; **Leonid G. Chernov**, Argunovskaya ul., 16-199, 129075, Moskva; **Stanislav T. Kashafutdinov**, 630099, Novosibirsk, all of U.S.S.R.

### OTHER PUBLICATIONS

Flight Int'l, Jun. 10, 1989, p. 49, "The Sukhoi SU-26M".

*Primary Examiner*—Kay H. Chin  
*Attorney, Agent, or Firm*—Ladas & Parry

[\*\*] Term: **14 Years**

### [57] CLAIM

[21] Appl. No.: **455,751**

The ornamental design for a sporting aeroplane, as shown and described.

[22] Filed: **Dec. 22, 1989**

### DESCRIPTION

[52] U.S. Cl. .... **D12/344; D12/337**

FIG. 1 is an enlarged left side, front and top perspective view of a sporting aeroplane showing our new design; FIG. 2 is a left side elevational view thereof; FIG. 3 is a right side elevation thereof; FIG. 4 is a front elevational view thereof; FIG. 5 is a top plan view thereof; FIG. 6 is a rear elevational view thereof; and, FIG. 7 is a bottom view thereof.

[58] Field of Search ..... **D12/319, 344, 335, 337, D12/338; 244/45 A, 29, 45 R**

### [56] References Cited

#### U.S. PATENT DOCUMENTS

D. 123,251 10/1940 Short et al. .... **D12/338**

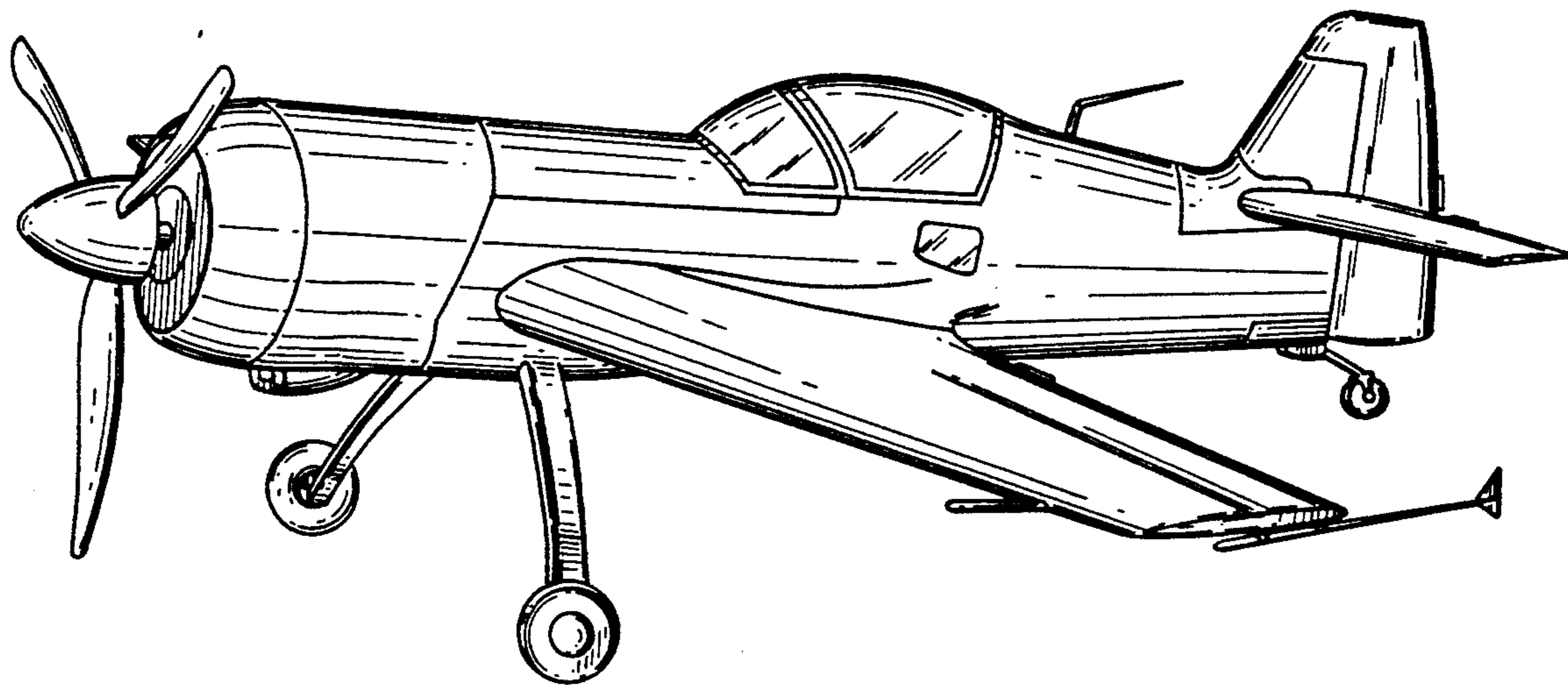

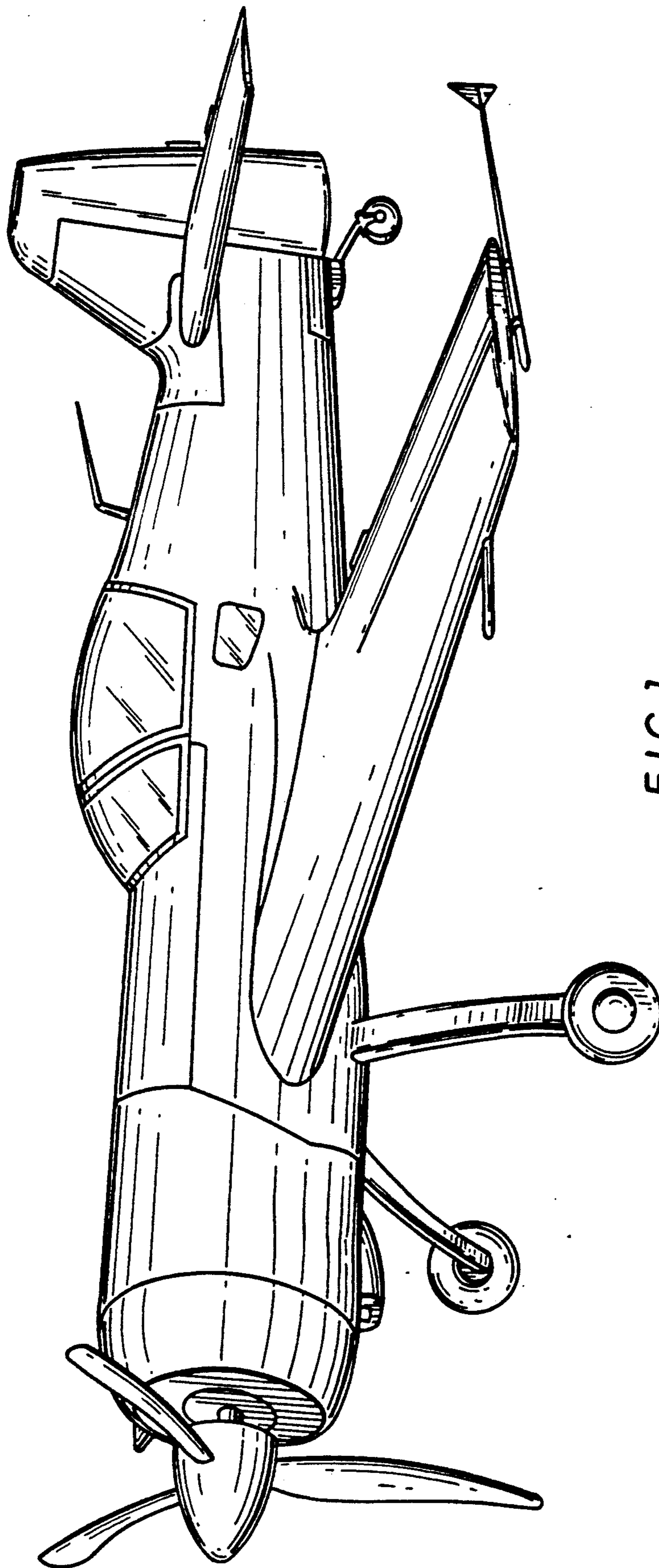

FIG. 1

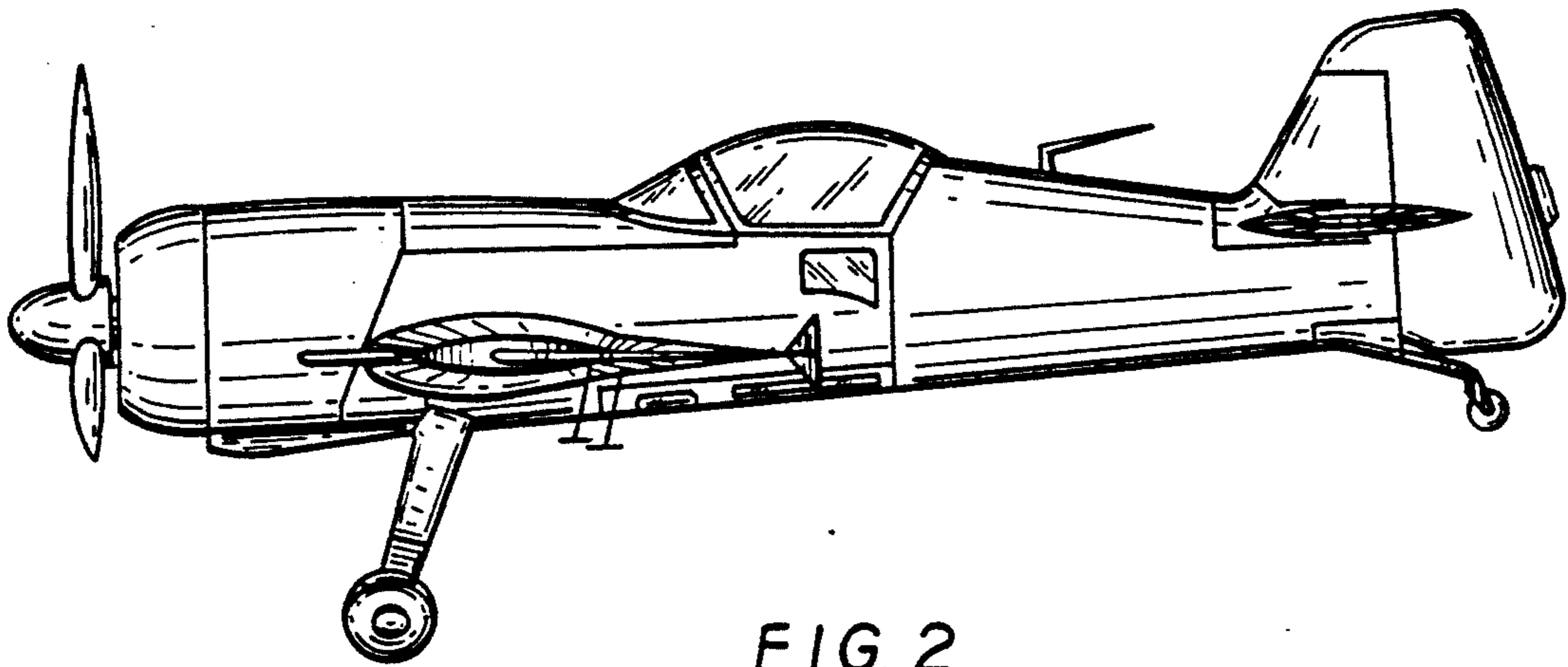

FIG. 2

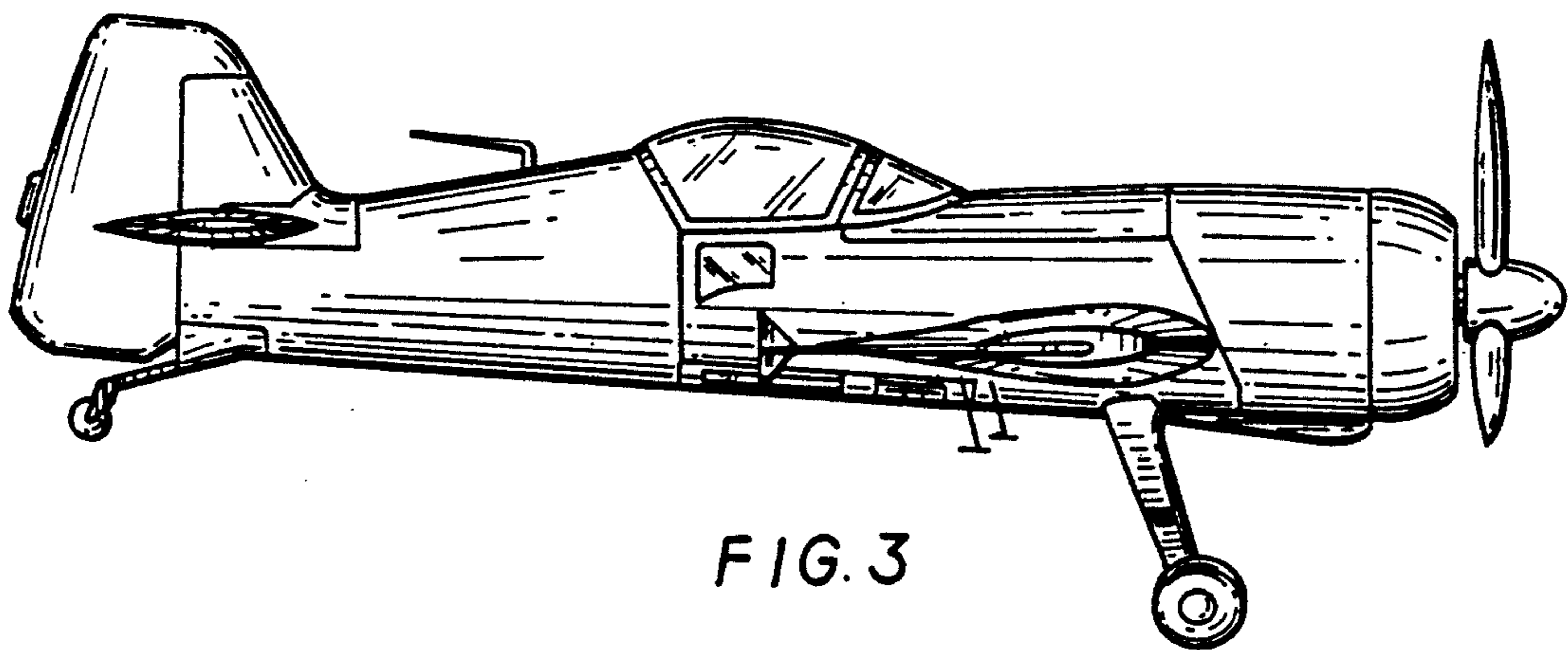

FIG. 3

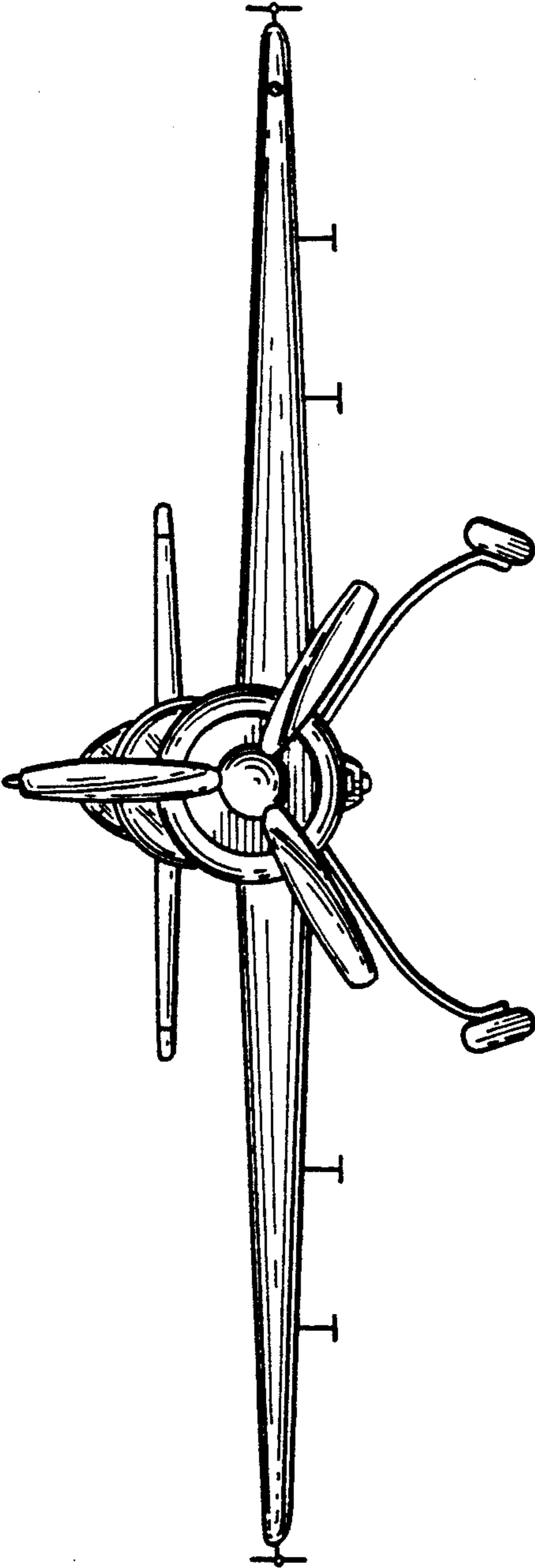

FIG. 4

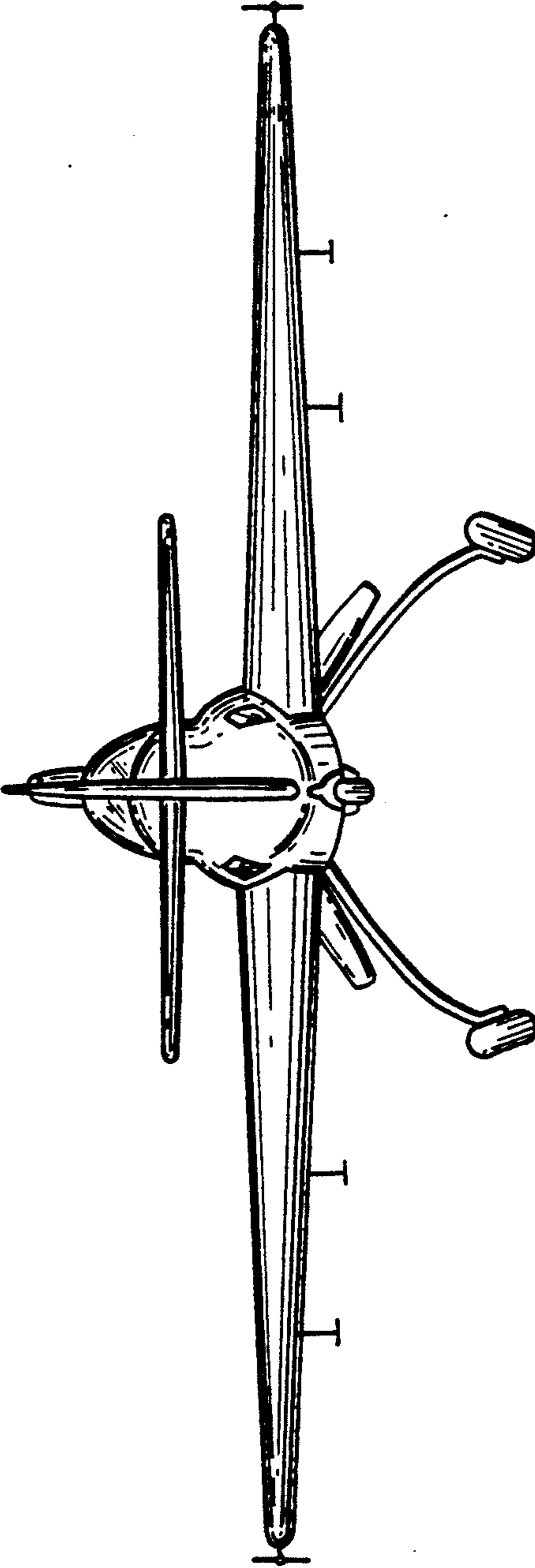

FIG. 6

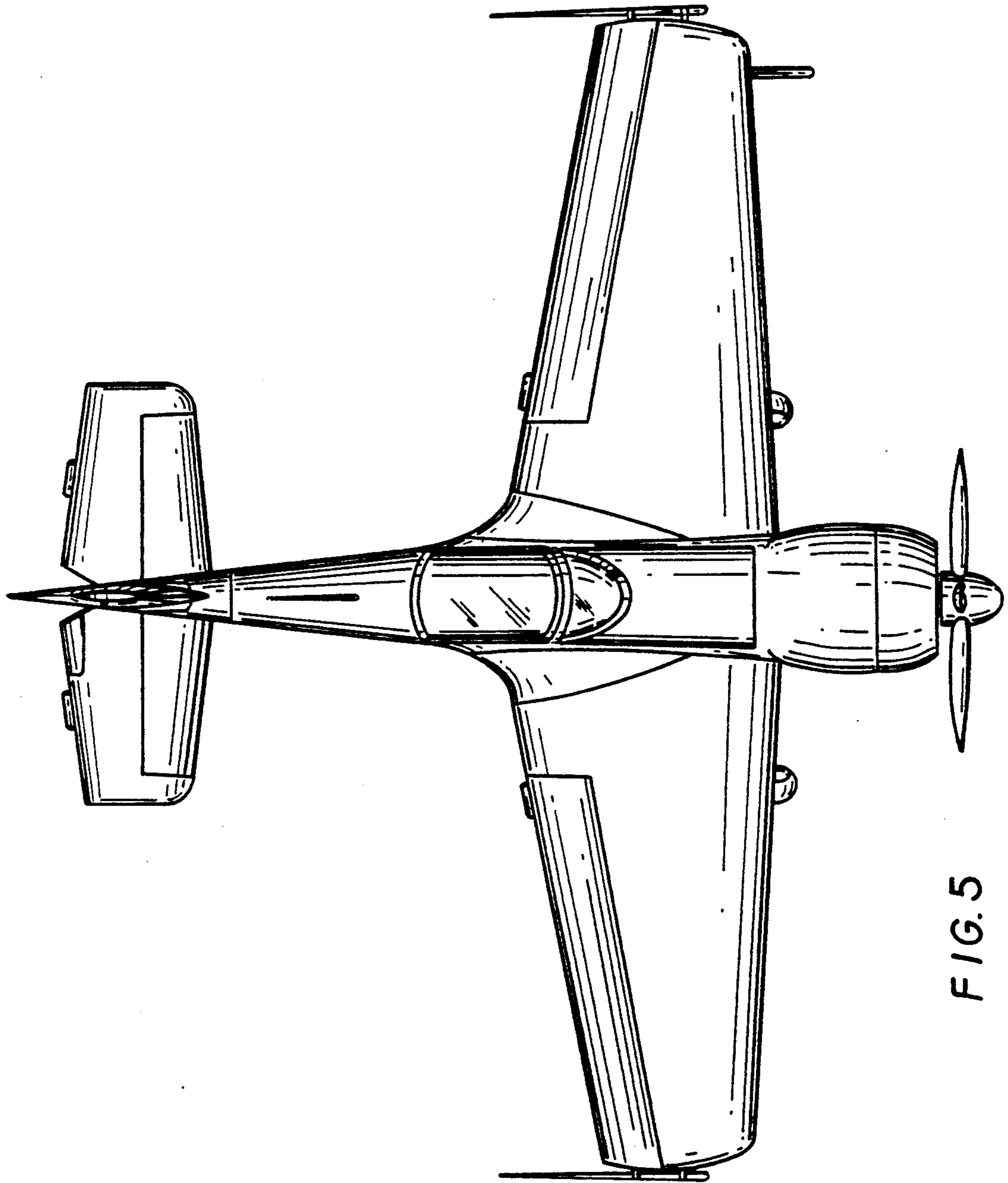

FIG. 5

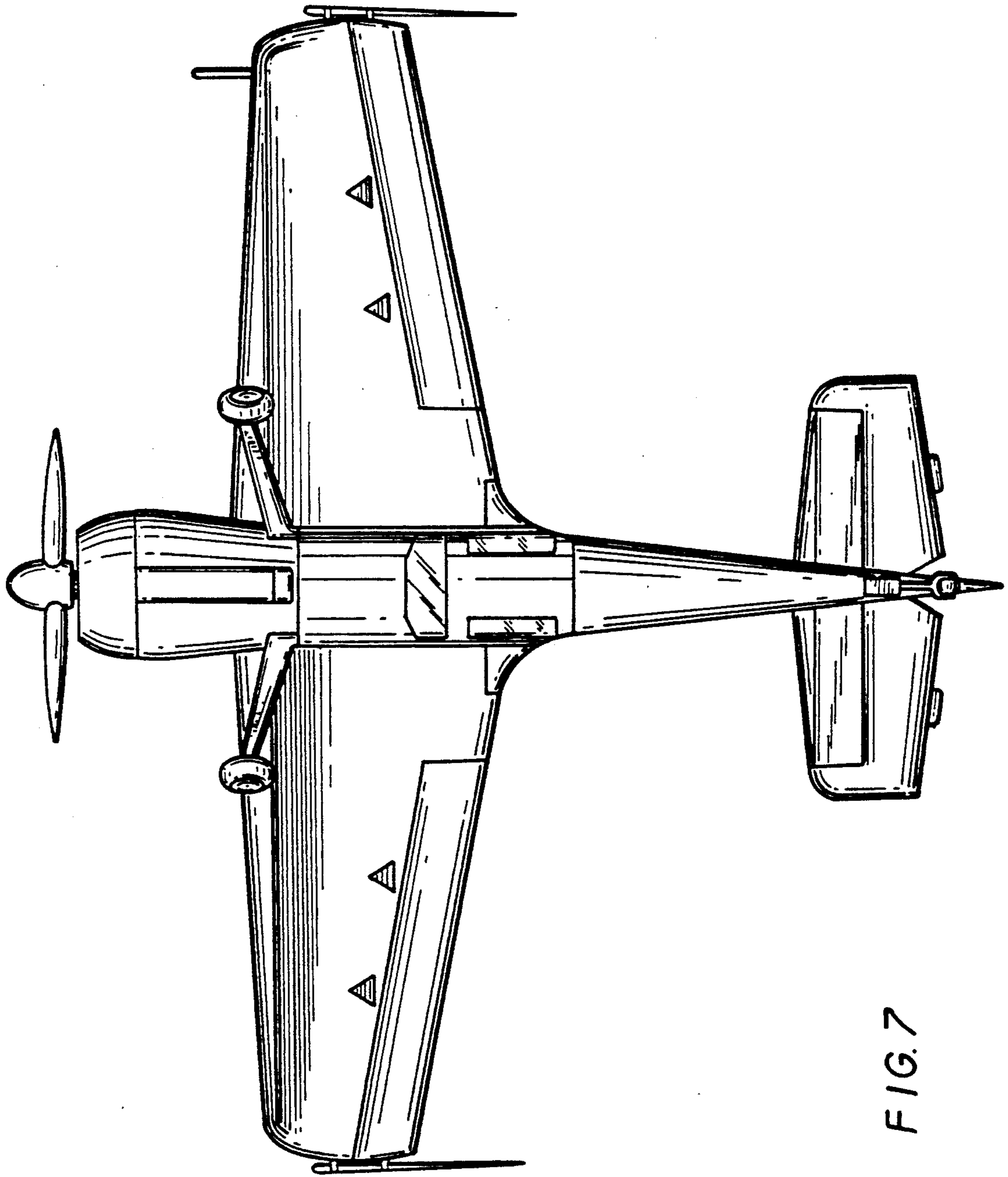

FIG. 7