



US00D337093S

United States Patent [19]

[11] Patent Number: **Des. 337,093**

Tane

[45] Date of Patent: **** Jul. 6, 1993**

[54] PILOTHOUSE

Primary Examiner—Kay H. Chin

[76] Inventor: **Seth Tane**, 1211 SW. 5th Ave.,
Portland, Oreg. 97204

[57] CLAIM

The ornamental design for a pilothouse, as shown and described.

[**] Term: **14 Years**

DESCRIPTION

[21] Appl. No.: **343,136**

FIG. 1 is a top, front and right side perspective view of a pilothouse showing my new design;

[22] Filed: **Apr. 24, 1989**

FIG. 2 is a reduced top perspective view thereof, the broken lines are for illustrative purposes only and form no part of the claimed design;

[52] U.S. Cl. **D12/318**

FIG. 3 is a right side elevational view thereof;

[58] Field of Search **D12/318, 315; D25/16;**

FIG. 4 is a front elevational view thereof;

114/343, 71

FIG. 5 is a left side elevational view thereof;

[56] References Cited

U.S. PATENT DOCUMENTS

D. 192,197 2/1962 Luger **D12/318**

D. 232,425 8/1974 Marriner **D12/315**

D. 304,571 11/1989 Lindstrom et al. **D12/318**

OTHER PUBLICATIONS

Trailer Boats, Nov./Dec. 1982, p. 23, Clippercraft Dories.

FIG. 6 is a rear elevational view thereof;

FIG. 7 is a cross sectional view taken along the line 7—7 of FIG. 6;

FIG. 8 is a top plan view thereof;

FIG. 9 is a right side elevational view of a second embodiment of the pilothouse; and,

FIG. 10 is a top, front and left side perspective view of FIG. 9.

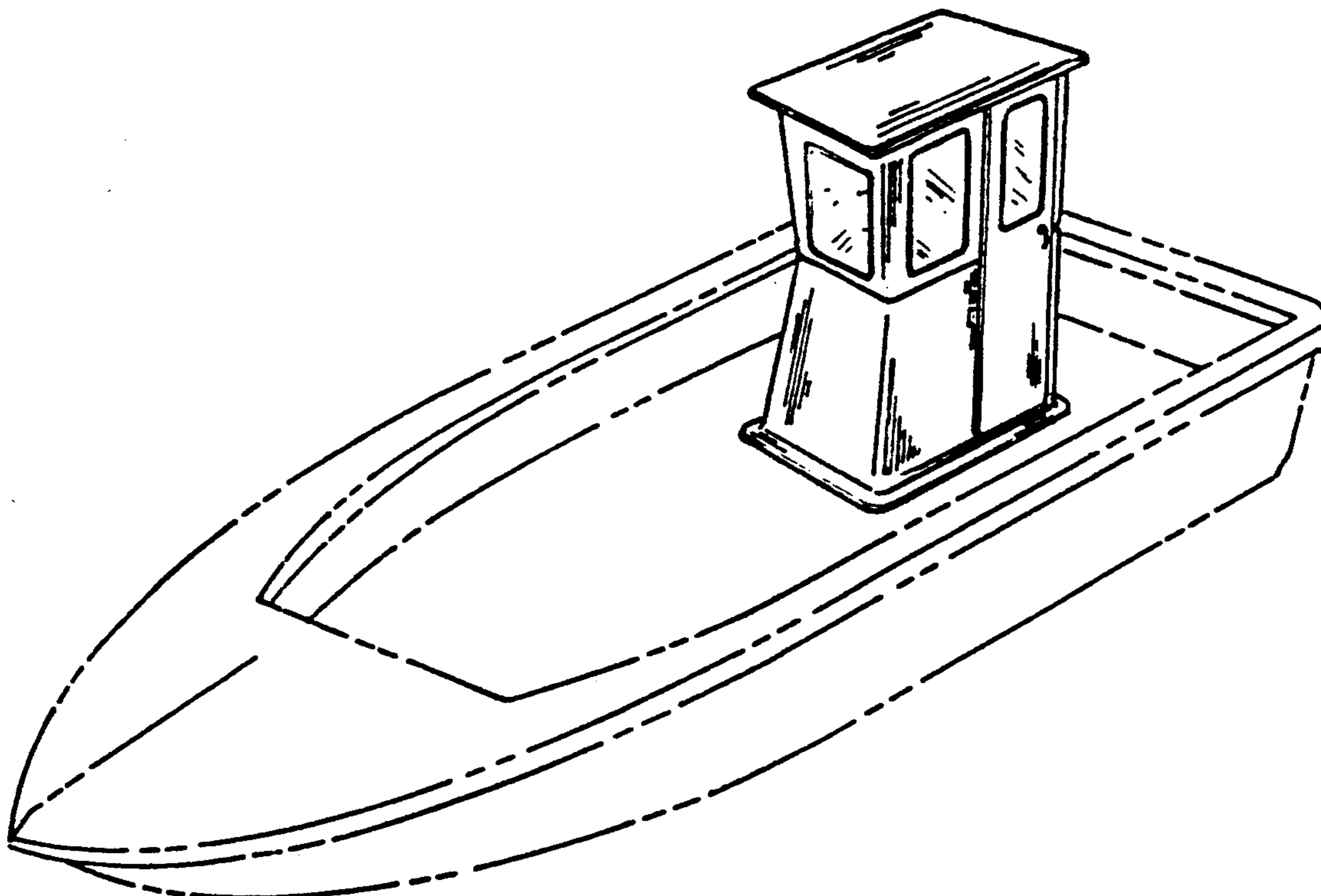

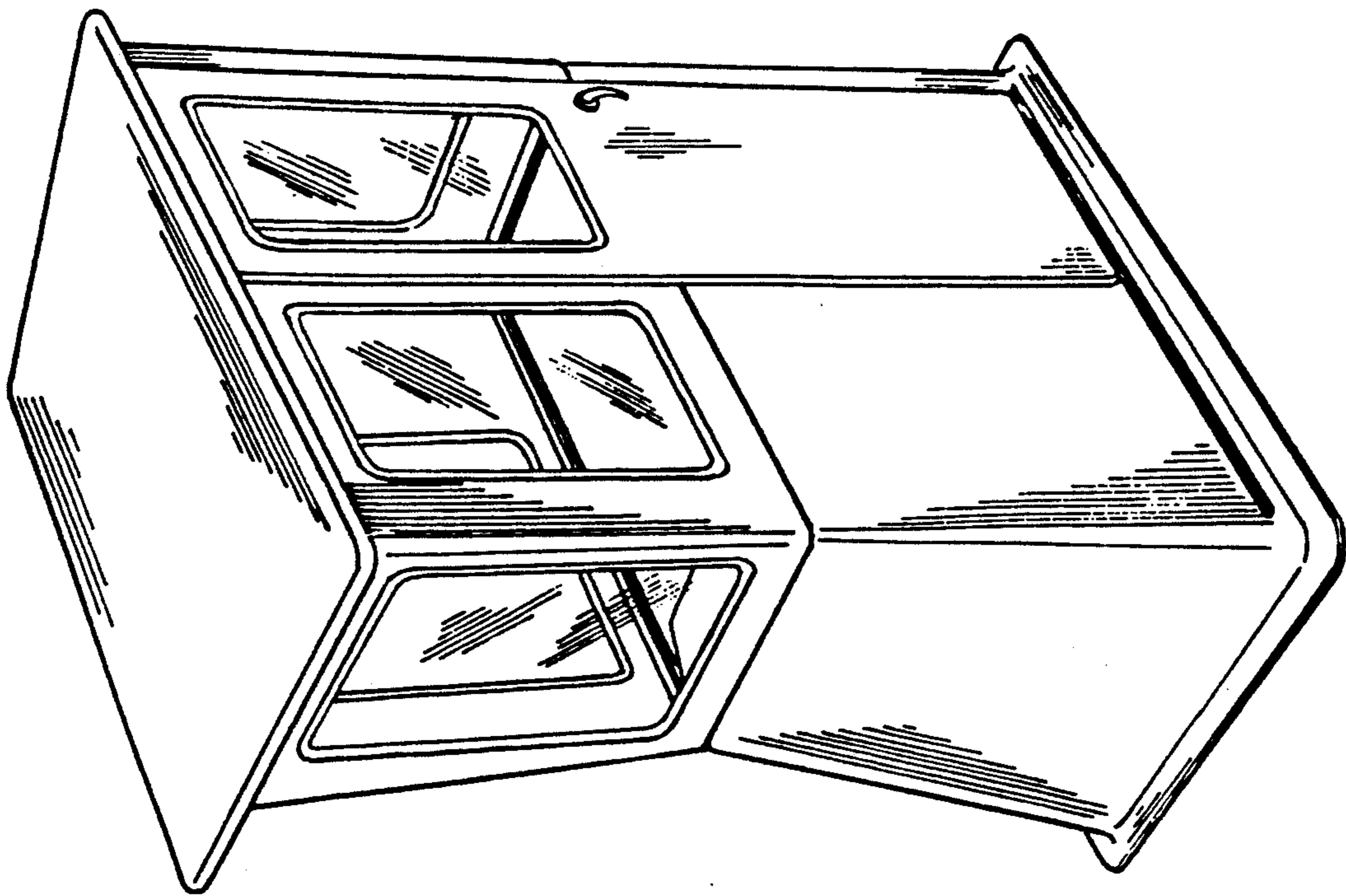

fig. 1

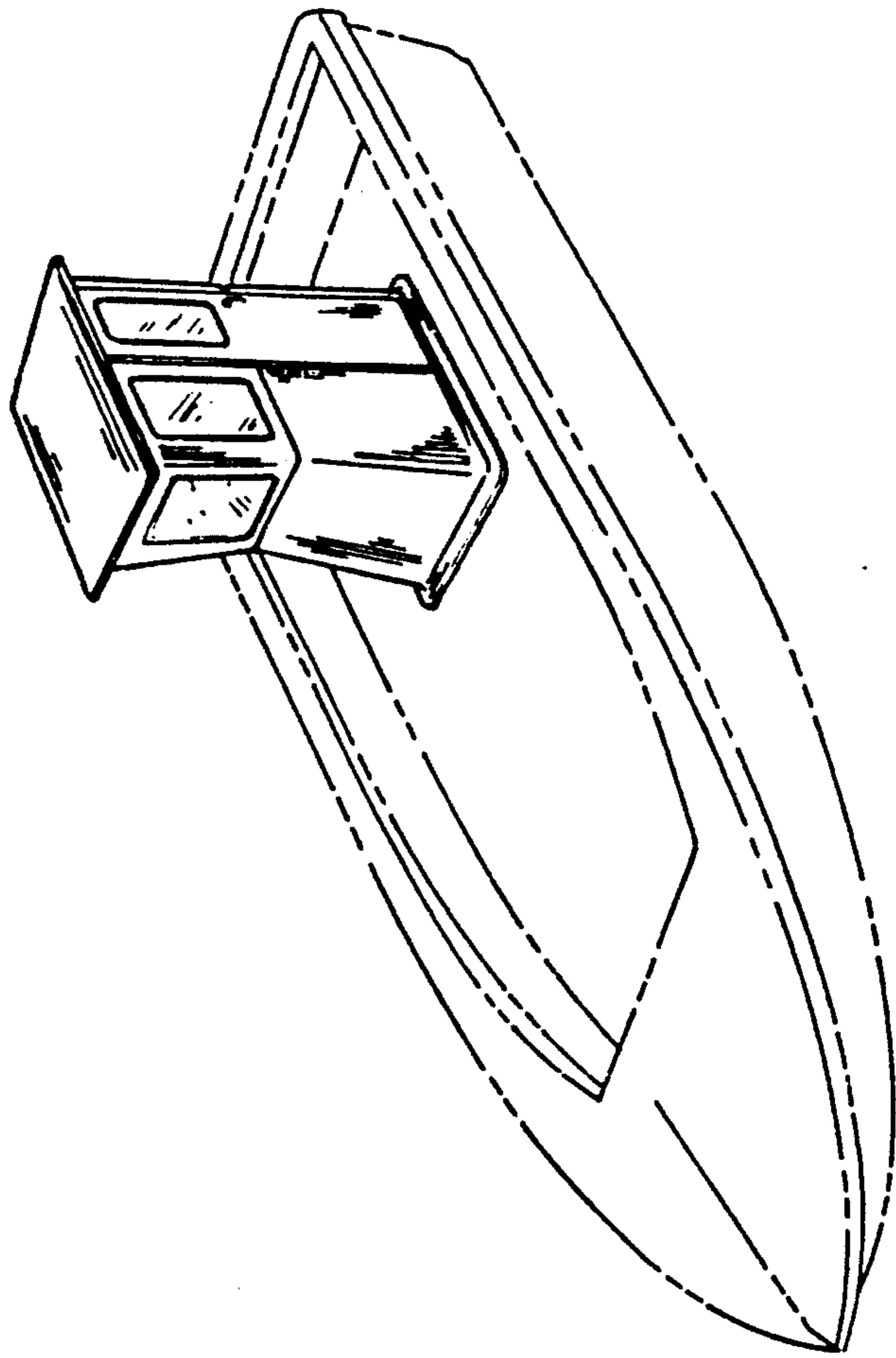

fig. 2

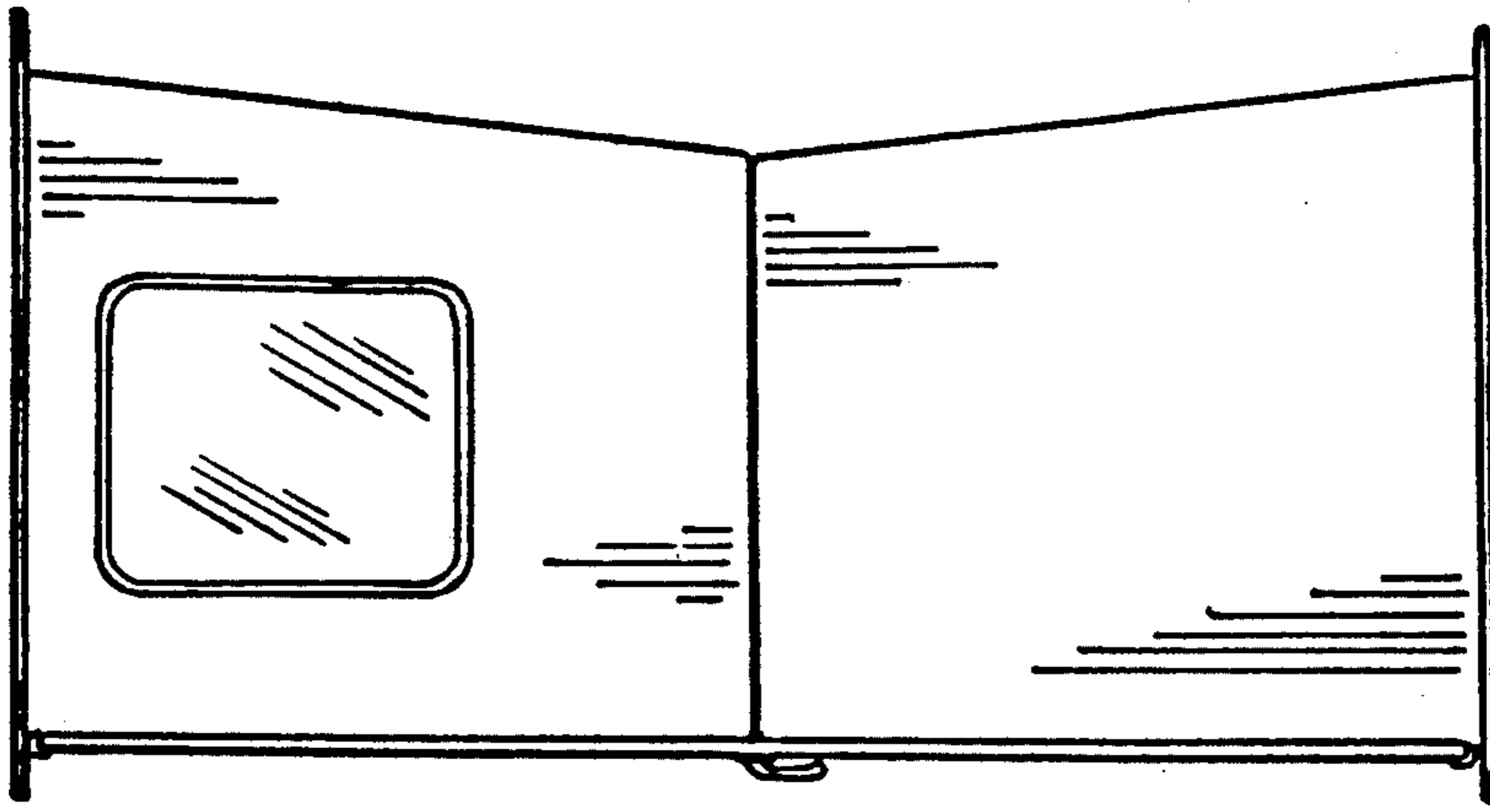

fig. 5

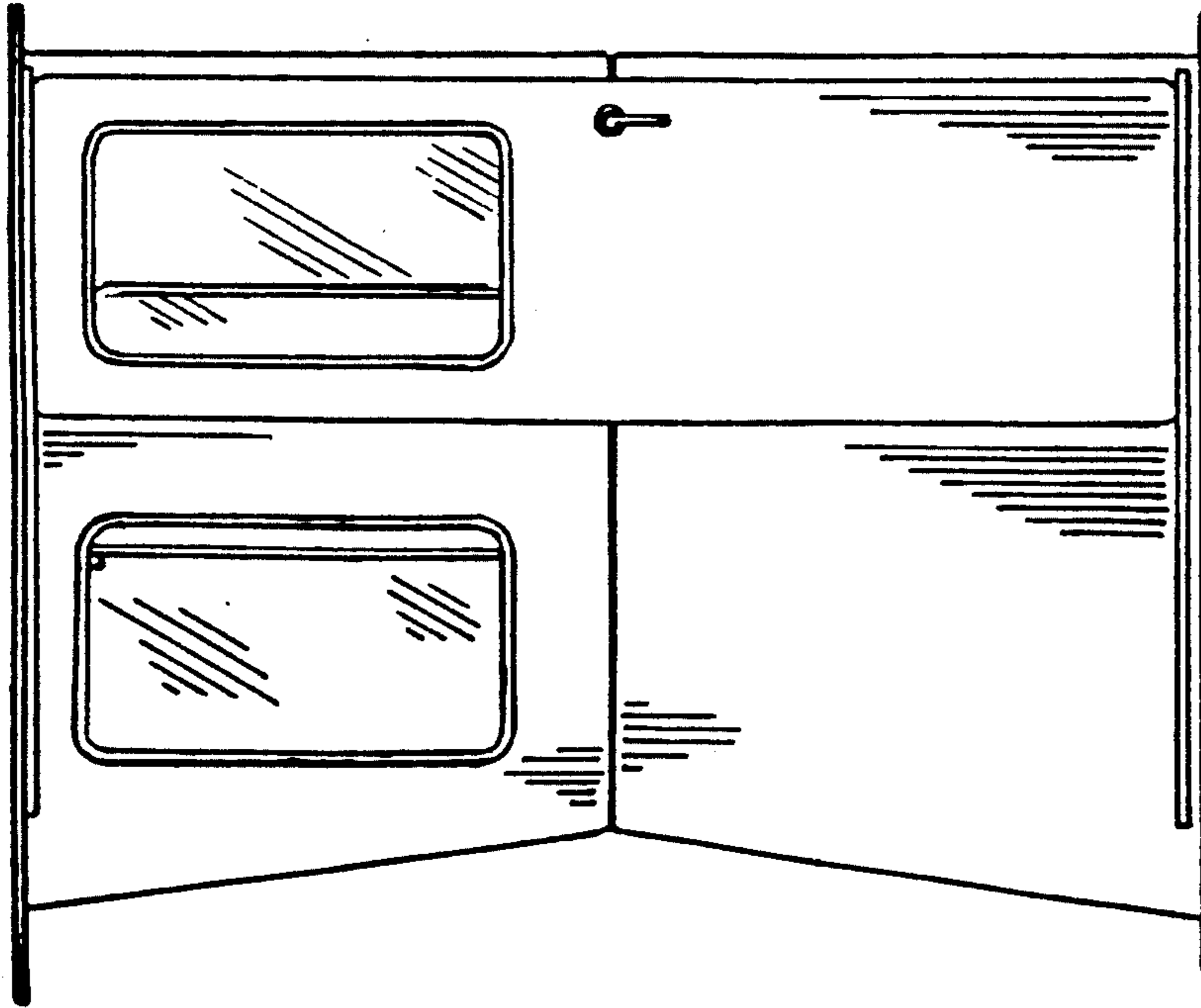

fig. 4

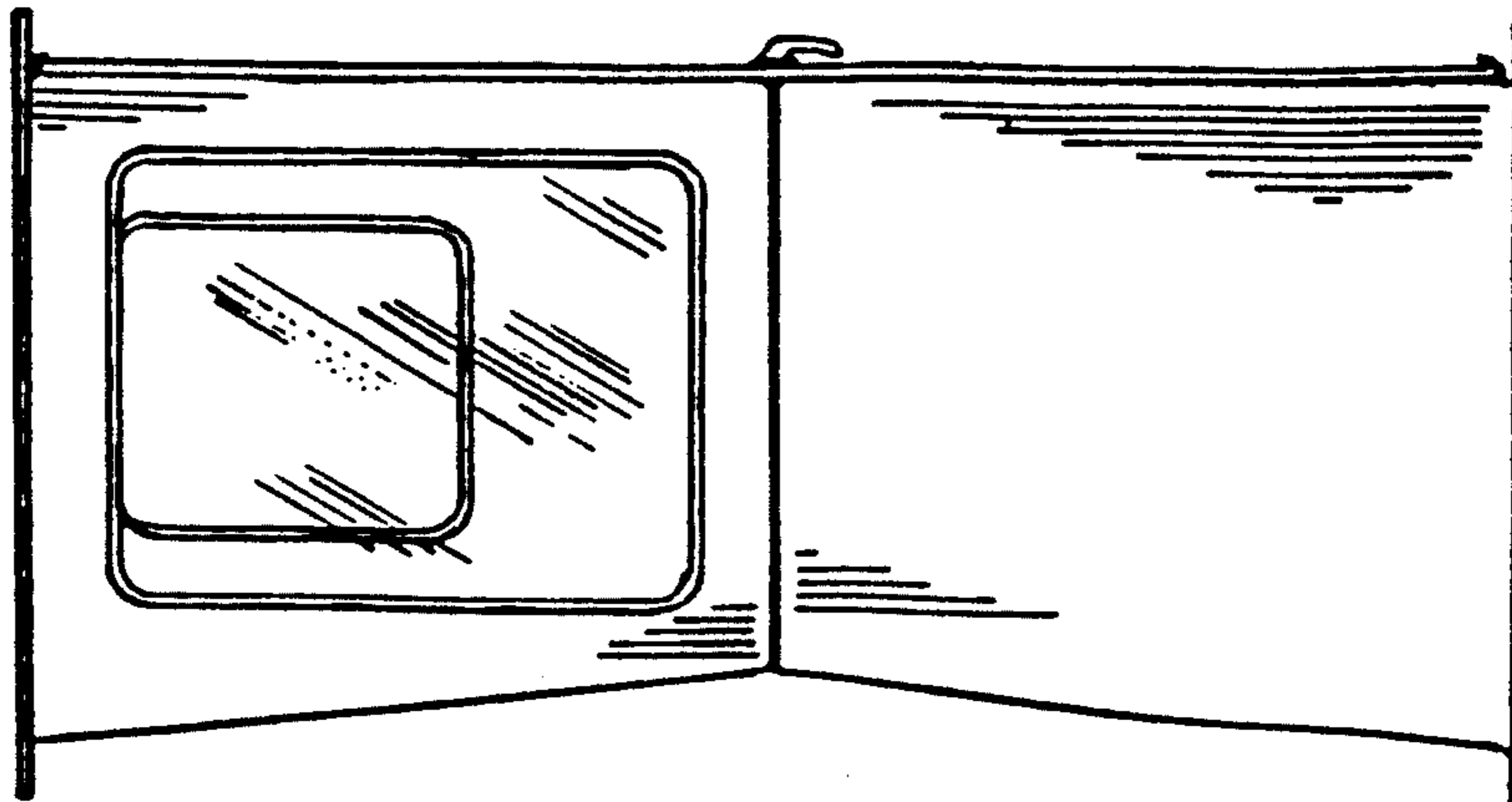

fig. 3

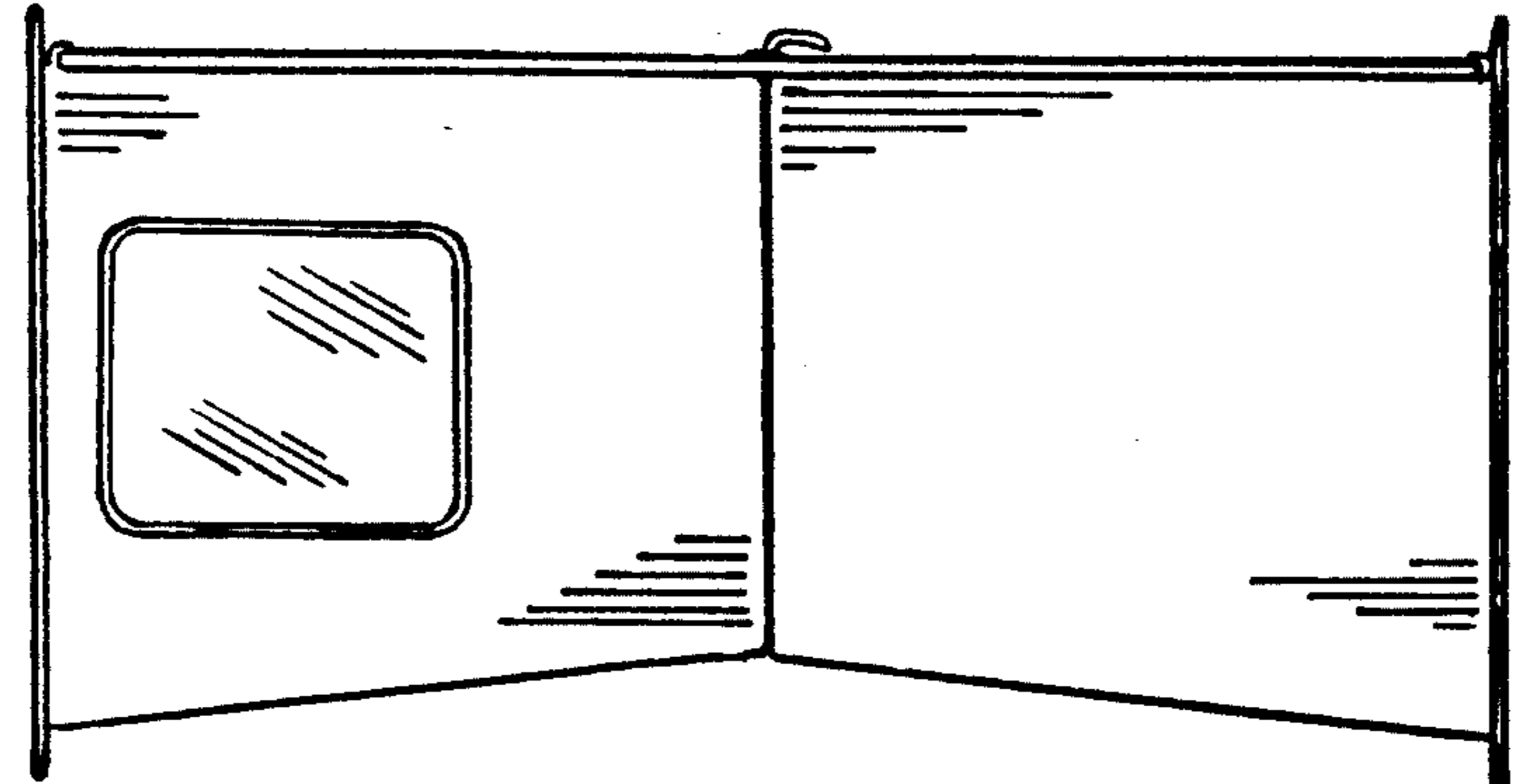

fig. 9

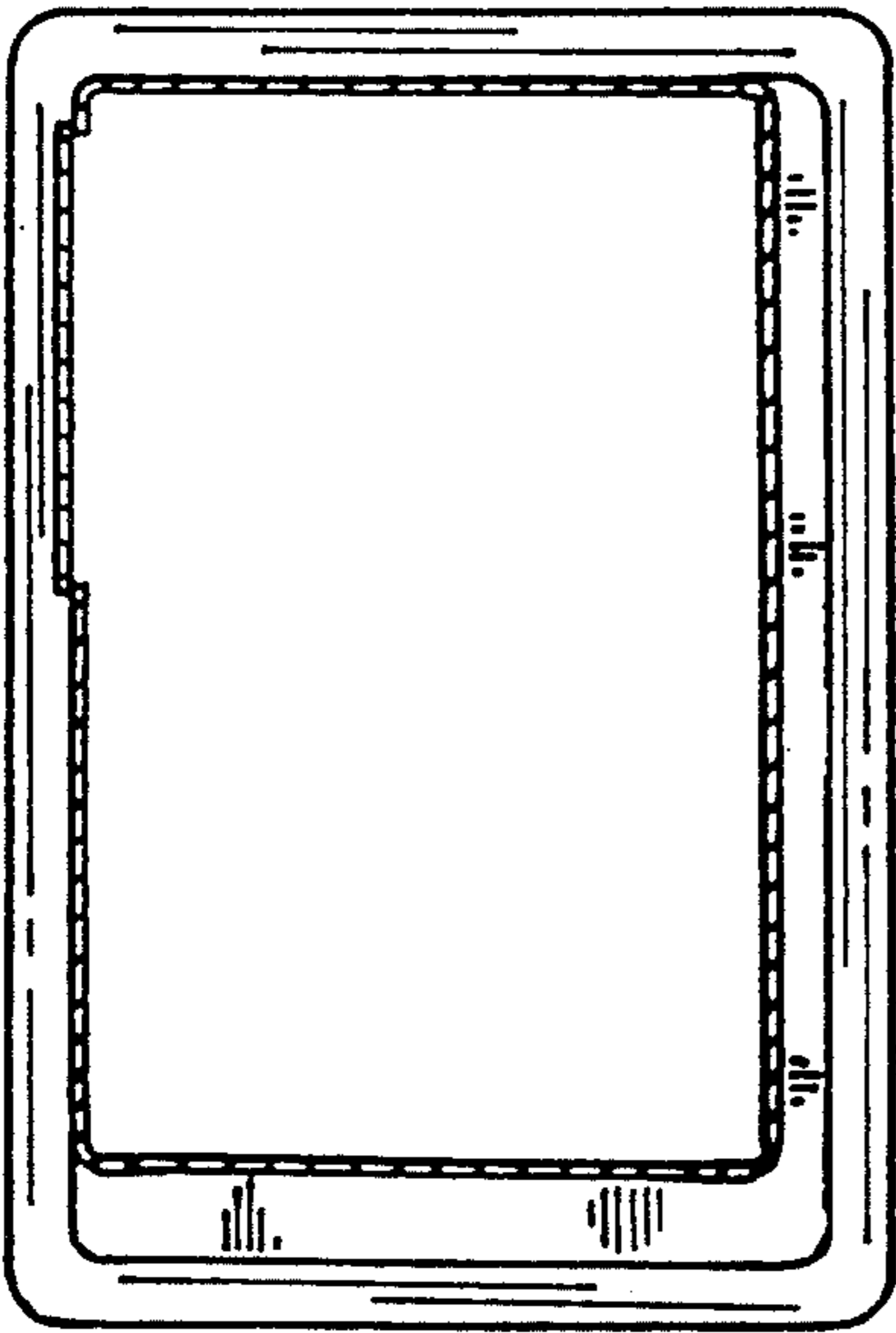

fig. 7

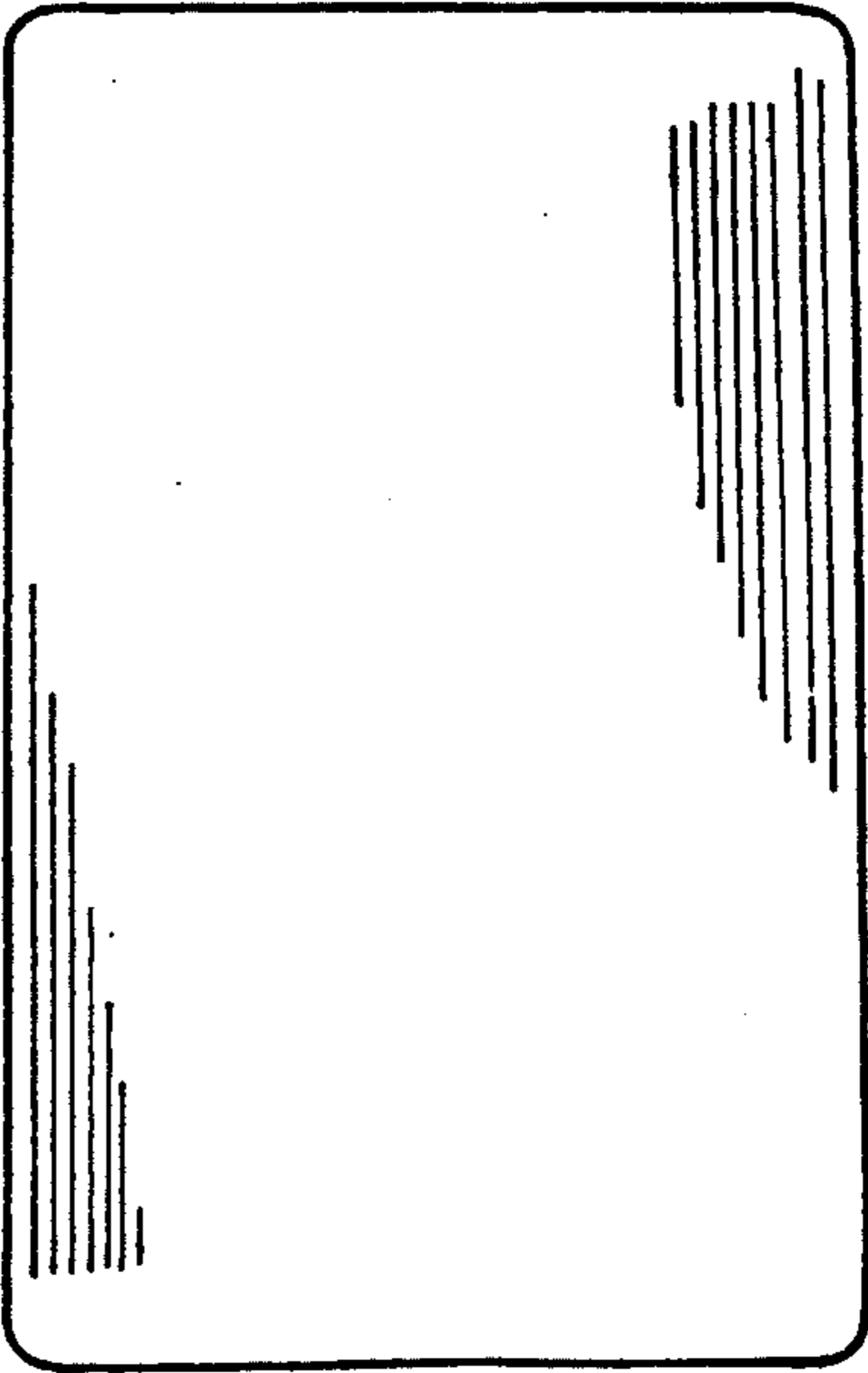

fig. 8

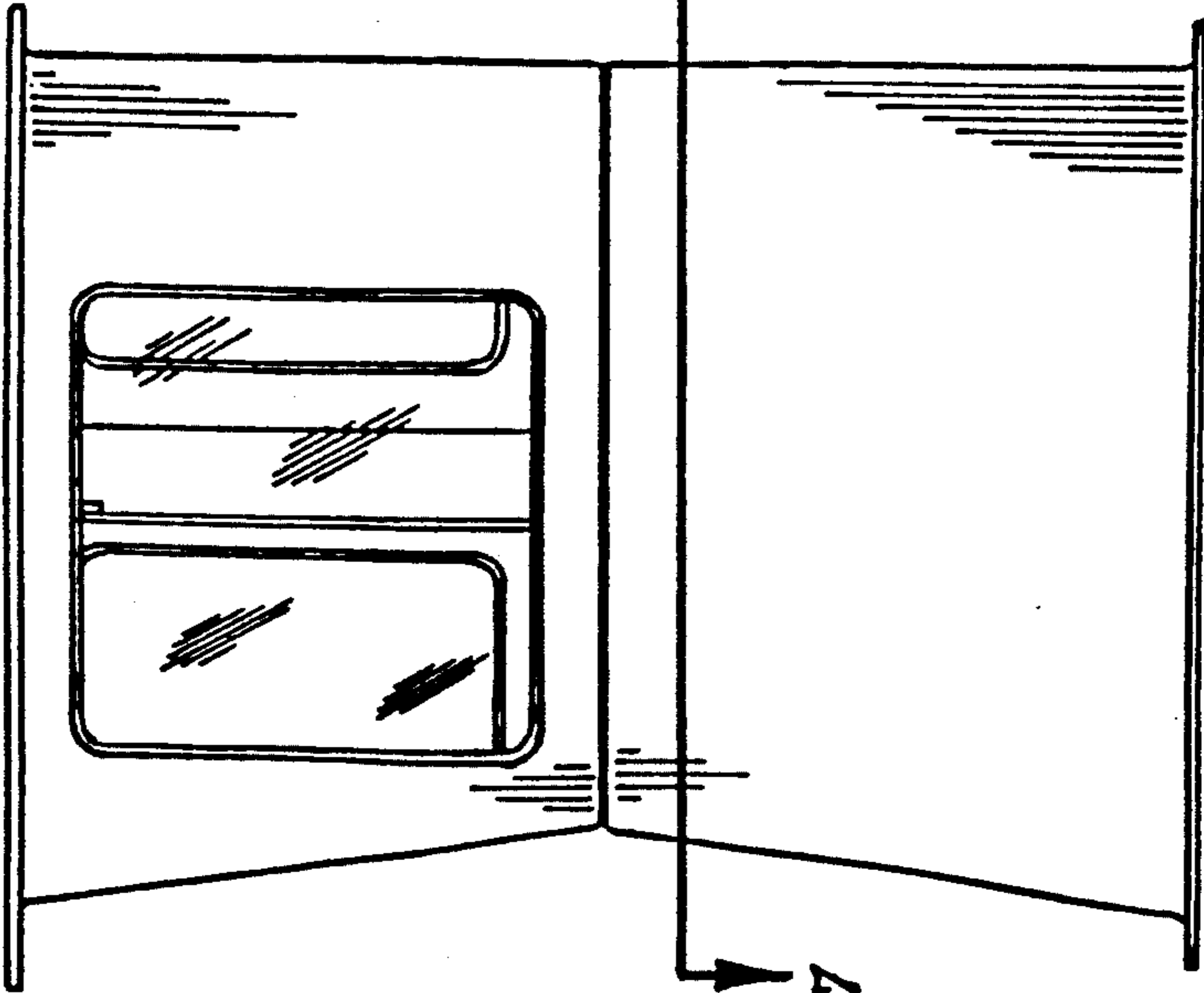

fig. 6

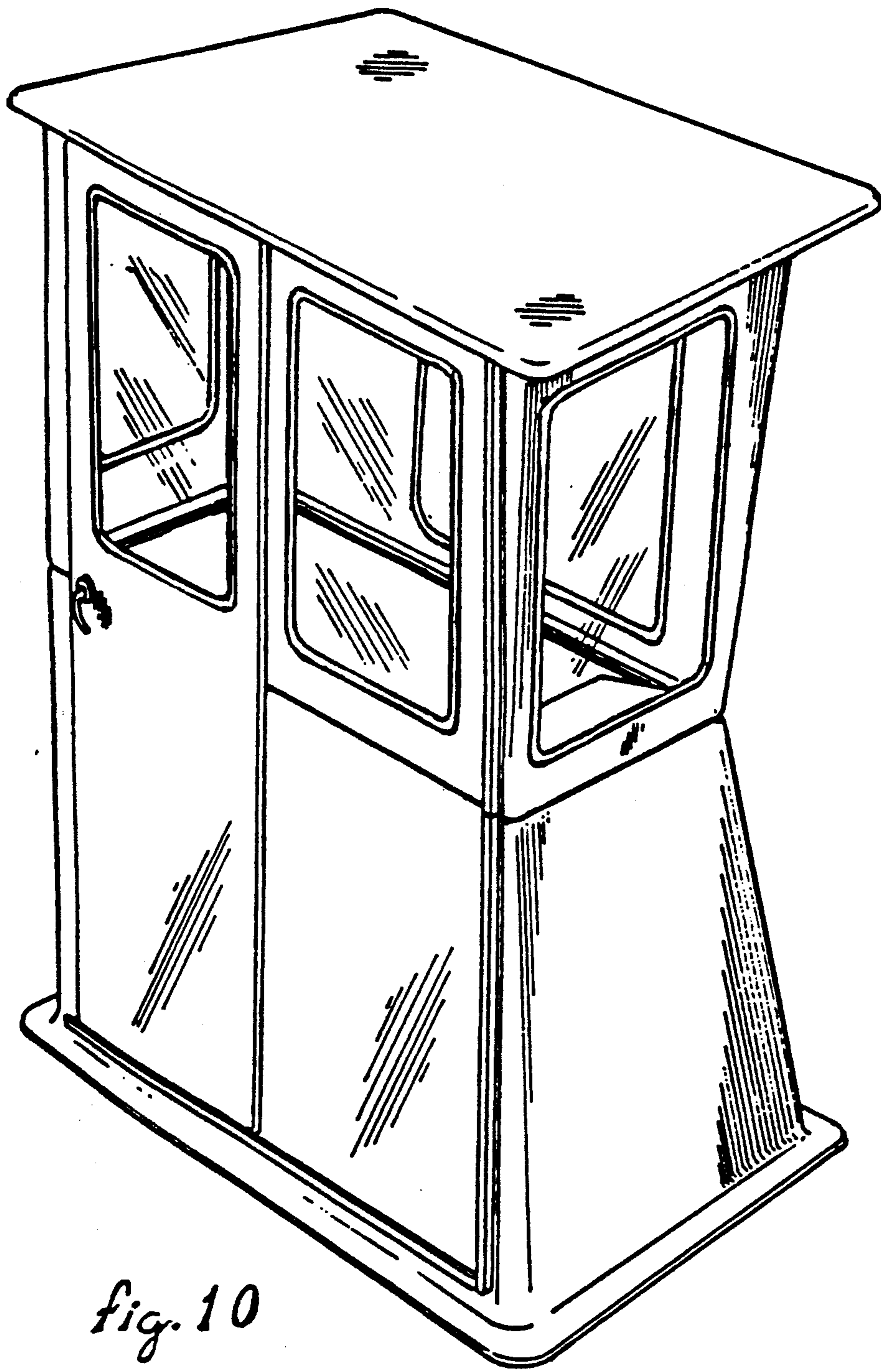

fig. 10