



US00D337066S

United States Patent [19]

[11] Patent Number: **Des. 337,066**

Thompson

[45] Date of Patent: **** Jul. 6, 1993**

[54] **COMBINED TRANSMITTER AND RECEIVER FOR TRAFFIC CONTROL OF EMERGENCY VEHICLES**

4,914,434 4/1990 Morgan et al. 340/906
5,014,052 5/1991 Obeck 340/906

[76] Inventor: **V. P. Thompson**, 108 N. Armstrong, Bixby, Okla. 74008

Primary Examiner—Wallace R. Burke
Assistant Examiner—Marcus Jackson
Attorney, Agent, or Firm—Terry M. Gernstein

[**] Term: **14 Years**

[57] **CLAIM**

[21] Appl. No.: **486,194**

The ornamental design for combined transmitter and receiver for traffic control of emergency vehicles, as shown and described.

[22] Filed: **Feb. 28, 1990**

DESCRIPTION

[52] U.S. Cl. **D10/104; D10/109**

[58] Field of Search **D10/104, 109, 112, 114, D10/115, 121; 340/906, 907, 908, 908.1, 909, 910, 911, 915; 362/240, 227, 236, 243**

FIG. 1 is a perspective view of a embodying the design of the present invention;
FIG. 2 is a front elevational view of the transmitter portion;
FIG. 3 is an end elevational view thereof;
FIG. 4 is a rear elevational view thereof;
FIG. 5 is an end elevational view thereof;
FIG. 6 is a top plan view thereof;
FIG. 7 is a bottom view thereof;
FIG. 8 is a front elevational view of the receiver portion;
FIG. 9 is an end elevational view thereof;
FIG. 10 is a rear elevational view thereof;
FIG. 11 is an end elevational view thereof;
FIG. 12 is a top plan view thereof; and,
FIG. 13 is a bottom view thereof.

[56] **References Cited**

U.S. PATENT DOCUMENTS

D. 315,696	3/1991	Kearns	D10/115
2,001,440	5/1935	West	D10/115
3,257,641	6/1966	Campana et al.	340/906
3,550,078	12/1970	Long	340/906
3,881,169	4/1975	Malach	340/906
4,017,825	4/1977	Pickey	340/906
4,573,049	2/1986	Obeck	.	
4,704,610	11/1987	Smith	.	
4,736,186	4/1988	Jones	340/906
4,775,865	9/1988	Smith	.	

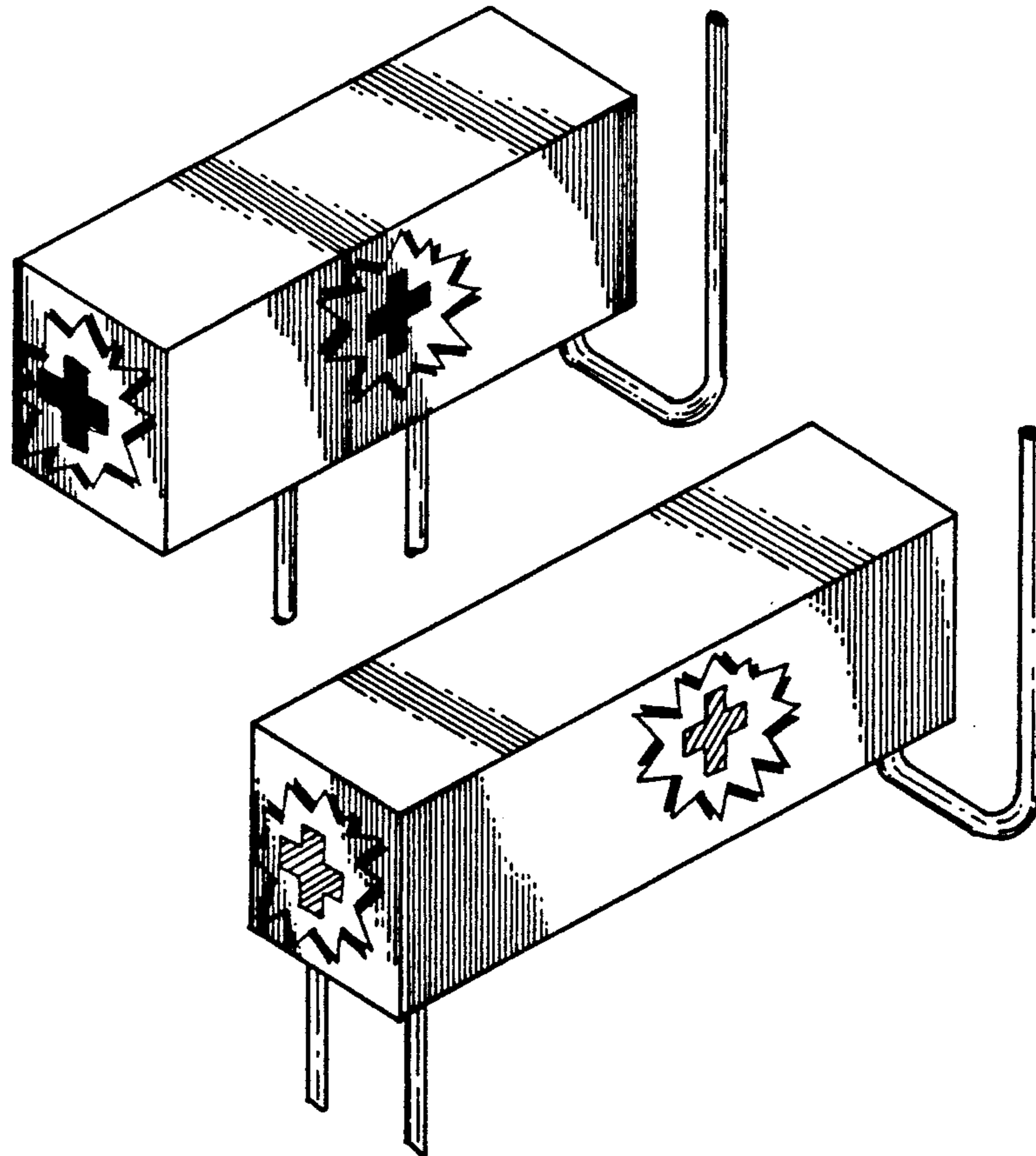

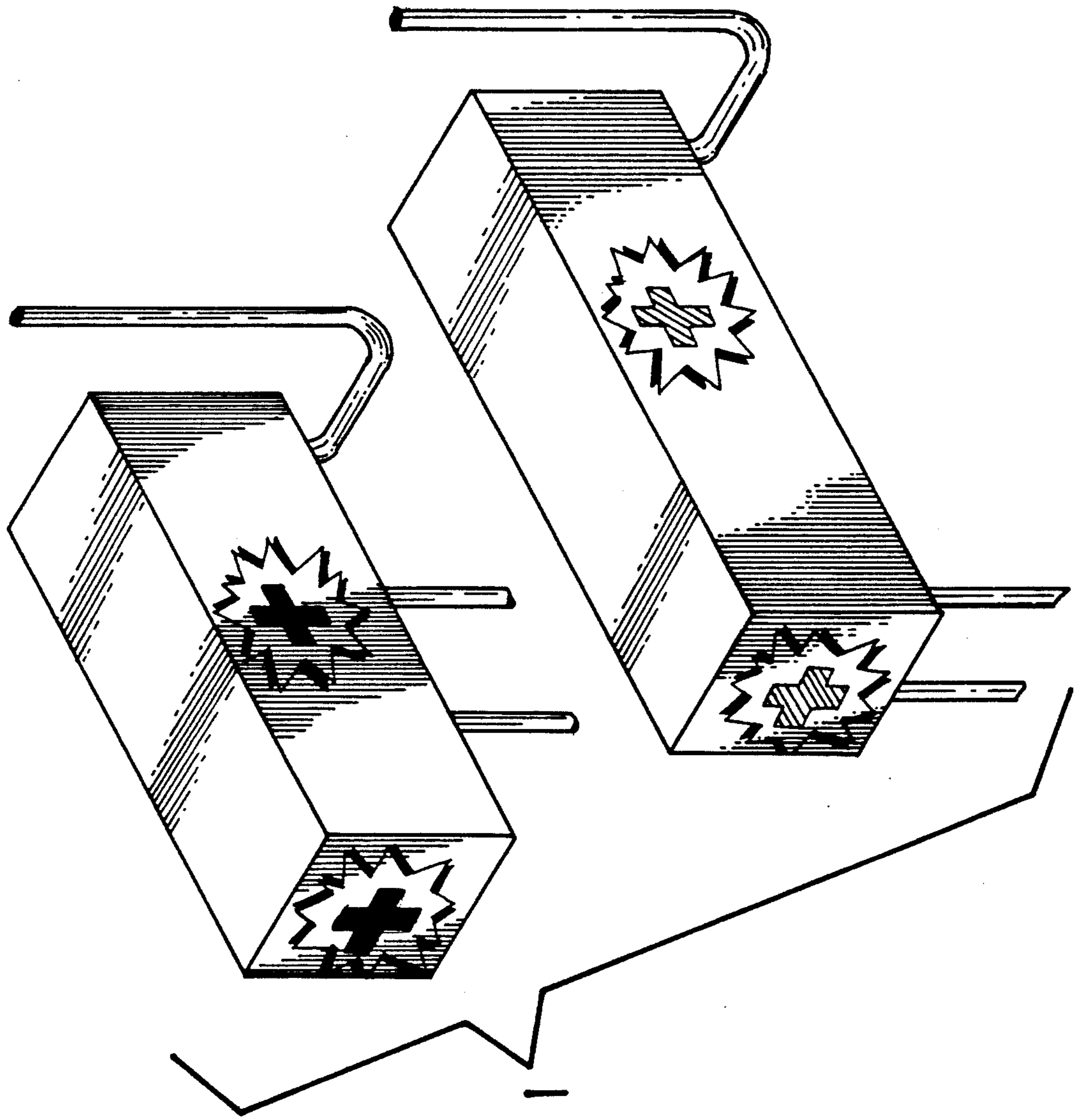

FIG. 1

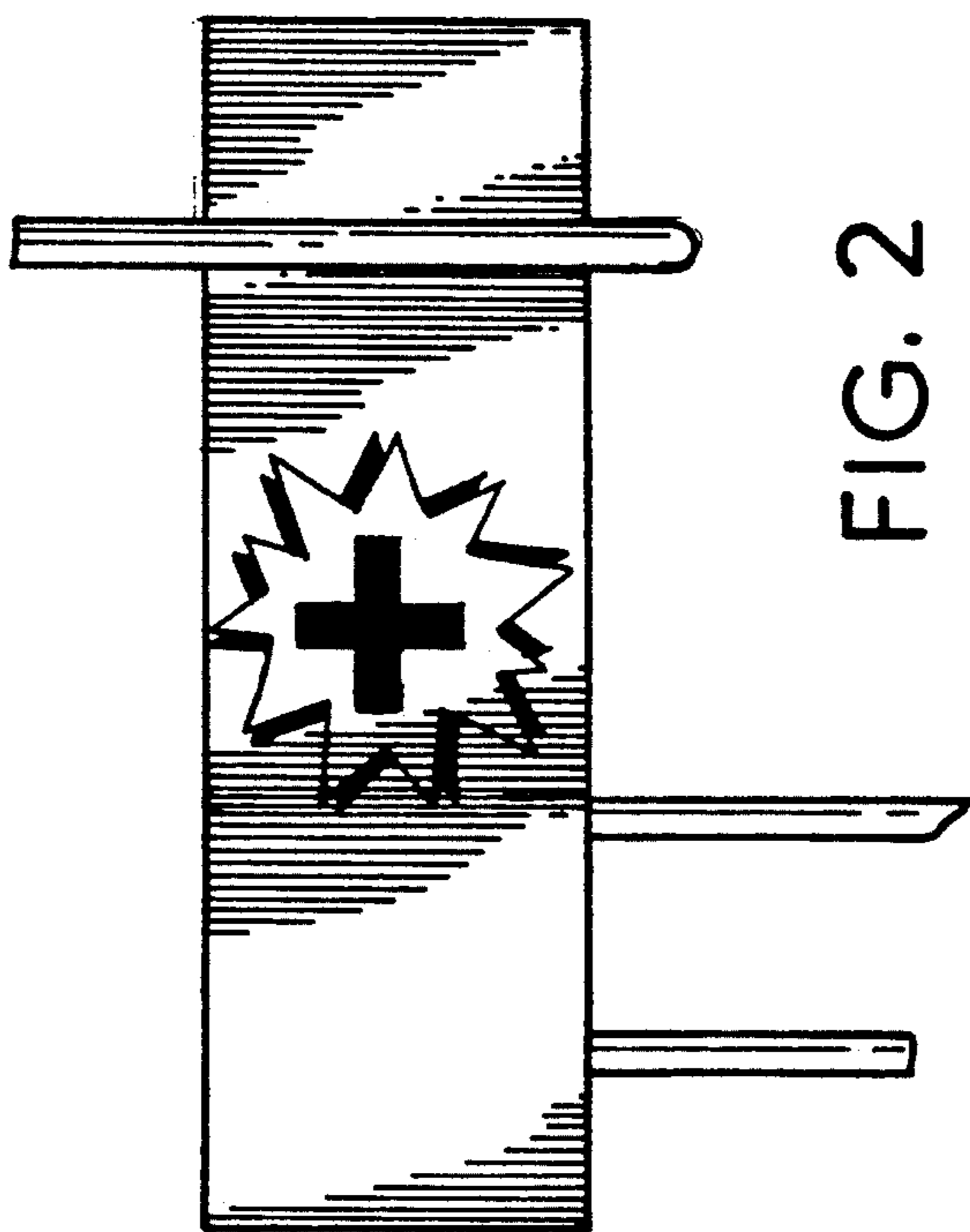

FIG. 2

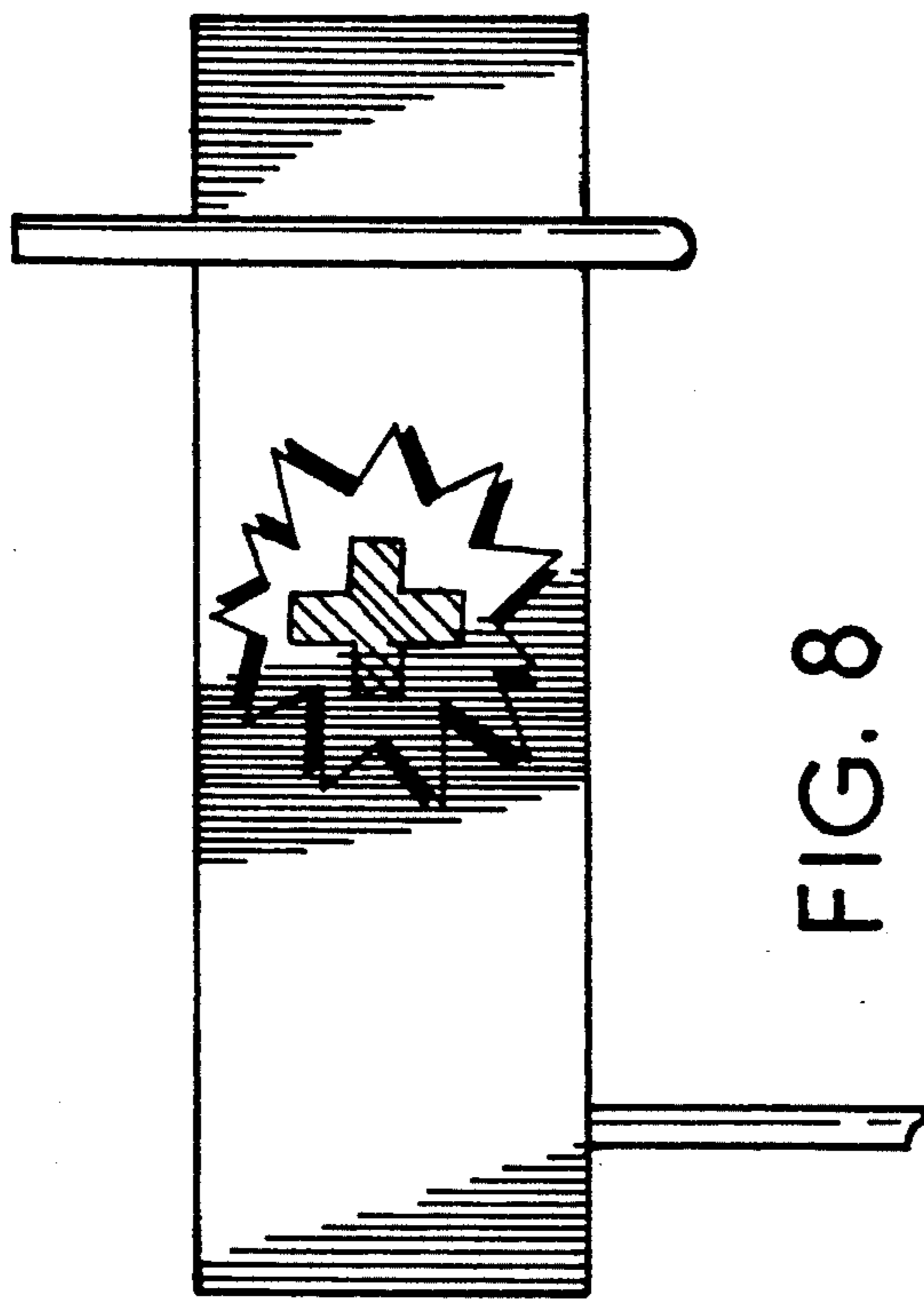

FIG. 8

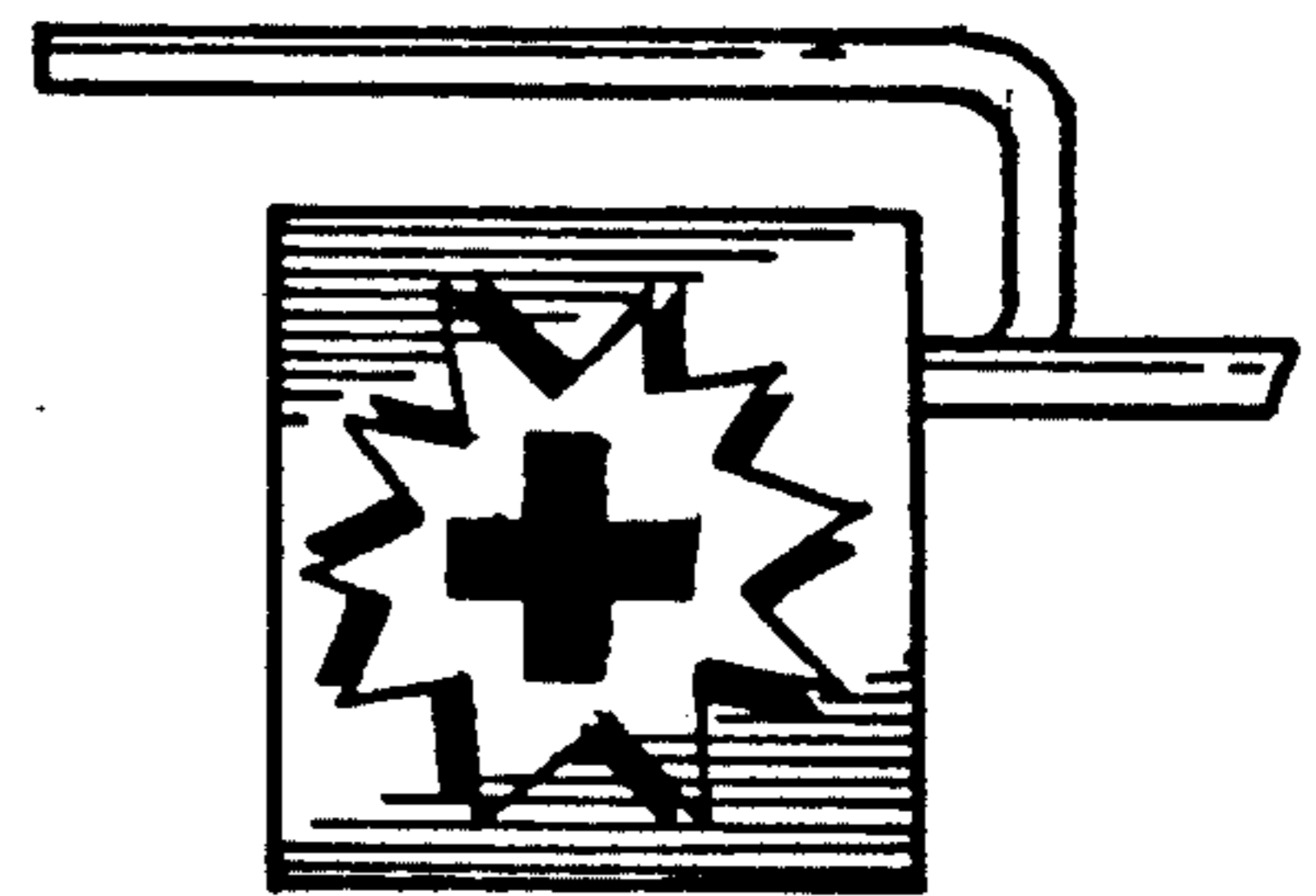

FIG. 3

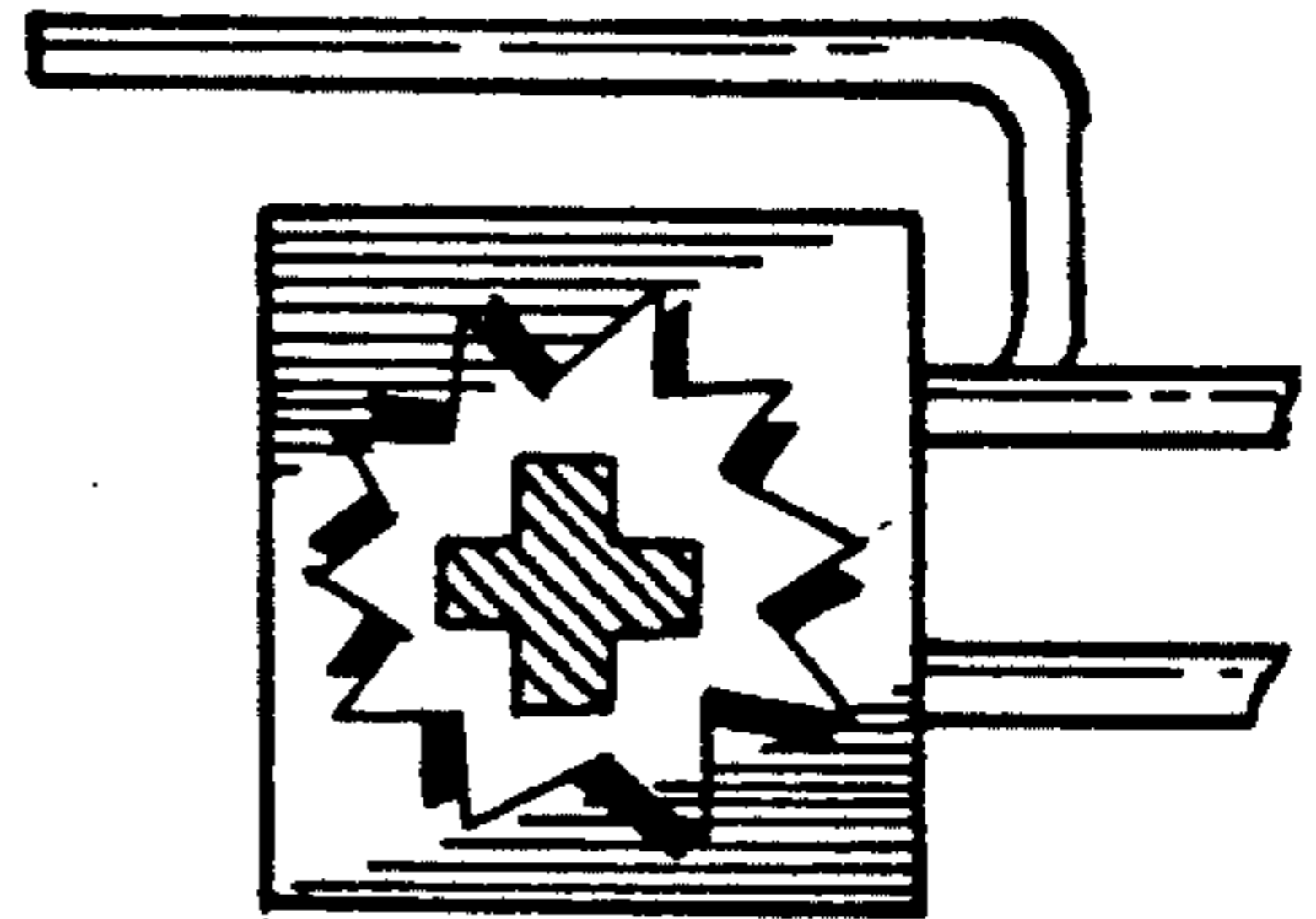

FIG. 9

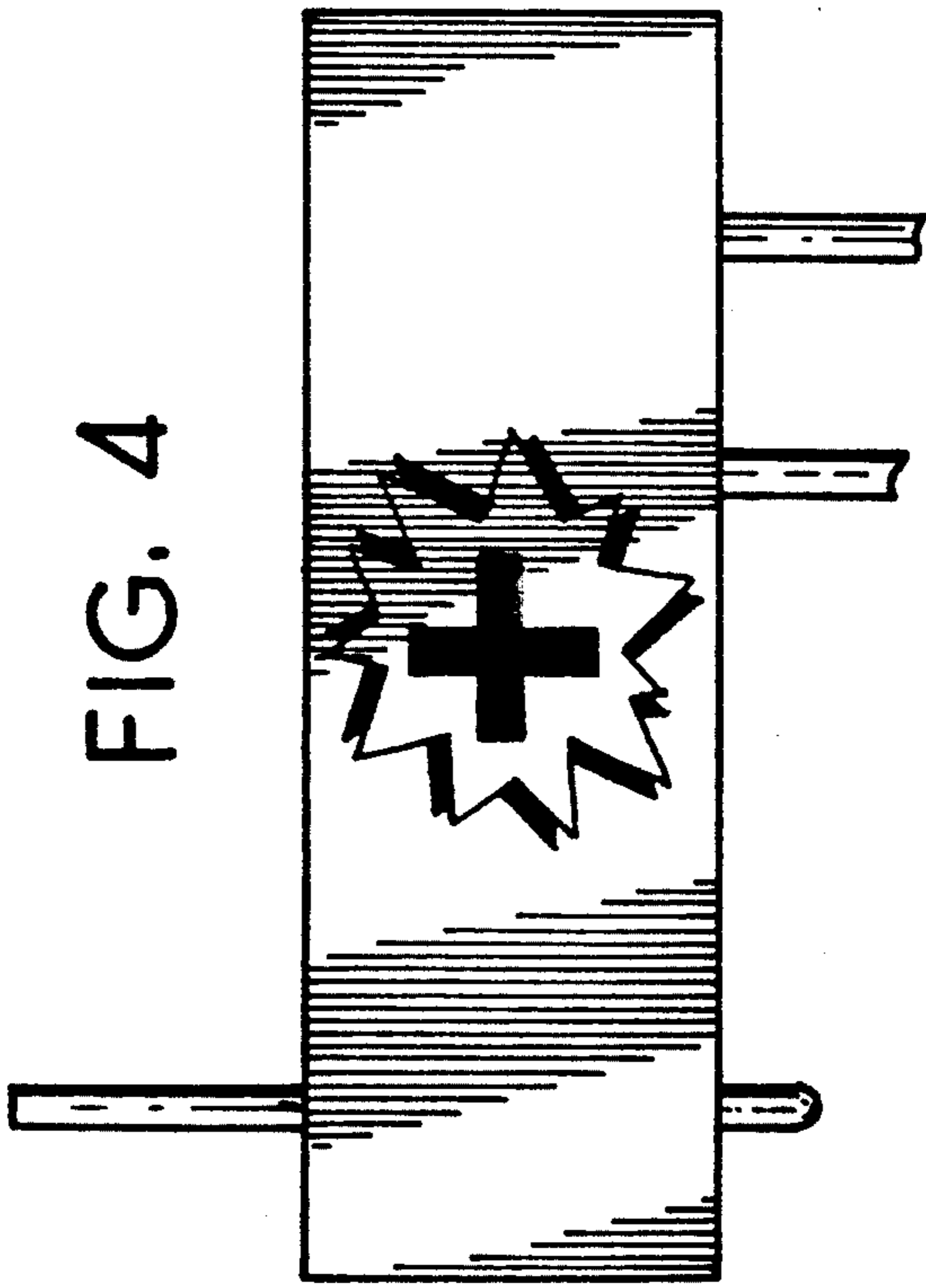

FIG. 4

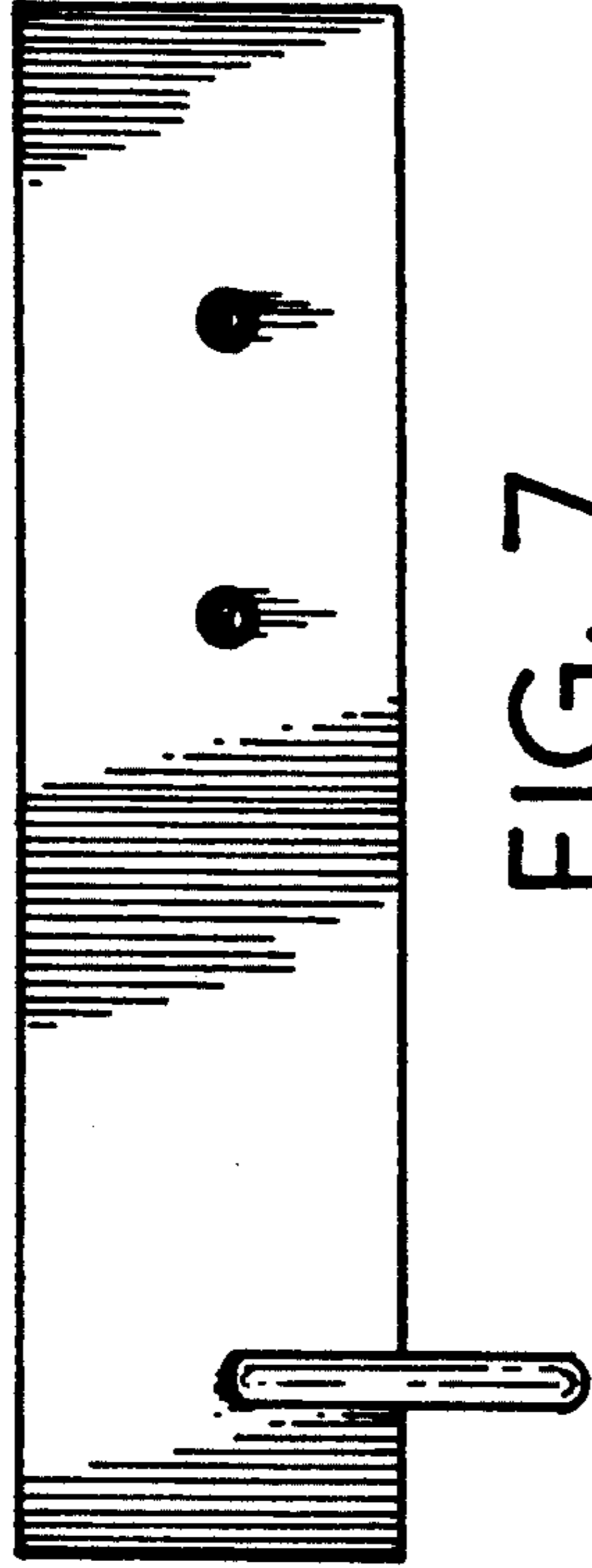

FIG. 7

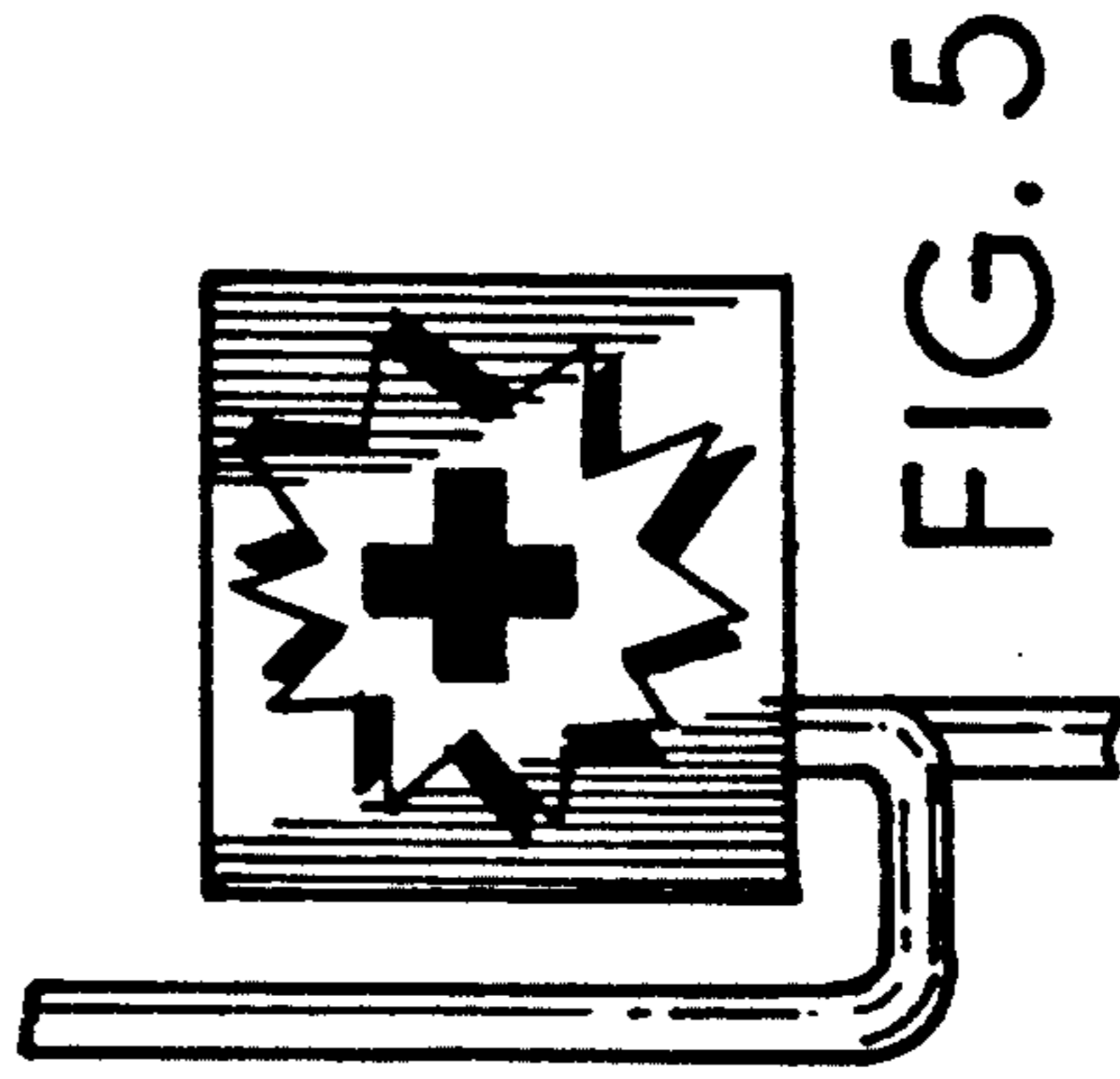

FIG. 5

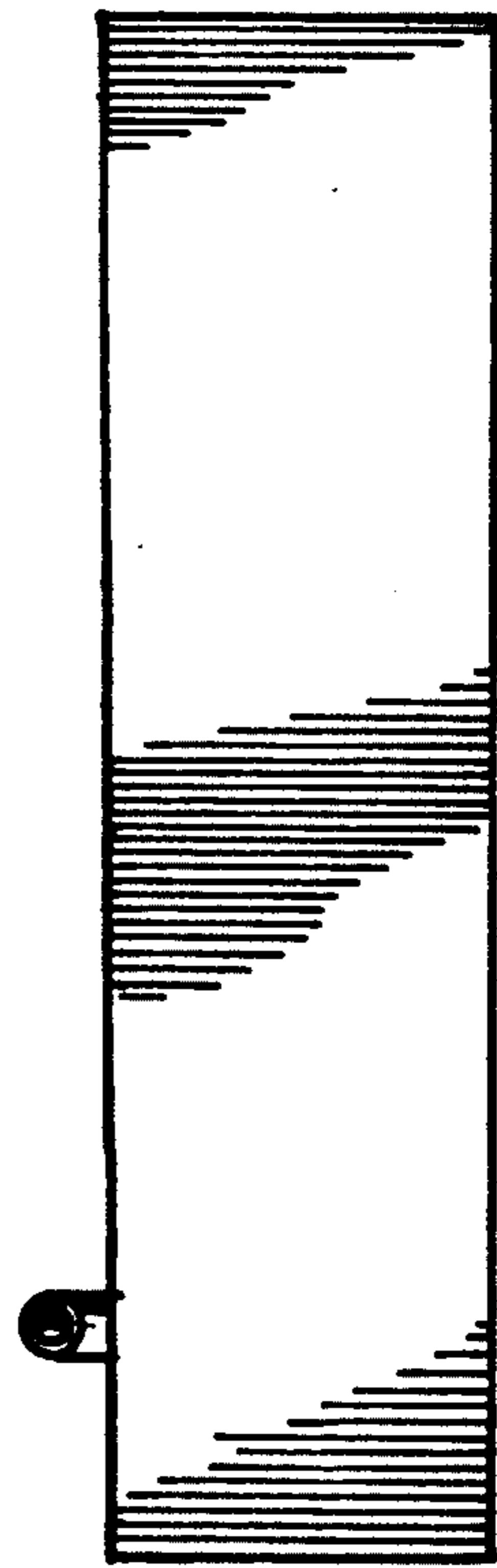

FIG. 6

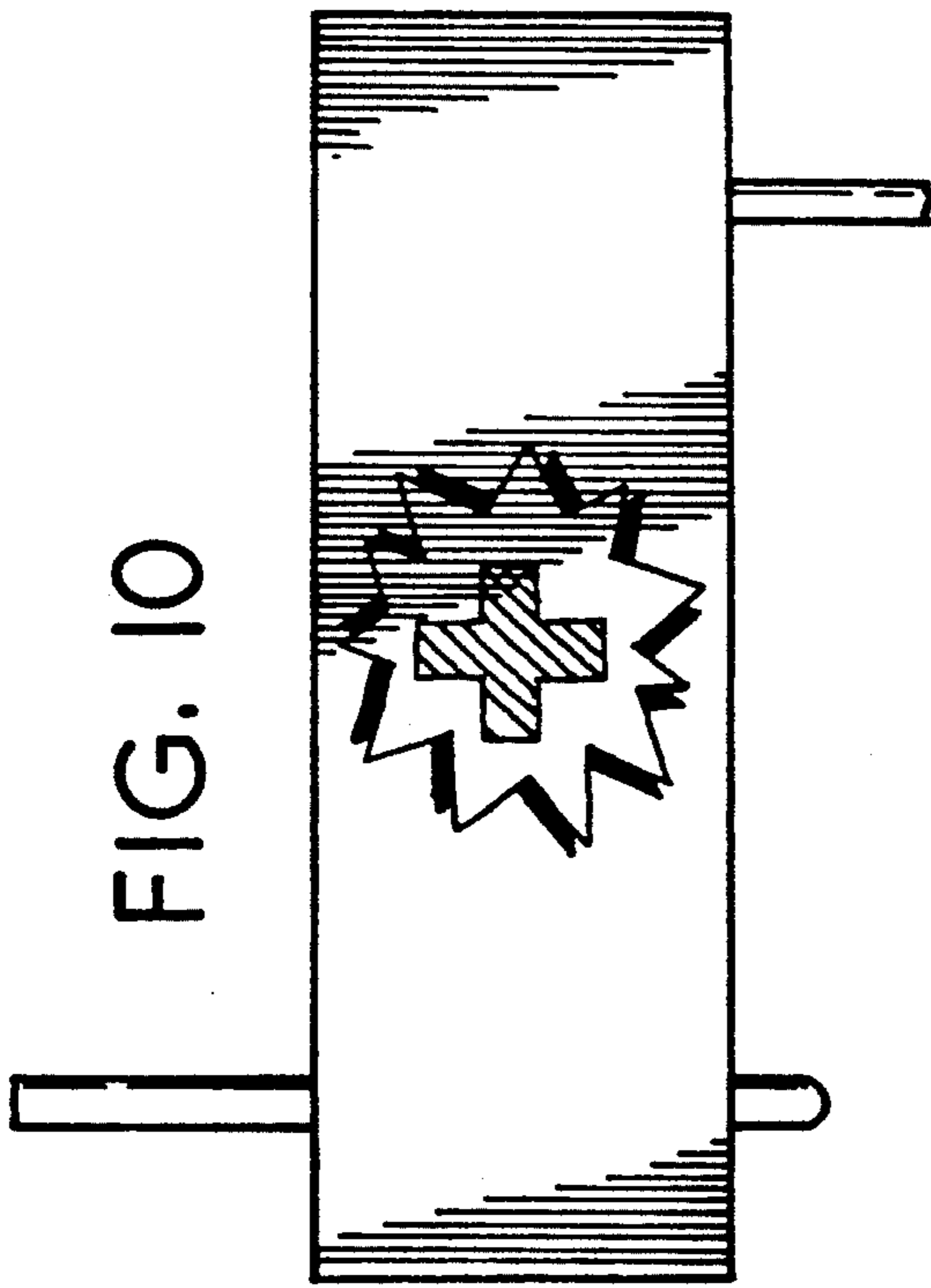

FIG. 10

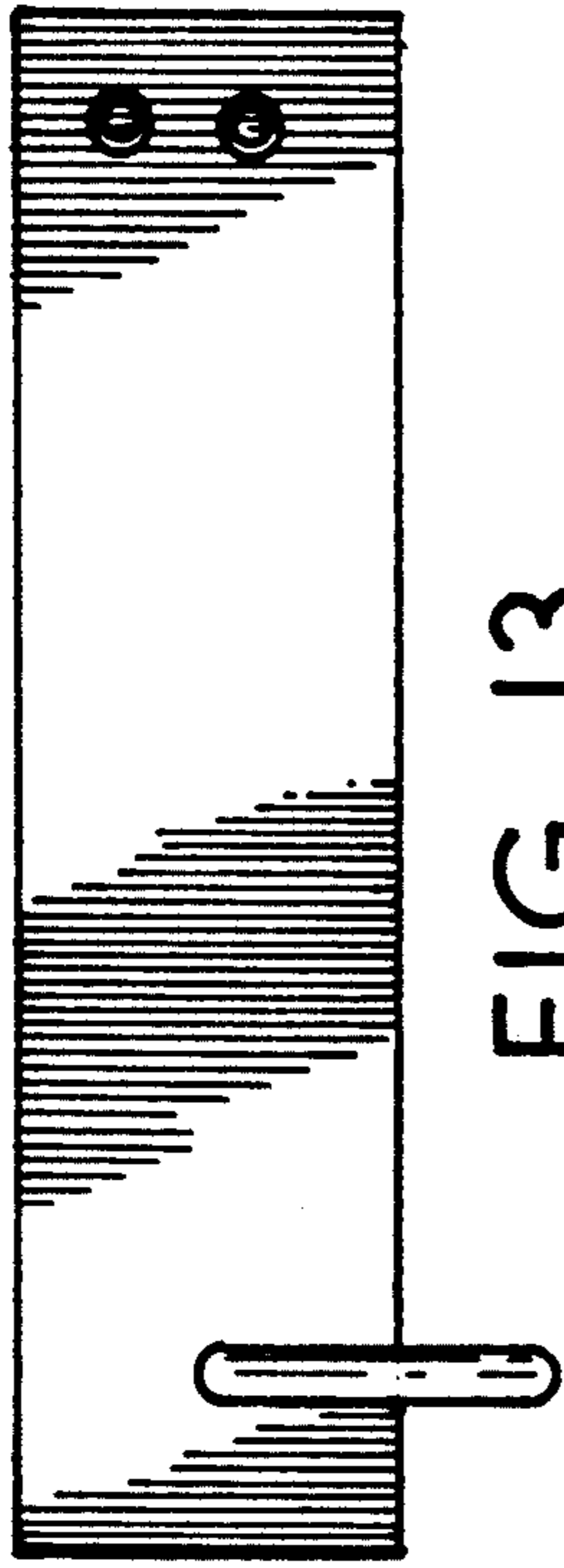

FIG. 13

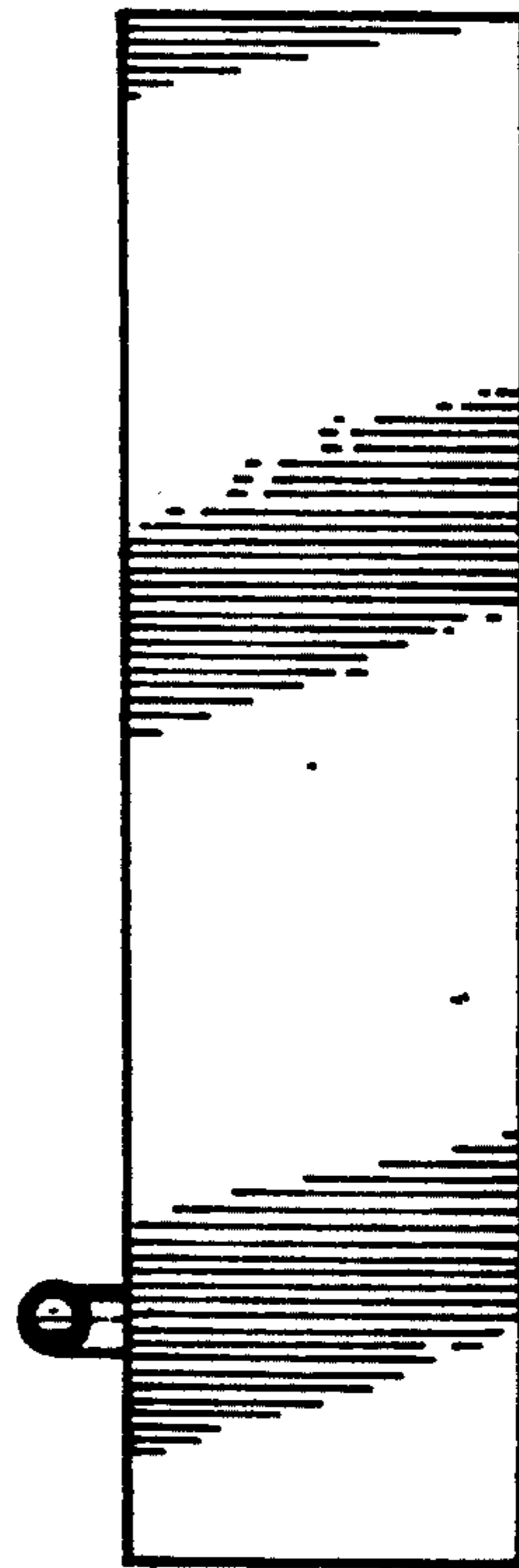

FIG. 12

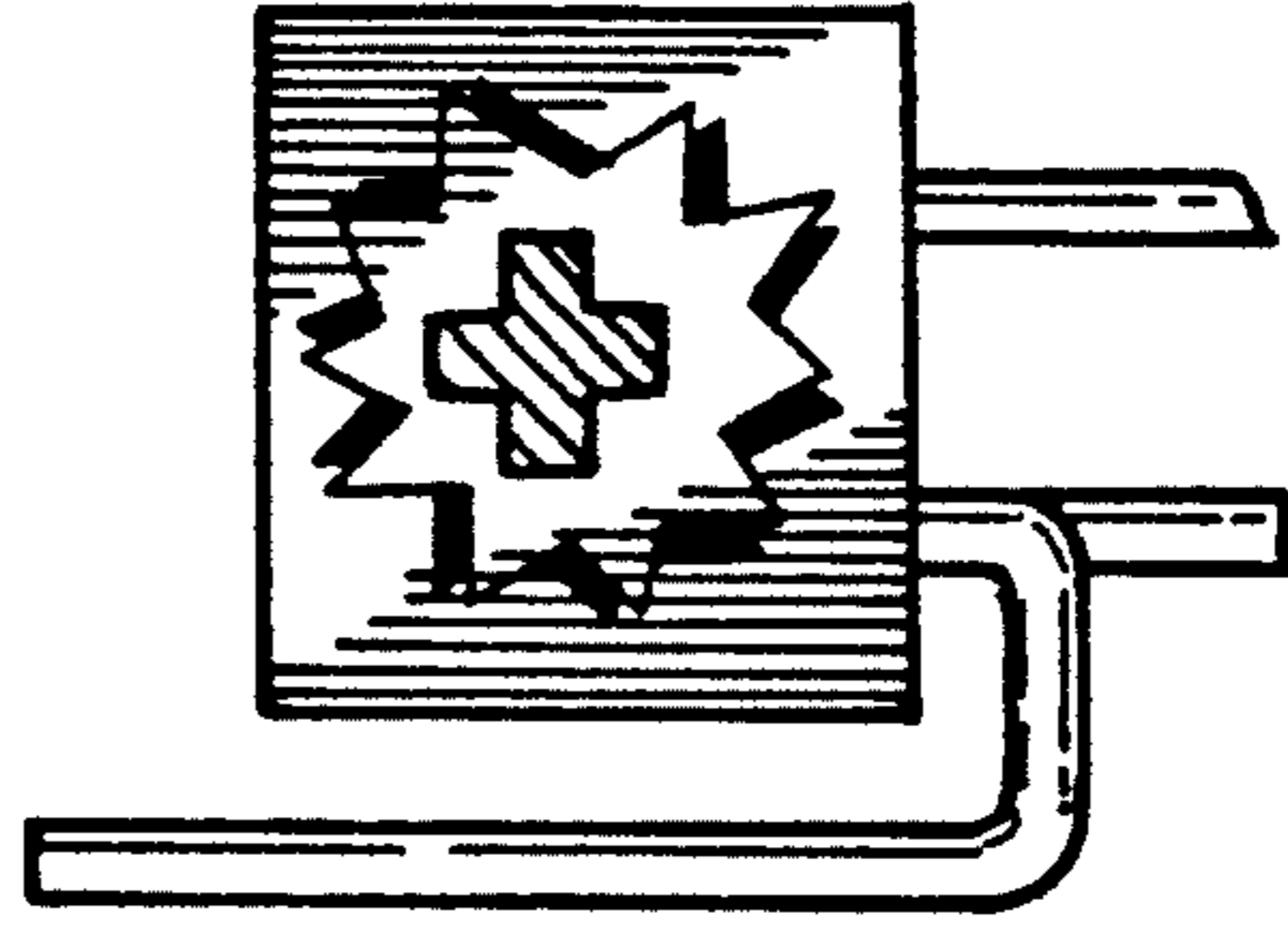

FIG. 11