



US00D336742S

United States Patent [19]

[11] Patent Number: Des. 336,742

Stewart

[45] Date of Patent: ** Jun. 22, 1993

[54] VEHICLE WHEEL

[75] Inventor: Charles H. Stewart, Clawson, Mich.

[73] Assignee: General Motors Corporation, Detroit, Mich.

[**] Term: 14 Years

[21] Appl. No.: 695,866

[22] Filed: May 6, 1991

[52] U.S. Cl. D12/211

[58] Field of Search D12/209, 211; 301/63 R, 301/63 PW, 64 R

[56] References Cited

U.S. PATENT DOCUMENTS

D. 267,564	1/1983	Wright	D12/211
D. 285,677	9/1986	Menking	D12/211

OTHER PUBLICATIONS

Motor Trend, Mar. 1990, p. 76, Wheel on Camaro Iroc-Z, top of page.

Motor Trend, Mar. 1990, p. 84, Wheel on Camaro Z28, top of page.

Road & Track, Oct. 1989, p. 59, Wheel on Mazdasports Miata, top right side of page.

Primary Examiner—James M. Gandy

Attorney, Agent, or Firm—Herbert Furman

[57] CLAIM

The ornamental design for a vehicle wheel, as shown.

DESCRIPTION

FIG. 1 is a front elevational view of a vehicle wheel showing my new design;

FIG. 2 is a sectional view taken along line 2—2 of FIG. 1; and,

FIG. 3 is an enlarged fragmentary sectional view taken along line 3—3 of FIG. 1.

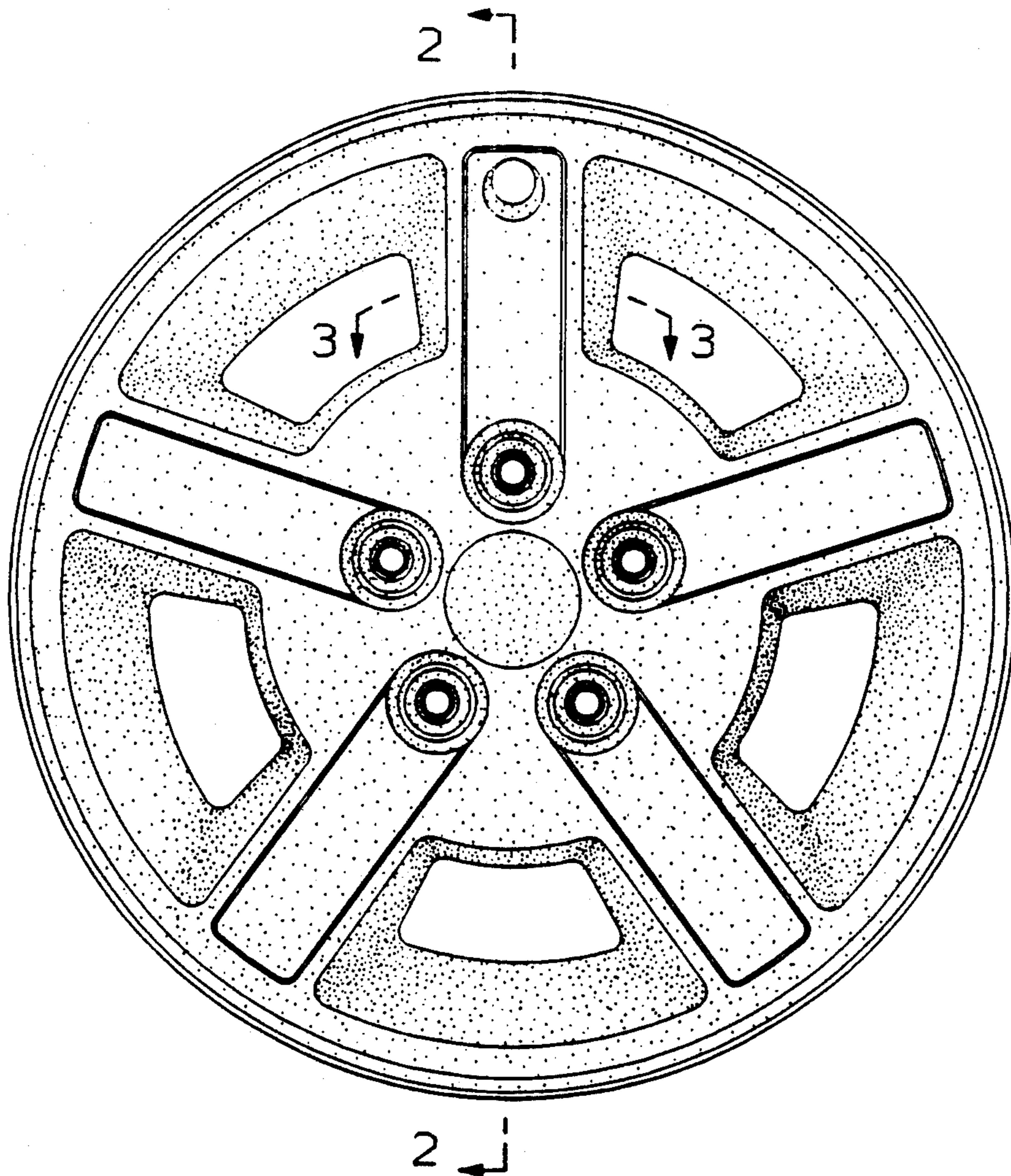

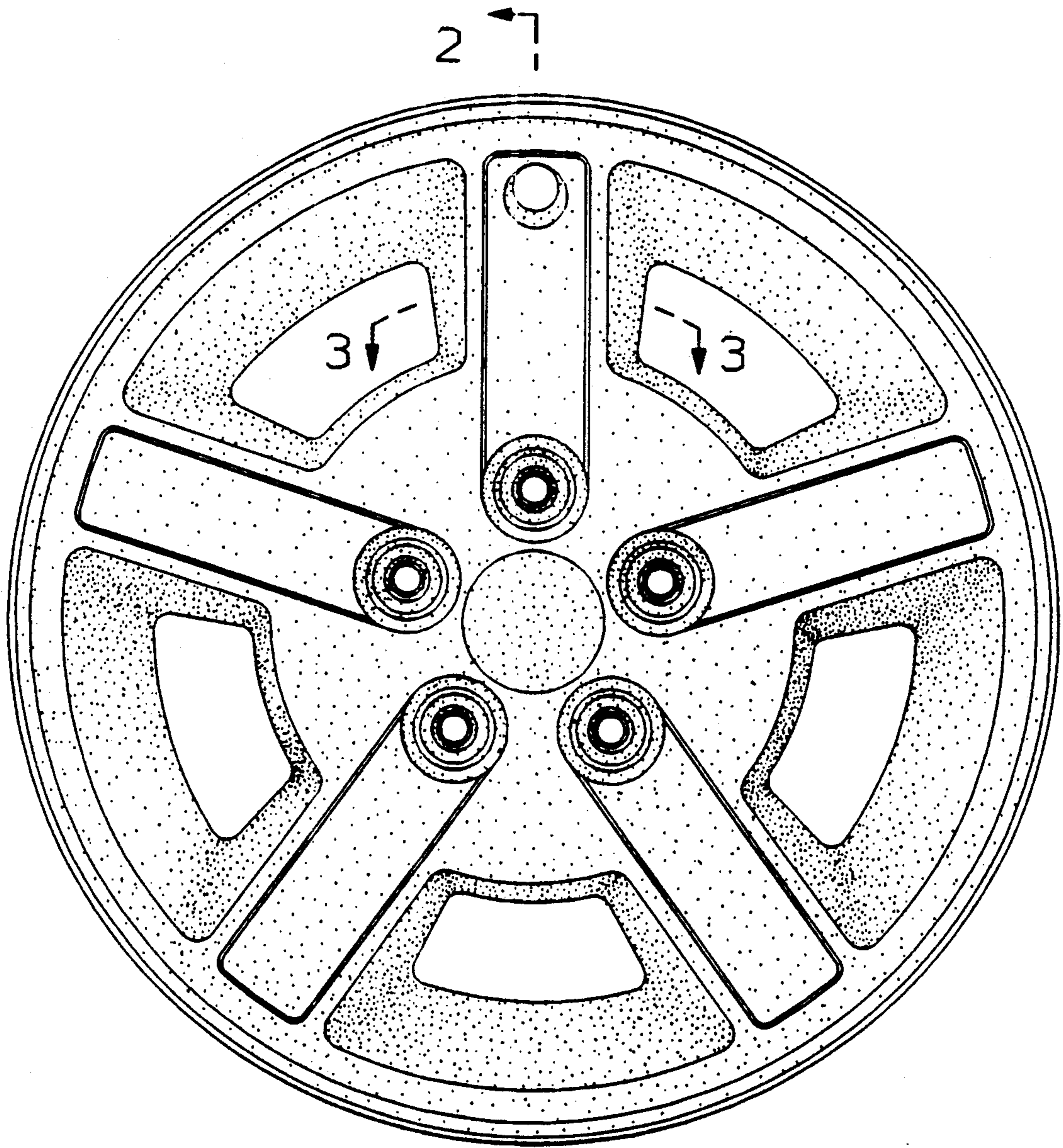

2 ↙
2 ↘
FIG. 1

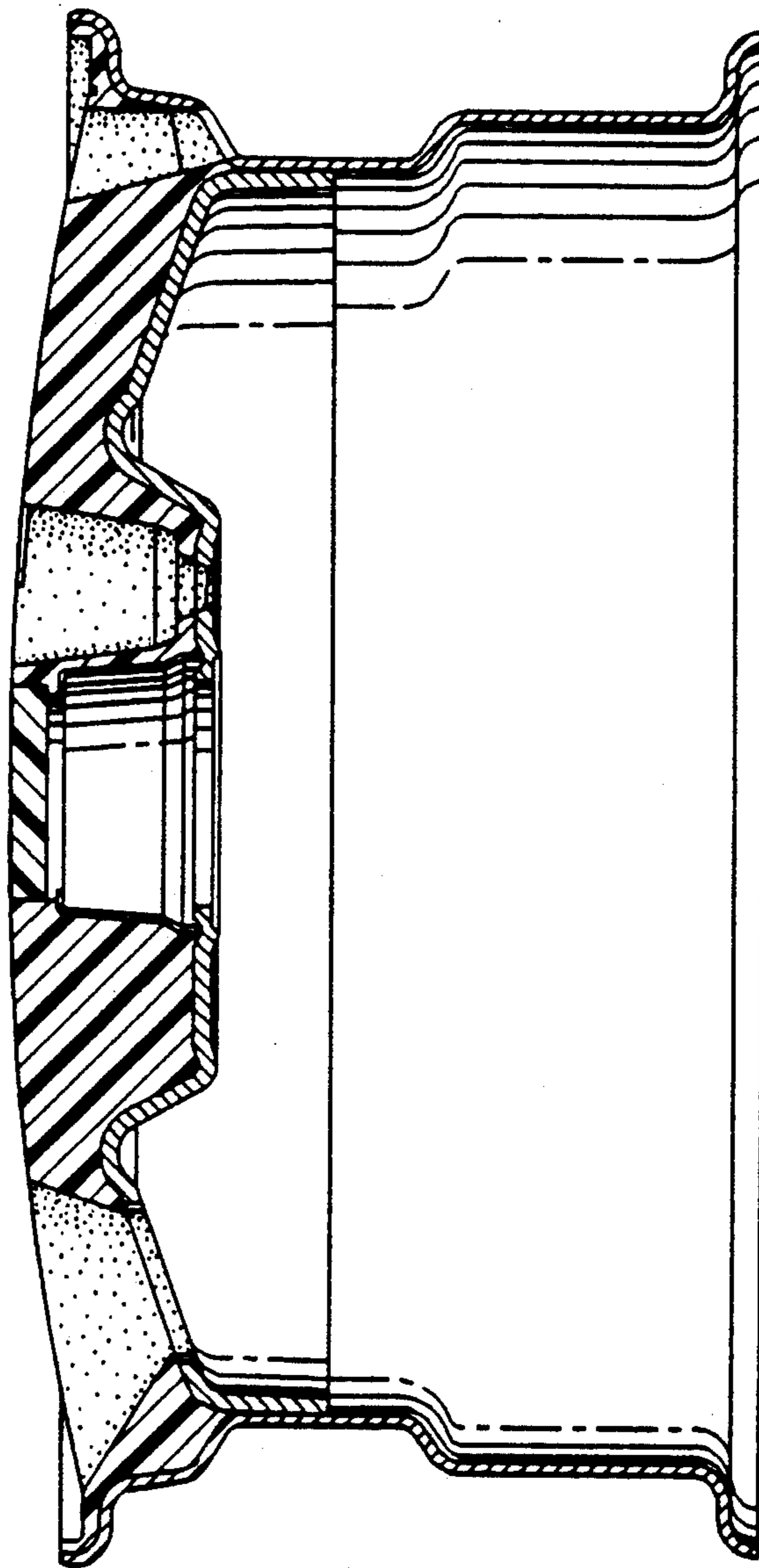

FIG. 2

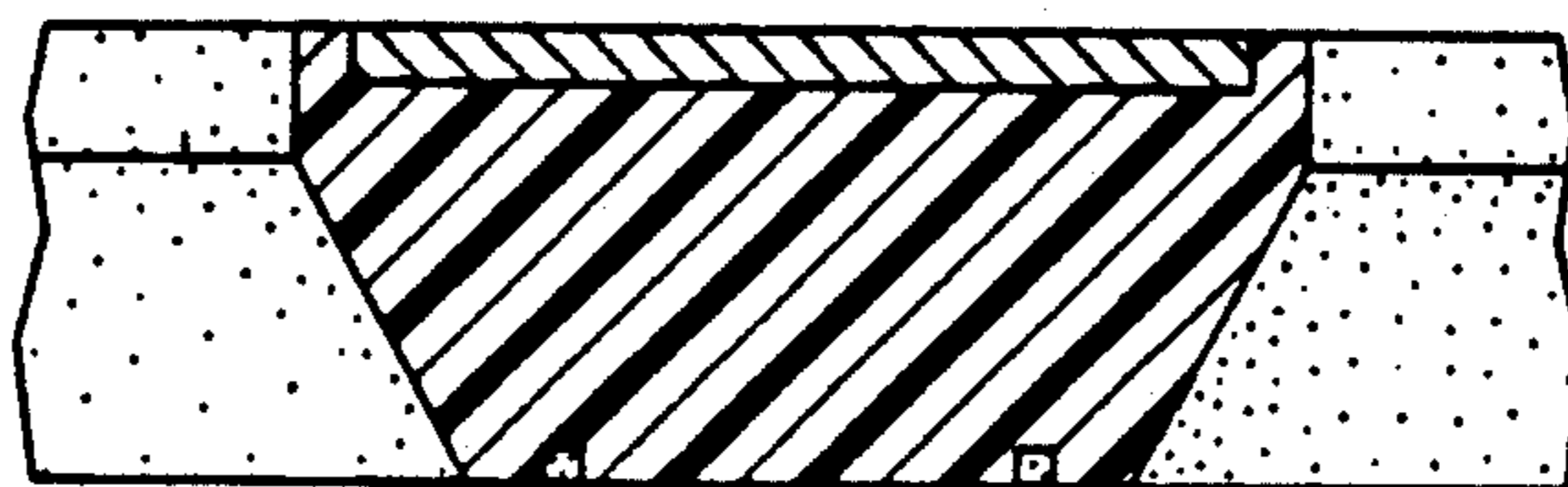

FIG. 3