



US00D336737S

United States Patent [19]

Cannara

[11] Patent Number: Des. 336,737

[45] Date of Patent: ** Jun. 22, 1993

[54] AUTOMOTIVE VEHICLE

[75] Inventor: **Raymond C. Cannara**, Clarkston, Mich.

[73] Assignee: **Chrysler Corporation**, Highland Park, Mich.

[**] Term: **14 Years**

[21] Appl. No.: **766,167**

[22] Filed: **Sep. 26, 1991**

[52] U.S. Cl. **D12/91**

[58] Field of Search **D12/90-92;**
296/185

[56] **References Cited**
PUBLICATIONS

Car & Driver, Mar./1990, p. 58, Toyota Land Cruiser, Lower Left Center of Page.

Popular Mechanics, Apr./1989, p. 72, Jeep Concept I Vehicle, Bottom of Page.

New York Times, Mar. 31, 1991, p. 185, Jeep Wagoneer 2000, Fourth Vehicle Up From Bottom of Page.

Primary Examiner—James M. Gandy
Attorney, Agent, or Firm—Mark P. Calcaterra

[57] **CLAIM**

The ornamental design for an automotive vehicle, as shown and described.

DESCRIPTION

FIG. 1 is a front perspective view of an automotive vehicle embodying the design;

FIG. 2 is a left side elevational view thereof;

FIG. 3 is a right side elevational view thereof;

FIG. 4 is a rear elevational view thereof;

FIG. 5 is a front elevational view thereof; and,

FIG. 6 is a rear perspective view thereof.

The top of the automotive vehicle is understood to be plain and unornamented.

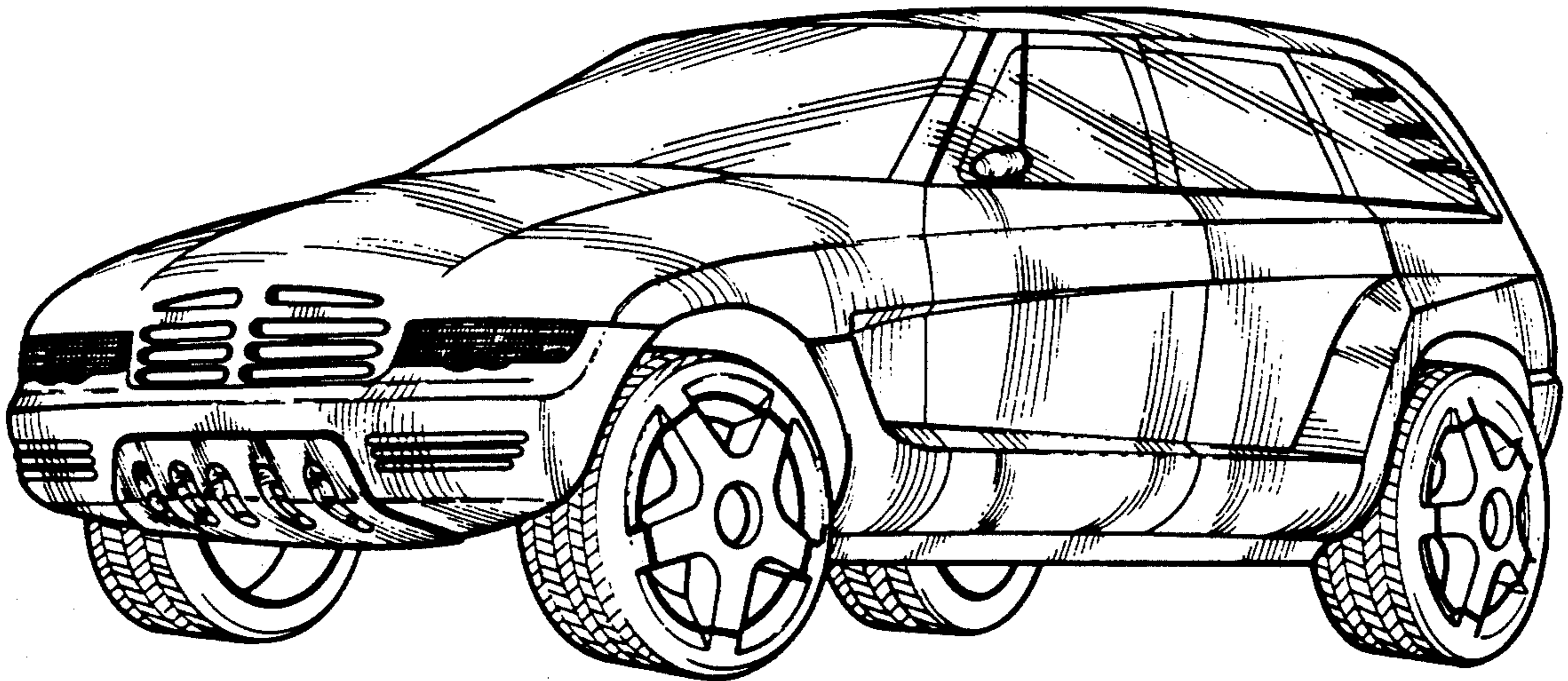

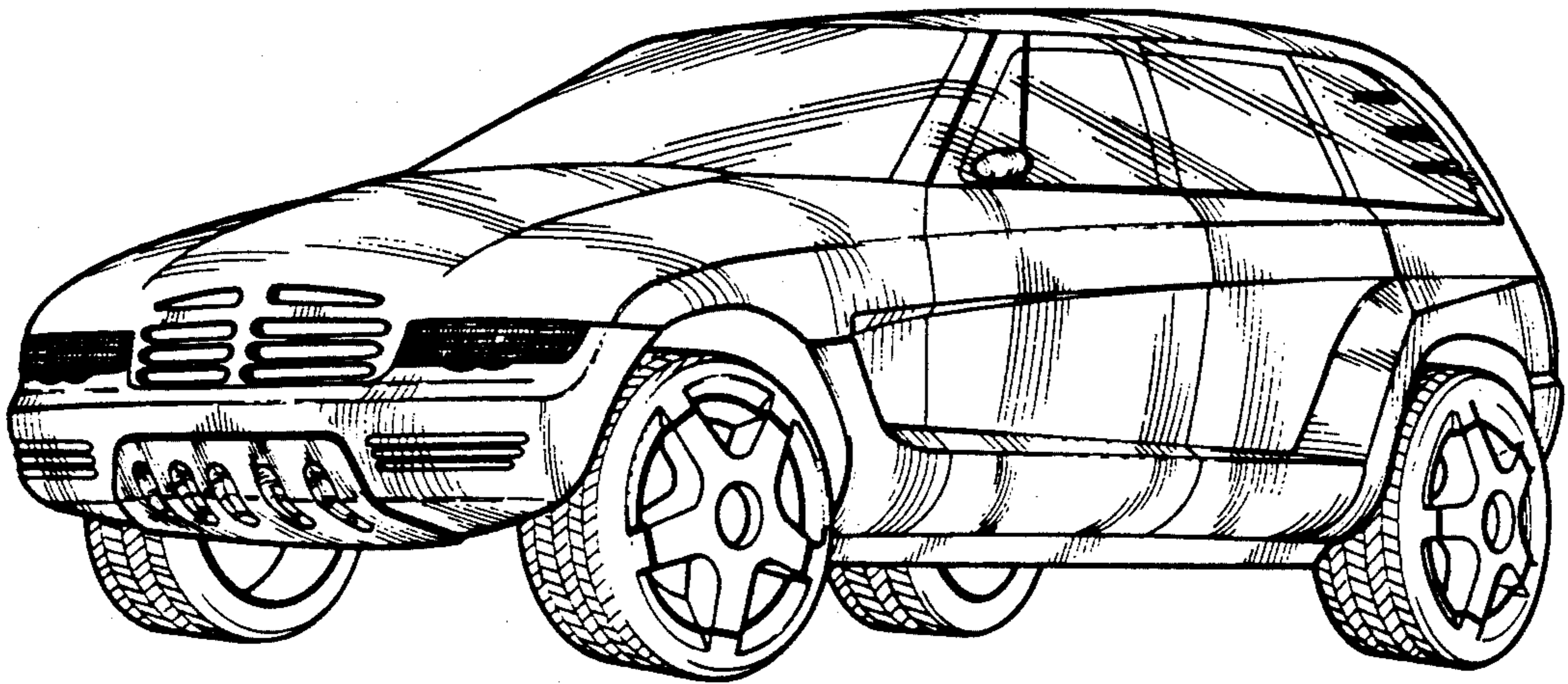

Fig-1

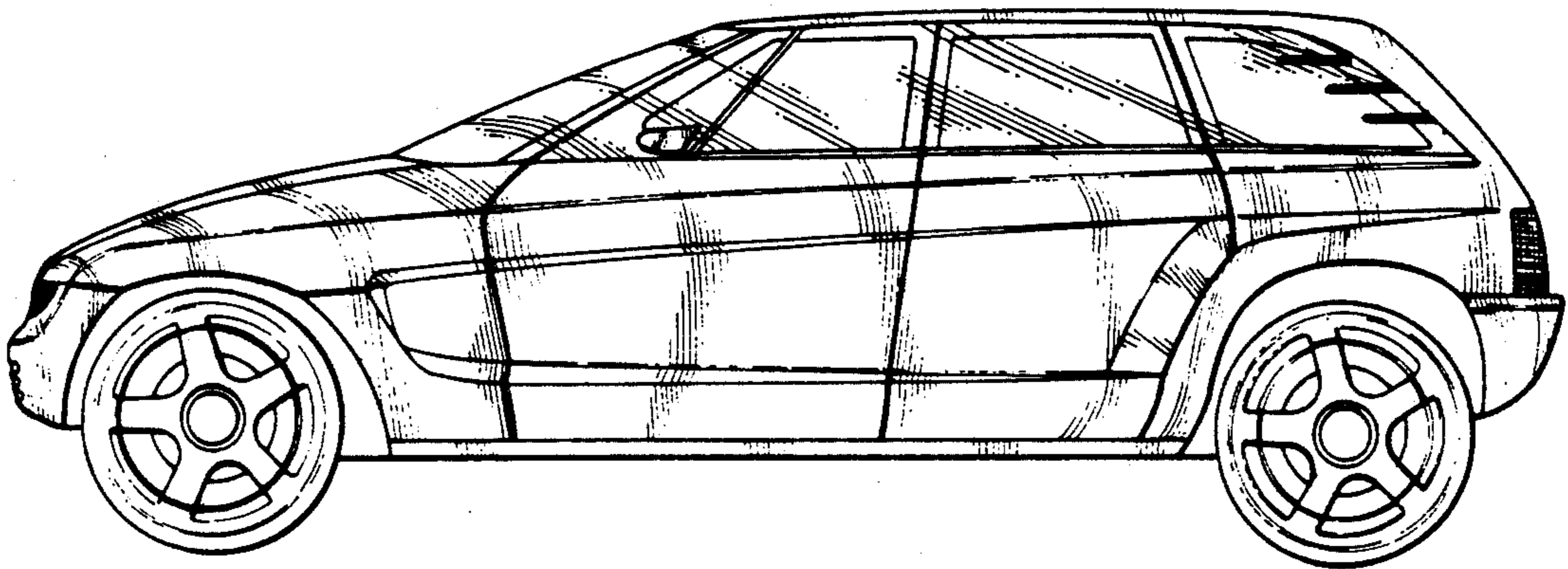

Fig-2

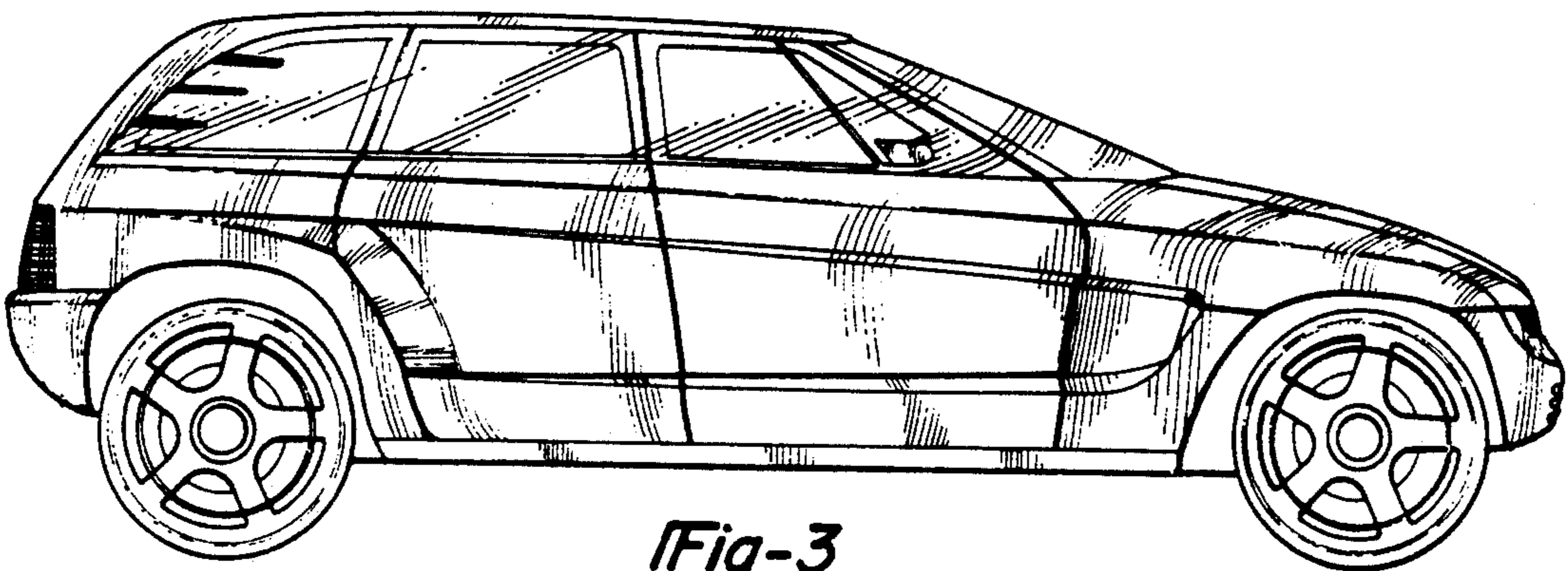

Fig-3

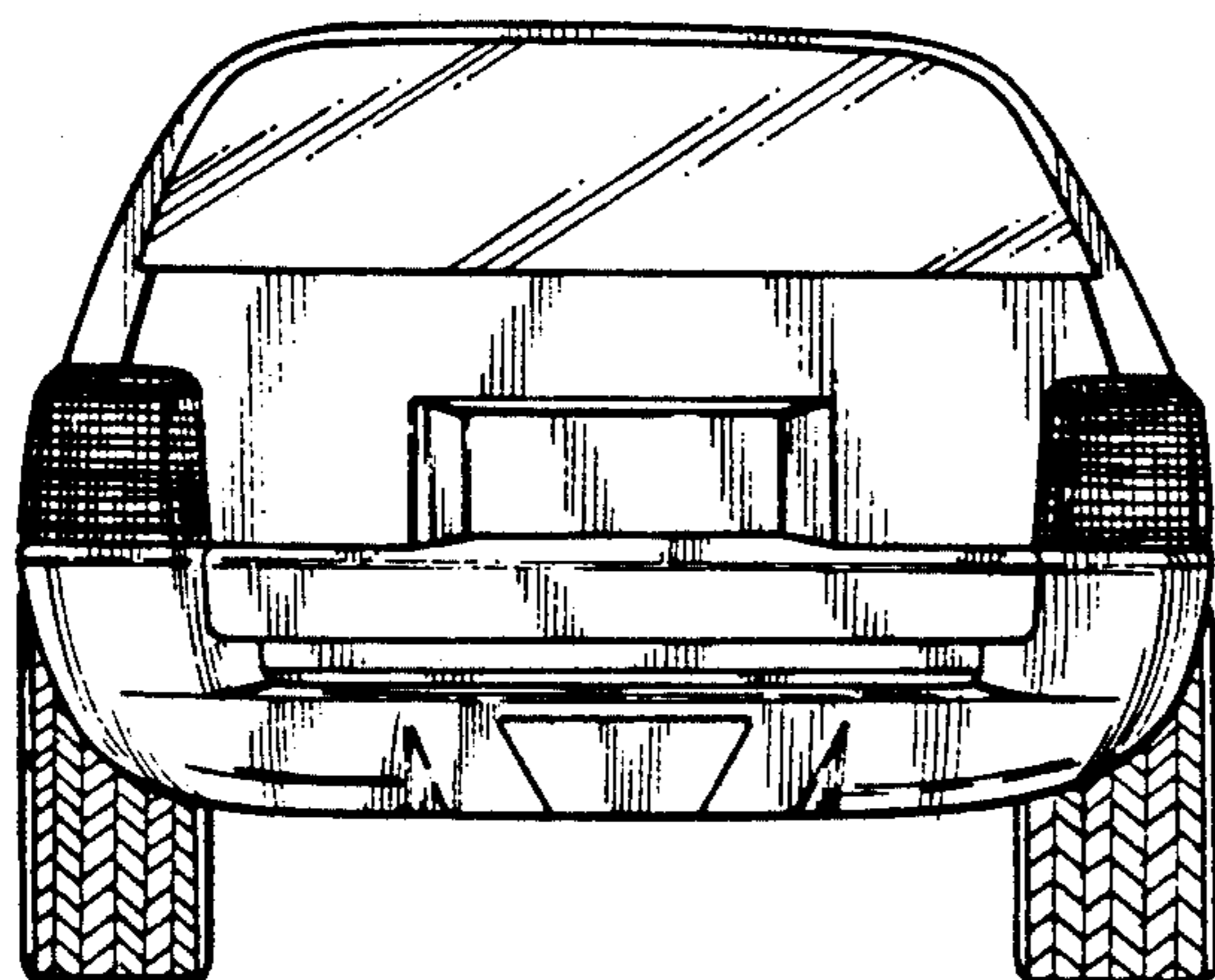

Fig-4

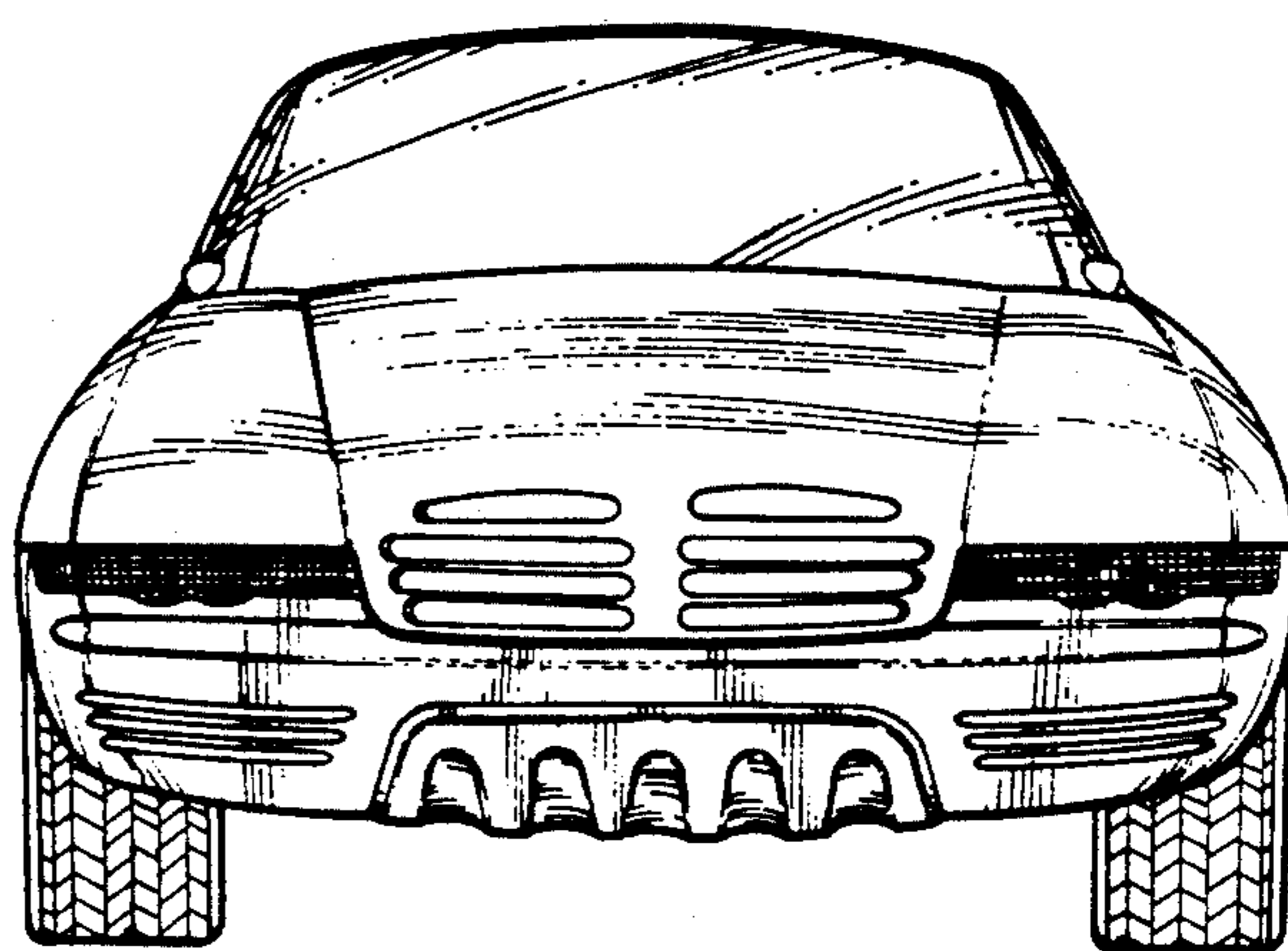

Fig-5

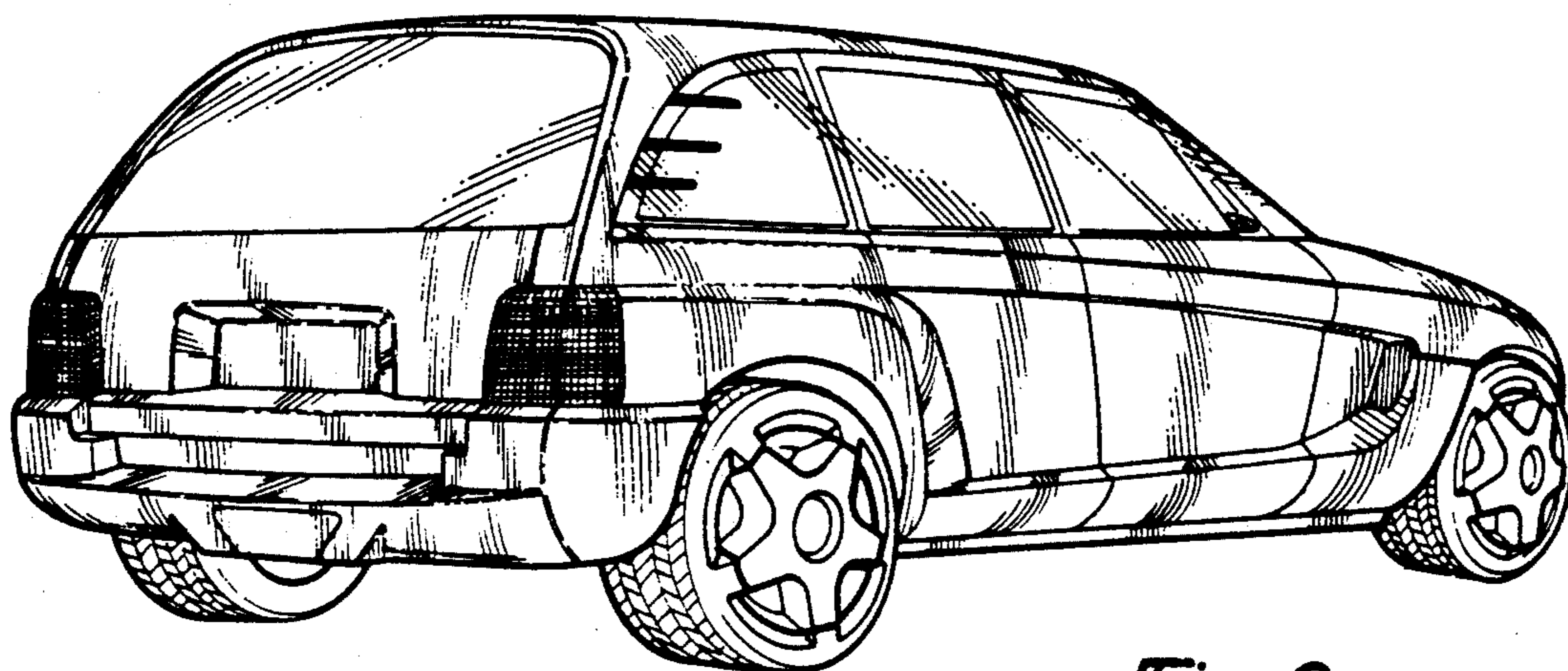

Fig-6