



US00D336293S

United States Patent [19]

[11] Patent Number: **Des. 336,293**

Morano

[45] Date of Patent: **** Jun. 8, 1993**

[54] **ADAPTER UNIT FOR PROVIDING A CORDLESS CONNECTION BETWEEN THE HANDSET AND BASE OF A TELEPHONE**

[76] Inventor: **Michael Morano, 1185 Moss Mill Rd., Hammonton, N.J. 08037**

[**] Term: **14 Years**

[21] Appl. No.: **584,883**

[22] Filed: **Sep. 19, 1990**

[52] U.S. Cl. **D14/140; D14/240; D14/251; /**

[58] Field of Search **D14/138, 250, 252, 142, D14/251; D12/155; 379/438, 428, 454; 455/90, 349**

D. 298,129	10/1988	Watanab	D14/138
D. 301,473	6/1989	Rojc	D14/251
D. 315,161	3/1991	Watanabe	D14/142
D. 320,991	10/1991	Nagai et al.	D14/251
4,053,717	10/1977	Snider	179/41 A
4,332,981	6/1982	Palombi	179/25 A
4,546,217	10/1985	Frehn	D14/250 X
4,585,903	4/1986	Schiller	179/25 A

Primary Examiner—James M. Gandy
Attorney, Agent, or Firm—Terry M. Gernstein

[57] CLAIM

The ornamental design for an adapter unit for providing a cordless connection between the handset and base of a telephone, as shown and described.

DESCRIPTION

FIG. 1 is a perspective view of the adapter unit for providing a cordless connection between the handset and base of a telephone embodying the design of the present invention;
FIG. 2 is a front elevational view thereof, the rear being a mirror image of the front shown in FIG. 2;
FIG. 3 is an end elevational view thereof;
FIG. 4 is an opposite end elevational view thereof;
FIG. 5 is a top plan view thereof; and,
FIG. 6 is a bottom view thereof.

[56] References Cited

U.S. PATENT DOCUMENTS

D. 142,873	11/1945	Knorr	D14/138
D. 157,120	2/1950	Backie	D14/252
D. 193,431	8/1962	Newton	D14/252
D. 203,831	2/1966	Chipping	D14/138
D. 211,999	8/1968	Prince	D19/252
D. 263,706	4/1982	Fukushima	D14/138
D. 284,372	6/1986	Carpenter	D14/250 X
D. 294,827	3/1988	Woodfork	D14/250
D. 295,170	4/1988	Wolstone	D14/138

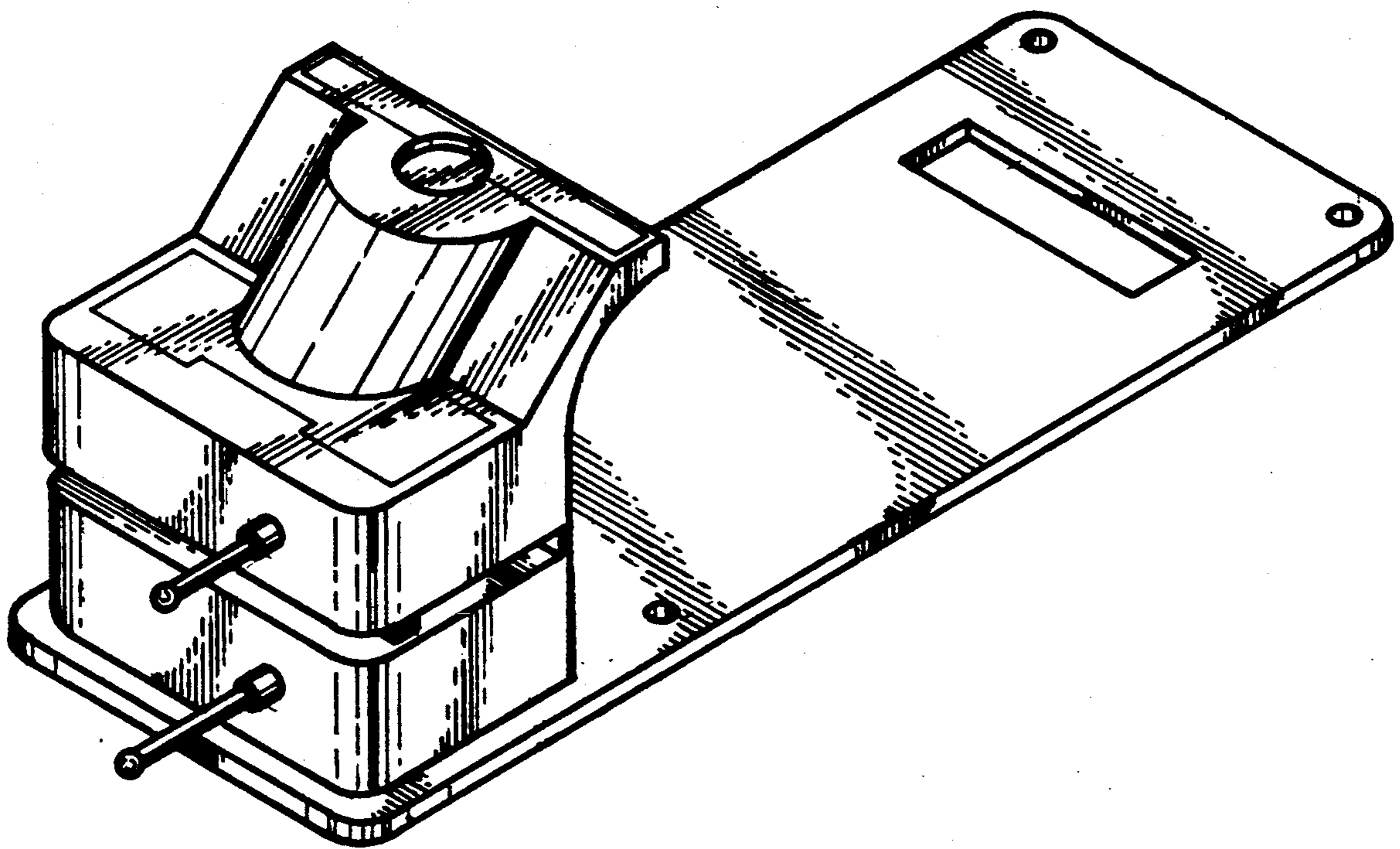

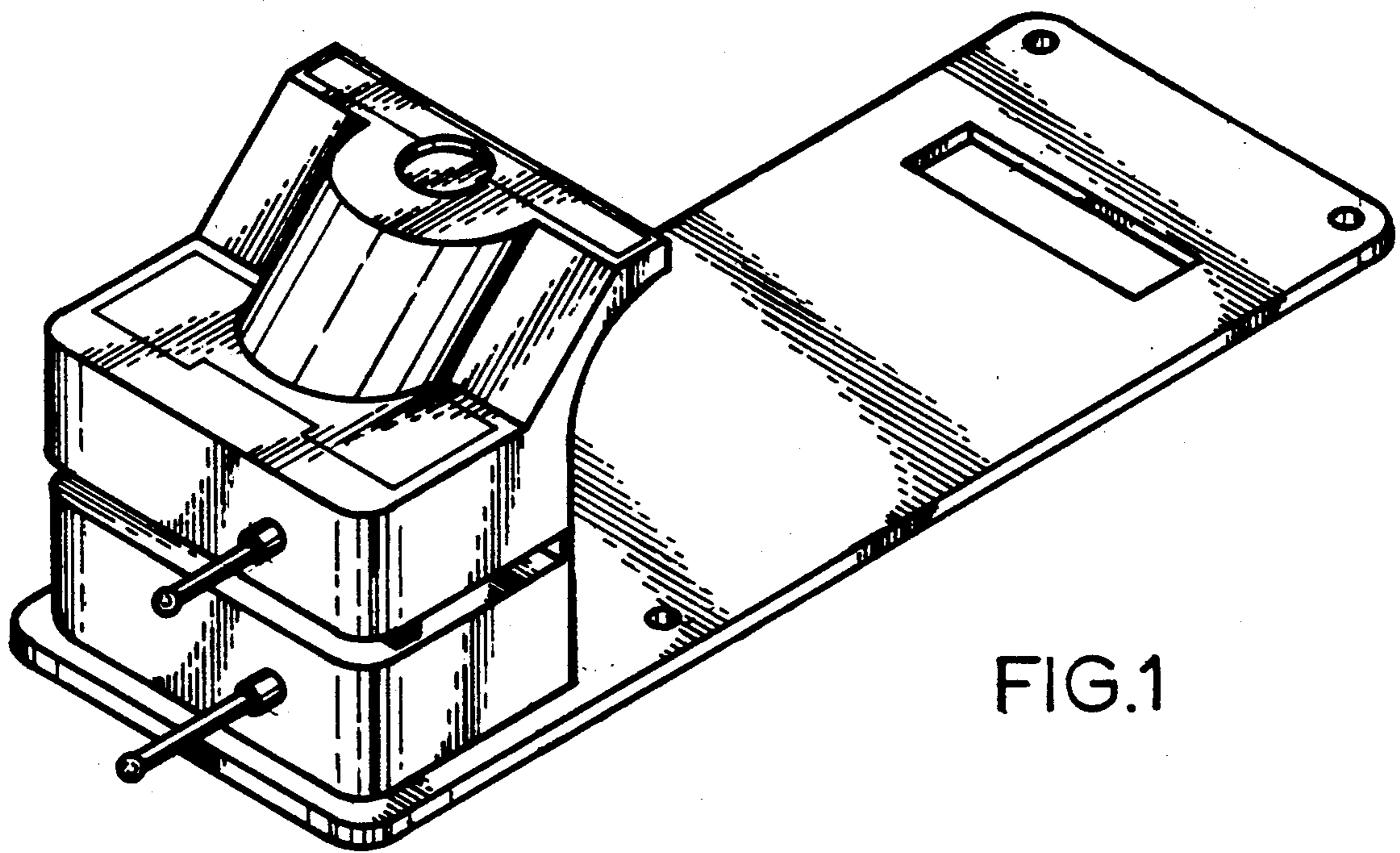

FIG.1

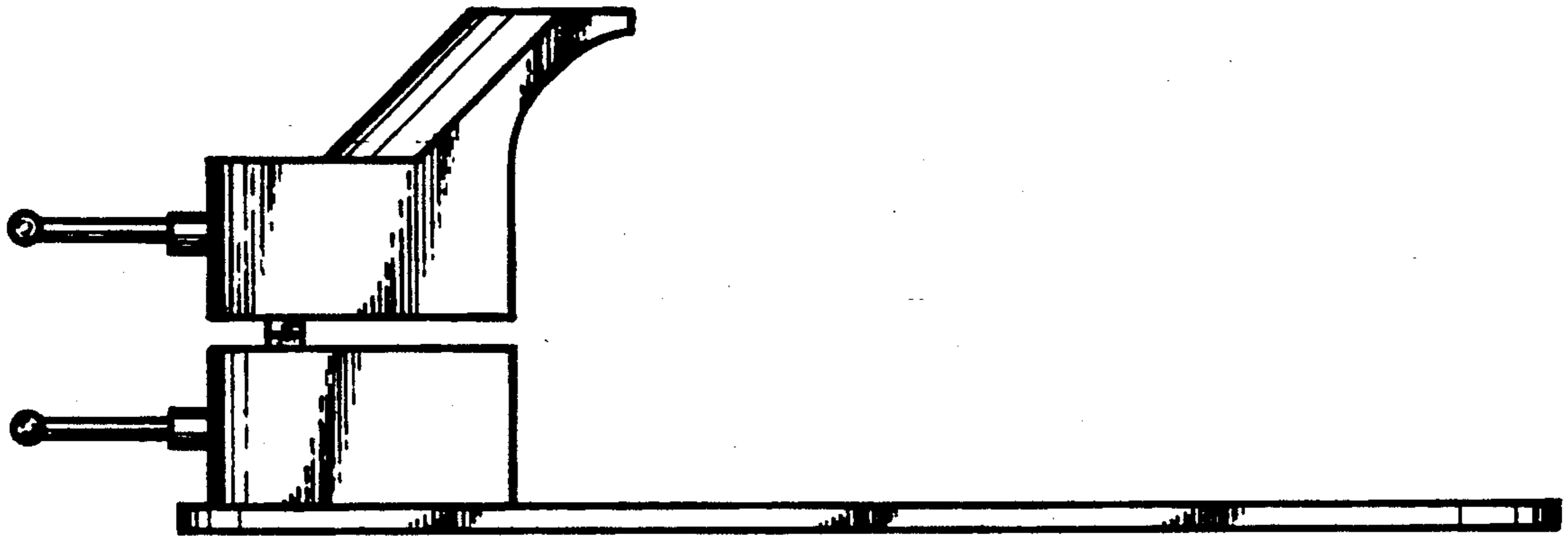

FIG. 2

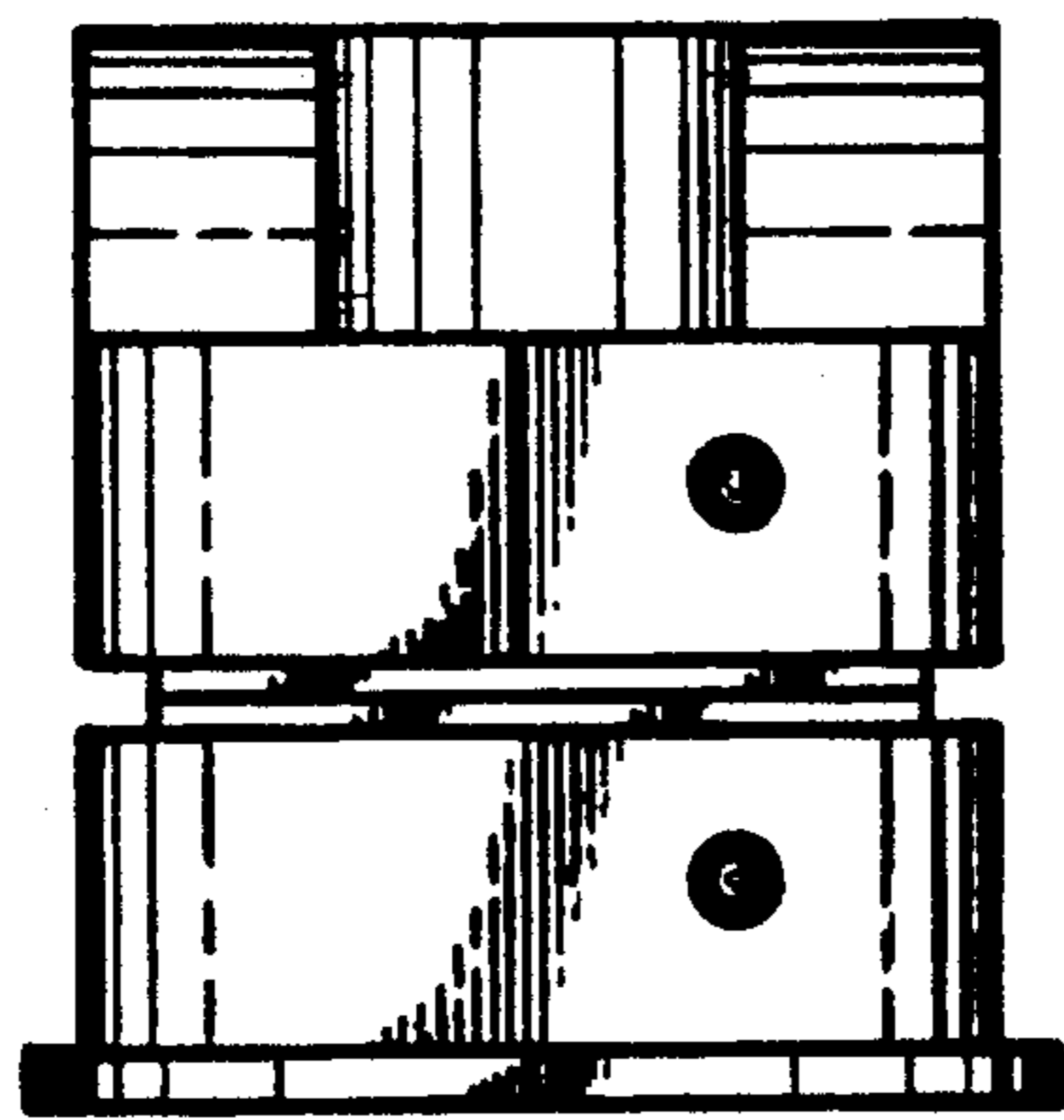

FIG. 3

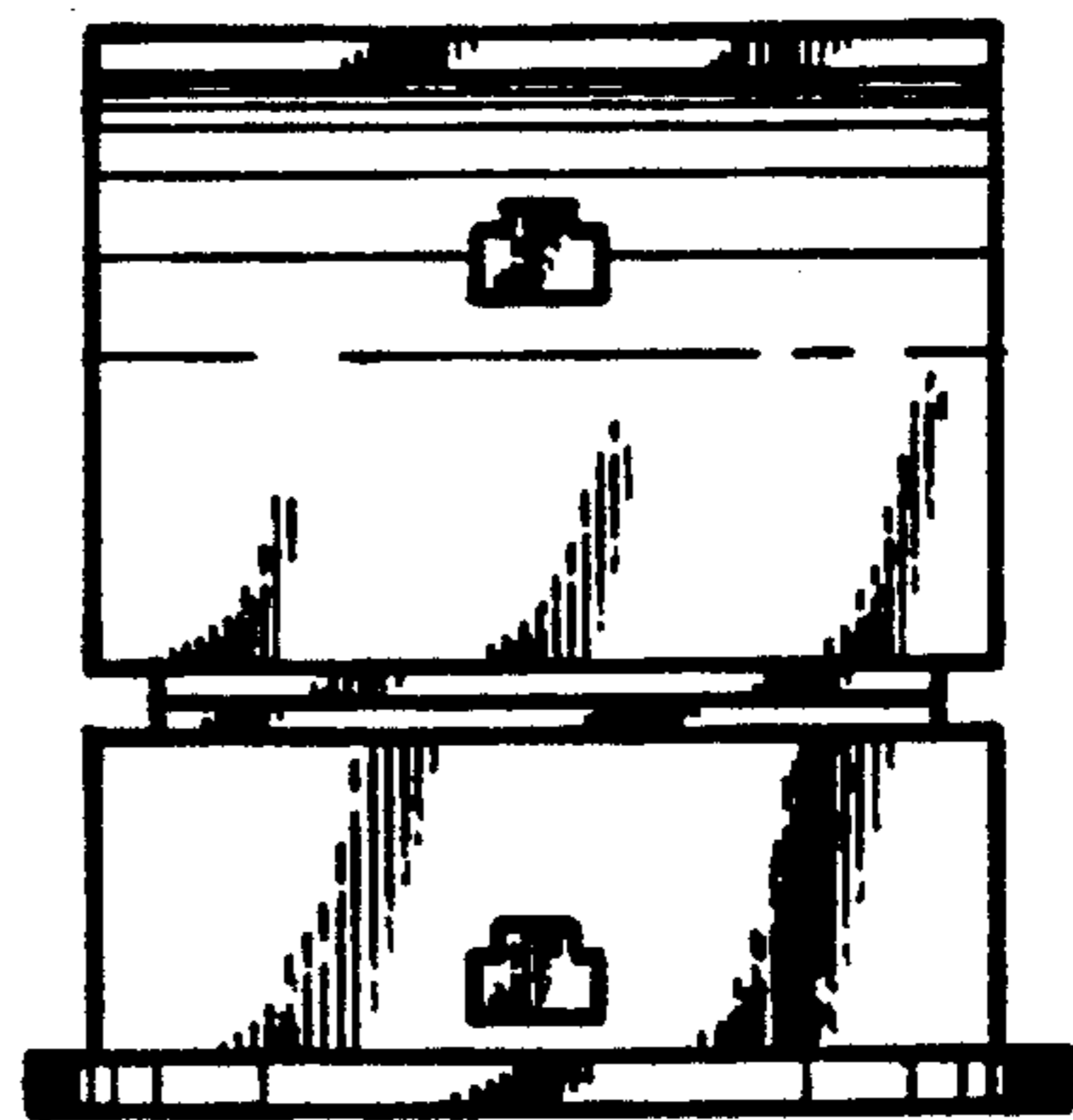

FIG. 4

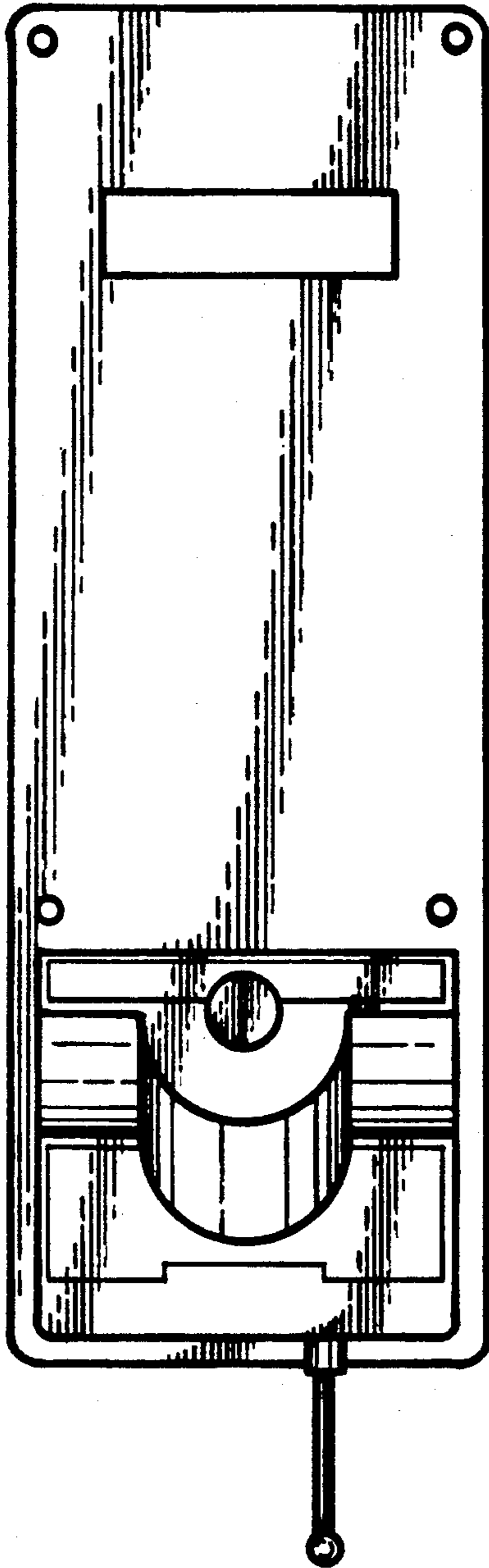

FIG. 5

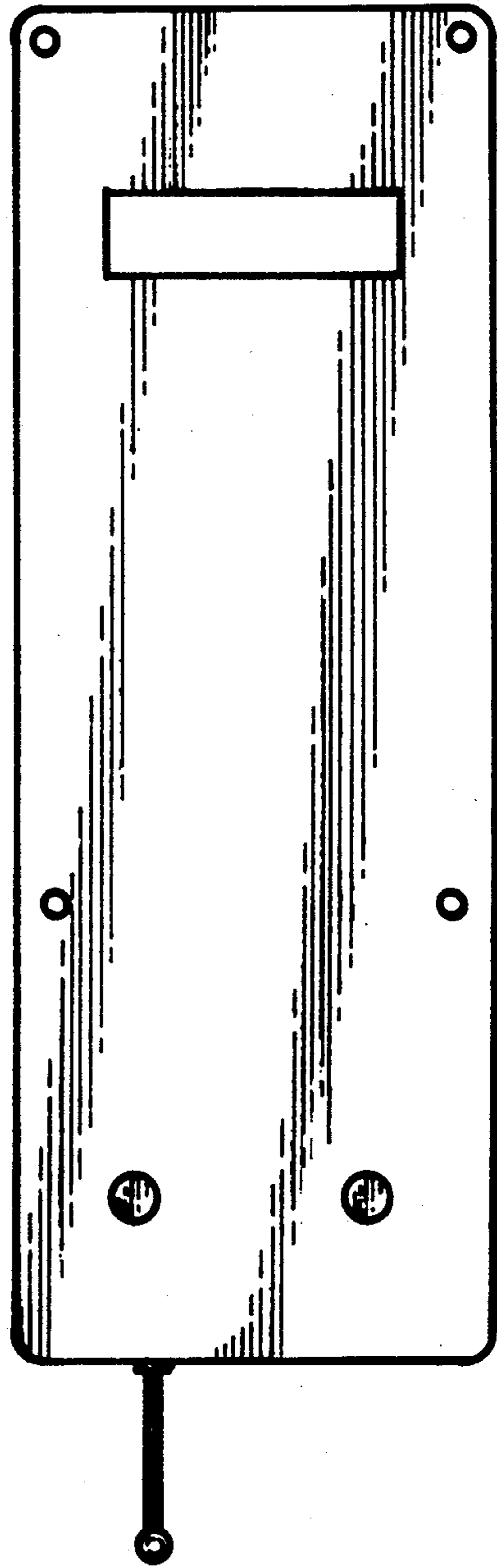

FIG. 6