



US00D336235S

United States Patent [19]

Nickerson

[11] Patent Number: **Des. 336,235**

[45] Date of Patent: **** Jun. 8, 1993**

[54] **QUICK RELEASE HINGE FOR AN
AUTOMOBILE ENGINE HOOD**

4,727,621	3/1988	Emery et al.	180/69.21
4,839,941	6/1989	Orlando	180/69.21
4,991,675	2/1991	Tosconi et al.	180/69.21

[76] Inventor: **Lenley S. Nickerson, 1800 Floyd Ave., Modesto, Calif. 95355**

Primary Examiner—B. J. Bullock
Attorney, Agent, or Firm—Lothrop & West

[**] Term: **14 Years**

[57] **CLAIM**

[21] Appl. No.: **503,570**

The ornamental design for a quick release hinge for an automobile engine hood, as shown.

[22] Filed: **Apr. 3, 1990**

DESCRIPTION

[52] U.S. Cl. **D8/327**

[58] Field of Search **D8/323, 327; 16/387;**
180/69.2, 69.21

FIG. 1 is a left, front perspective view of a quick release hinge for an automobile engine hood, showing my new design;

[56] References Cited

U.S. PATENT DOCUMENTS

3,815,176	6/1974	Porter	180/69.21
4,206,944	6/1910	Kumagai	180/69.21
4,366,598	1/1983	Harasaki et al.	180/69.21
4,382,312	5/1983	Liggett et al.	180/69.21

FIG. 2 is a top plan view, thereof;

FIG. 3 is a bottom plan view, thereof;

FIG. 4 is a left side elevational view, thereof;

FIG. 5 is a right side elevational view, thereof;

FIG. 6 is a front end elevational view, thereof; and,

FIG. 7 is a rear end elevational view, thereof.

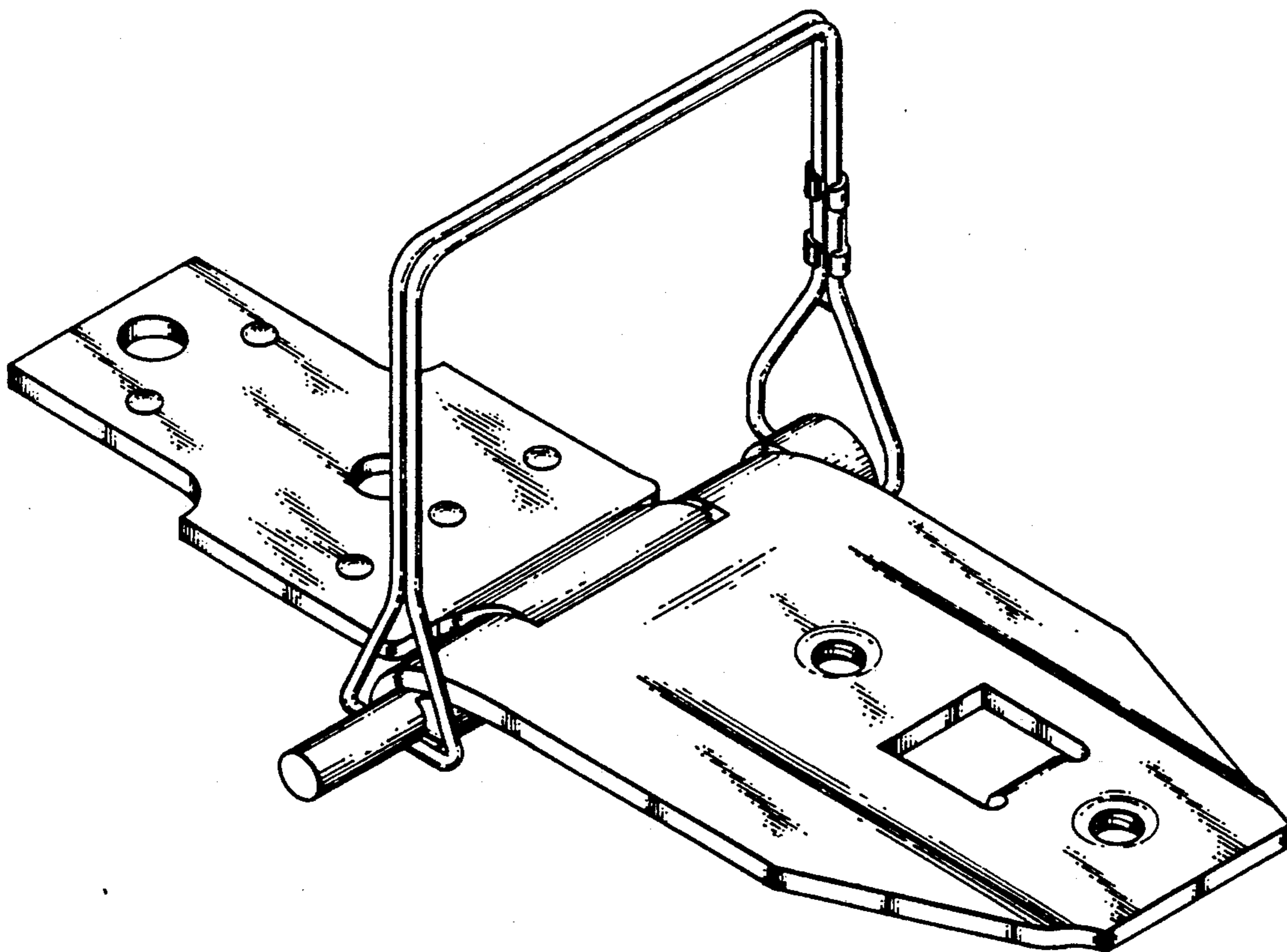

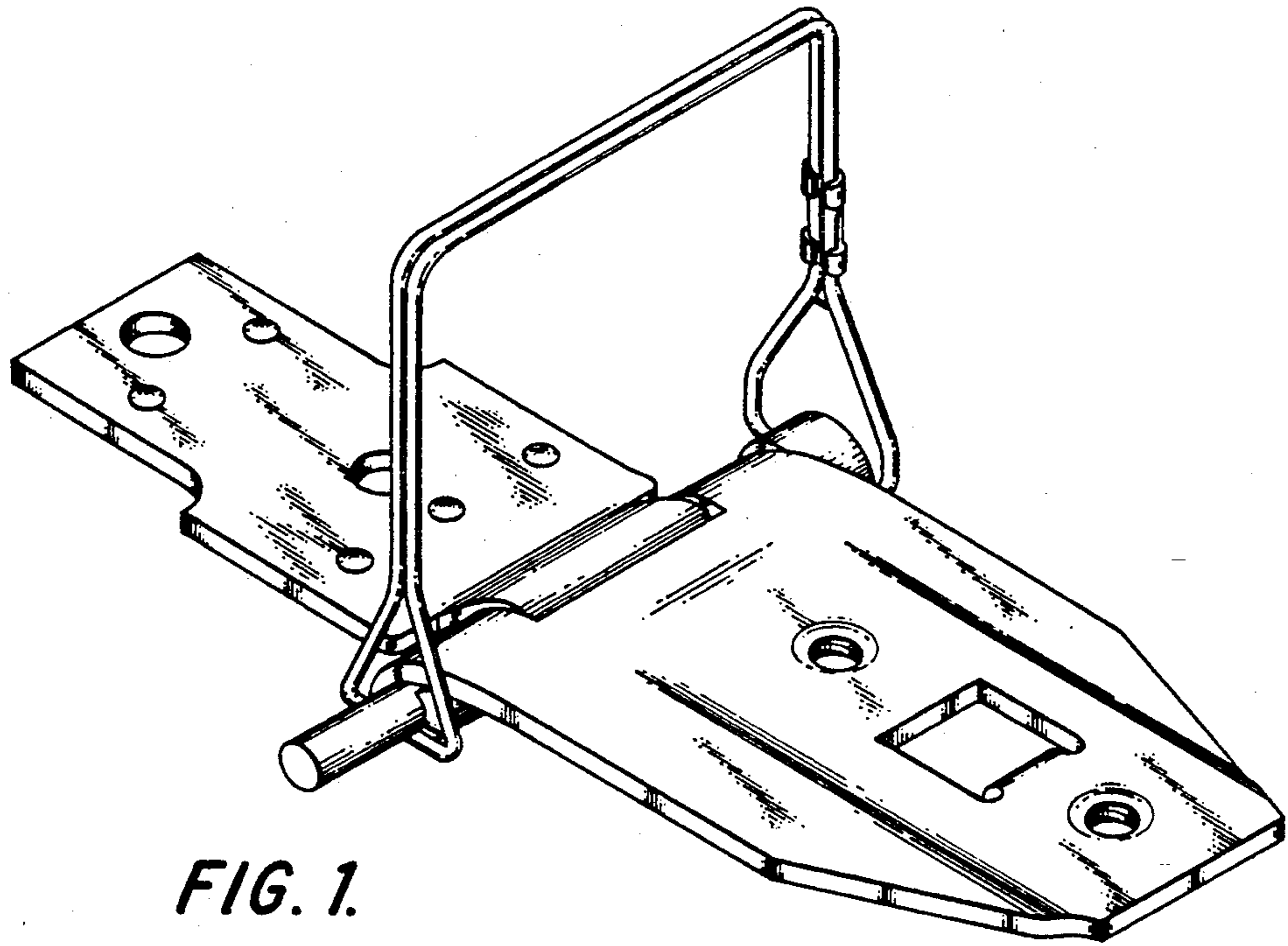

FIG. 1.

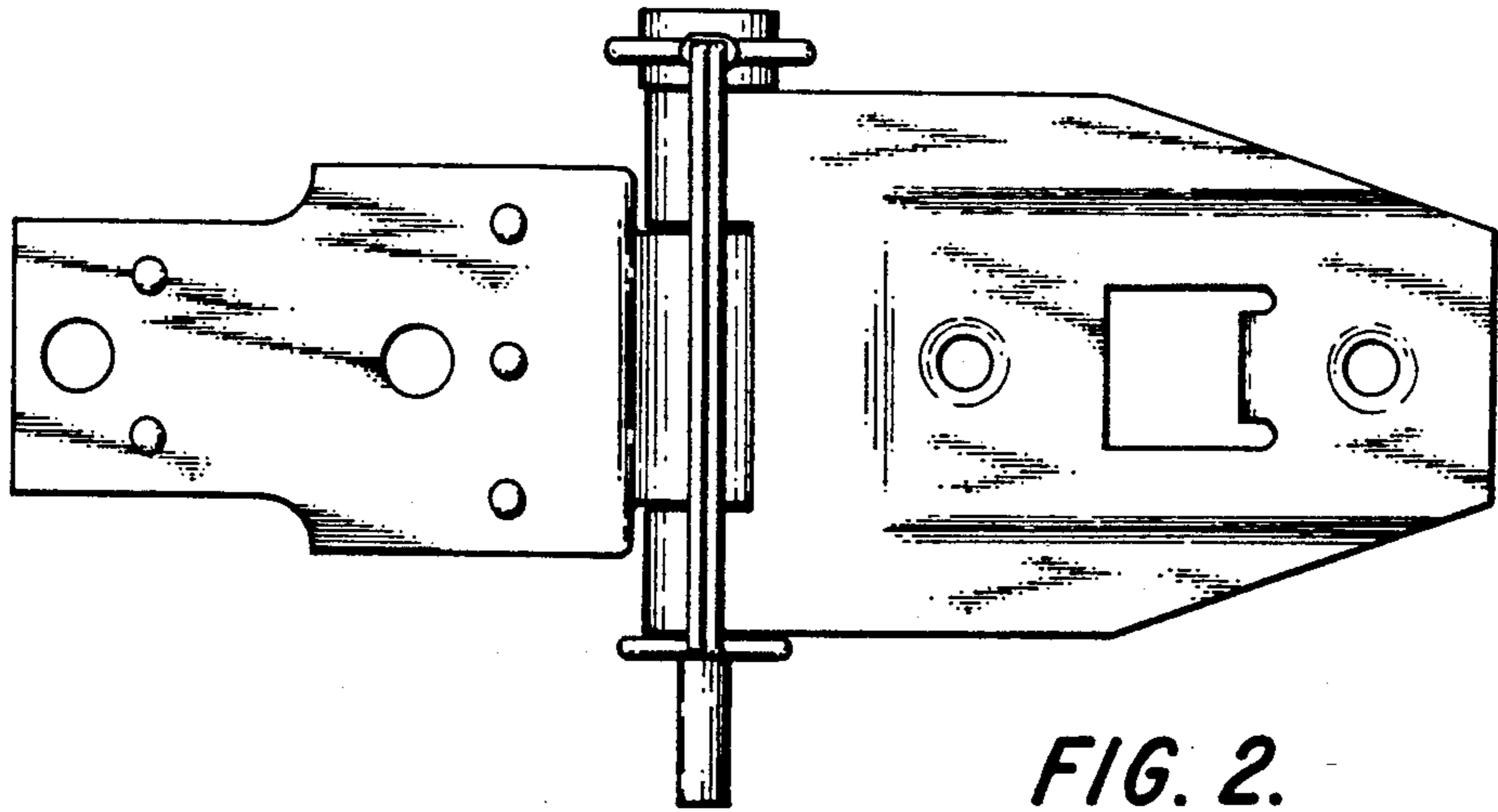

FIG. 2.

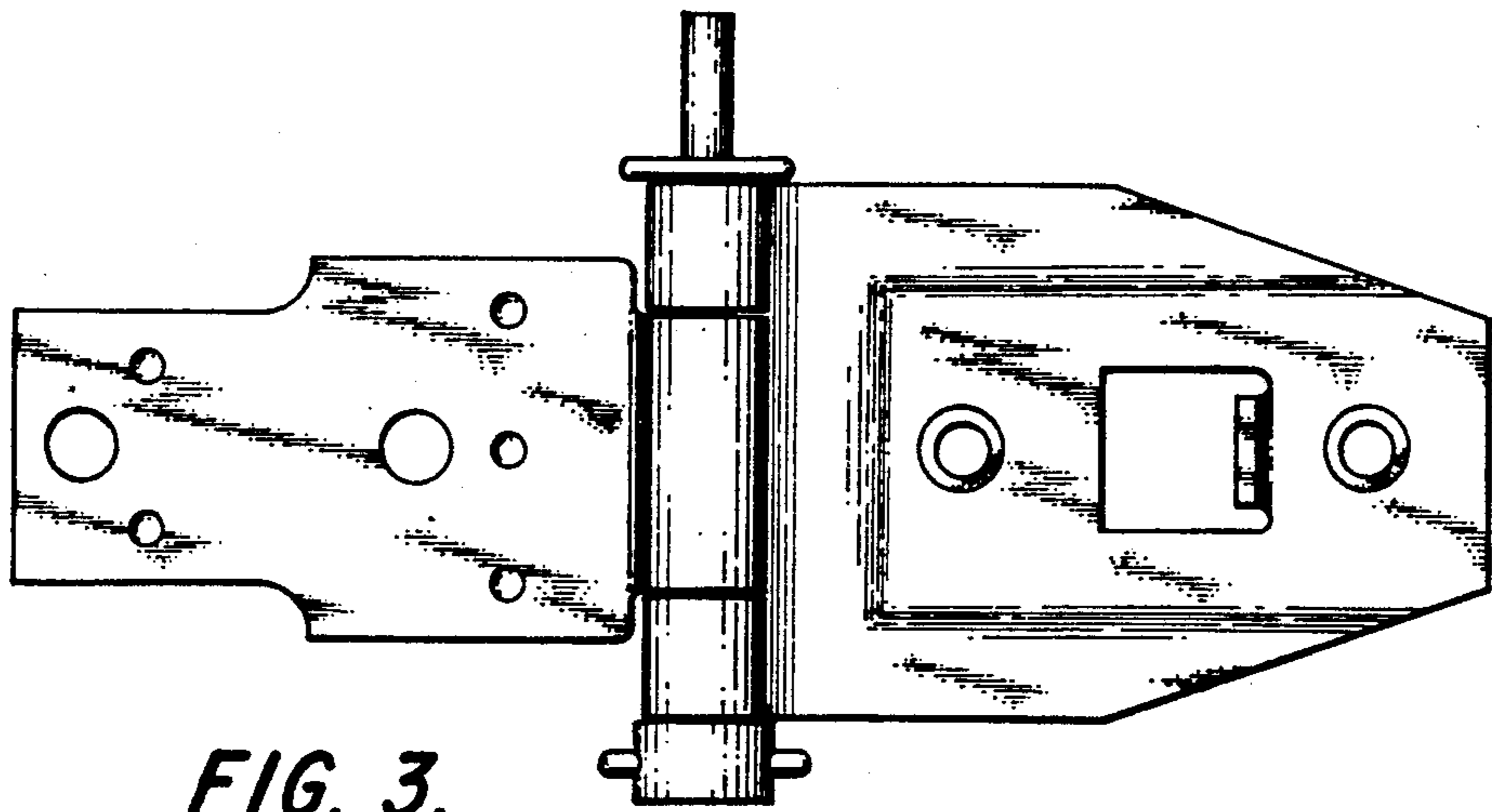

FIG. 3.

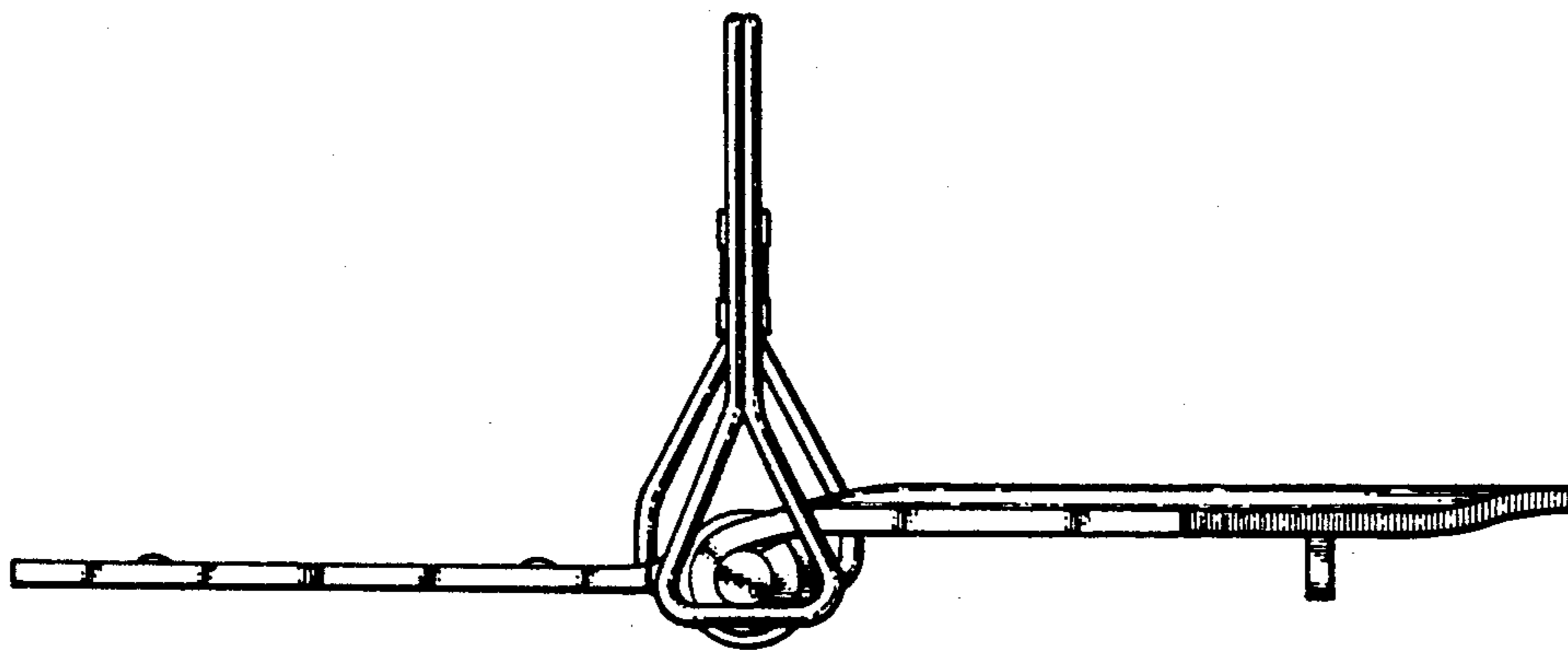

FIG. 4.

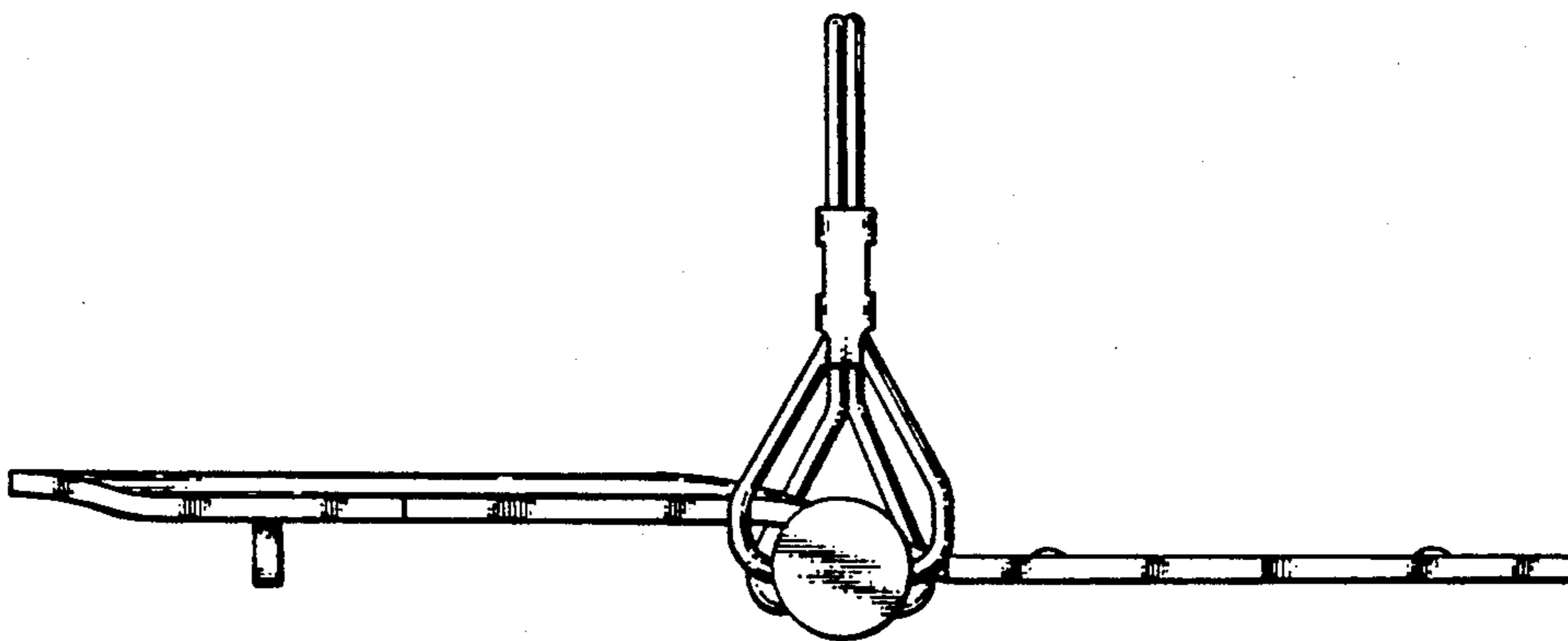

FIG. 5.

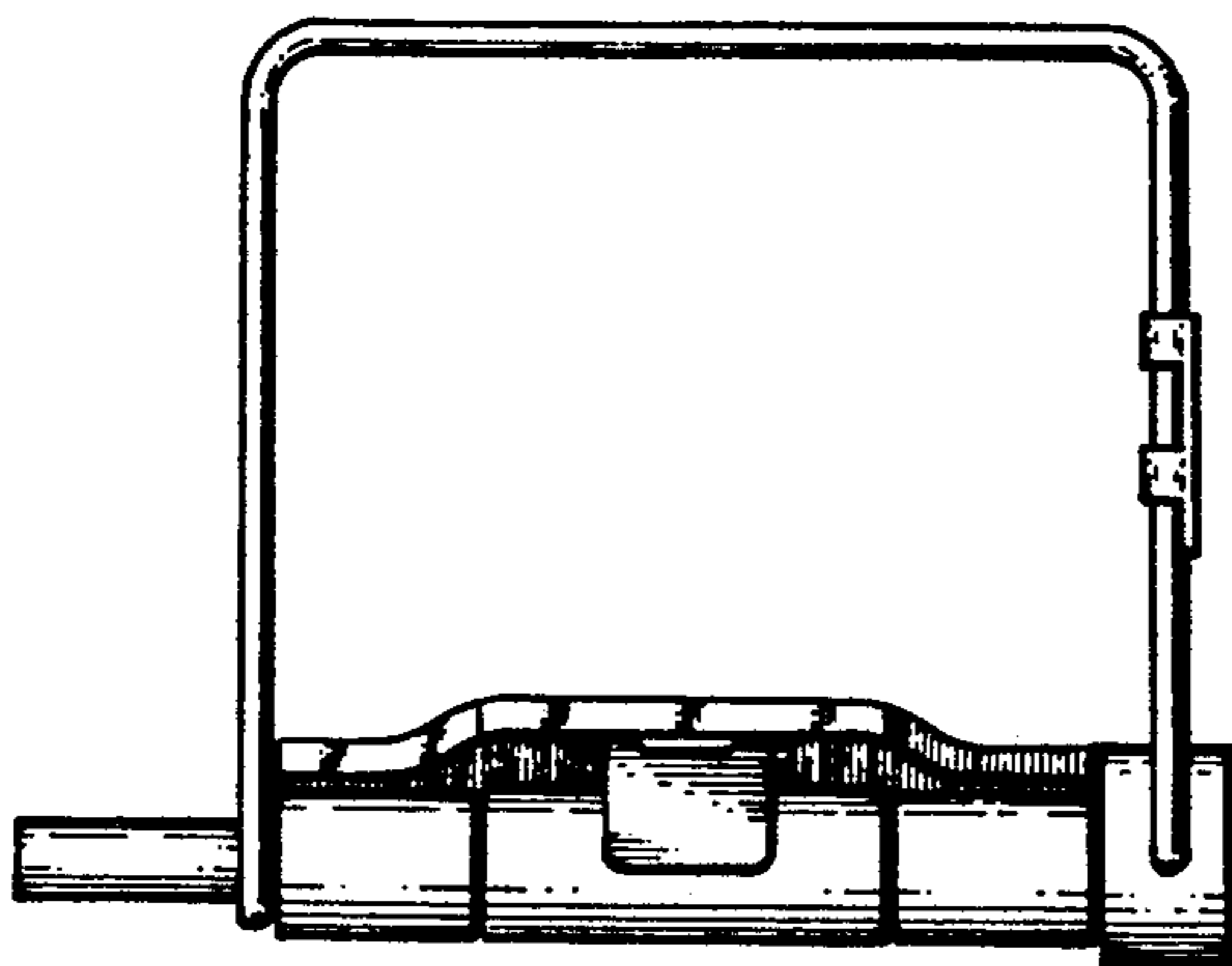

FIG. 6.

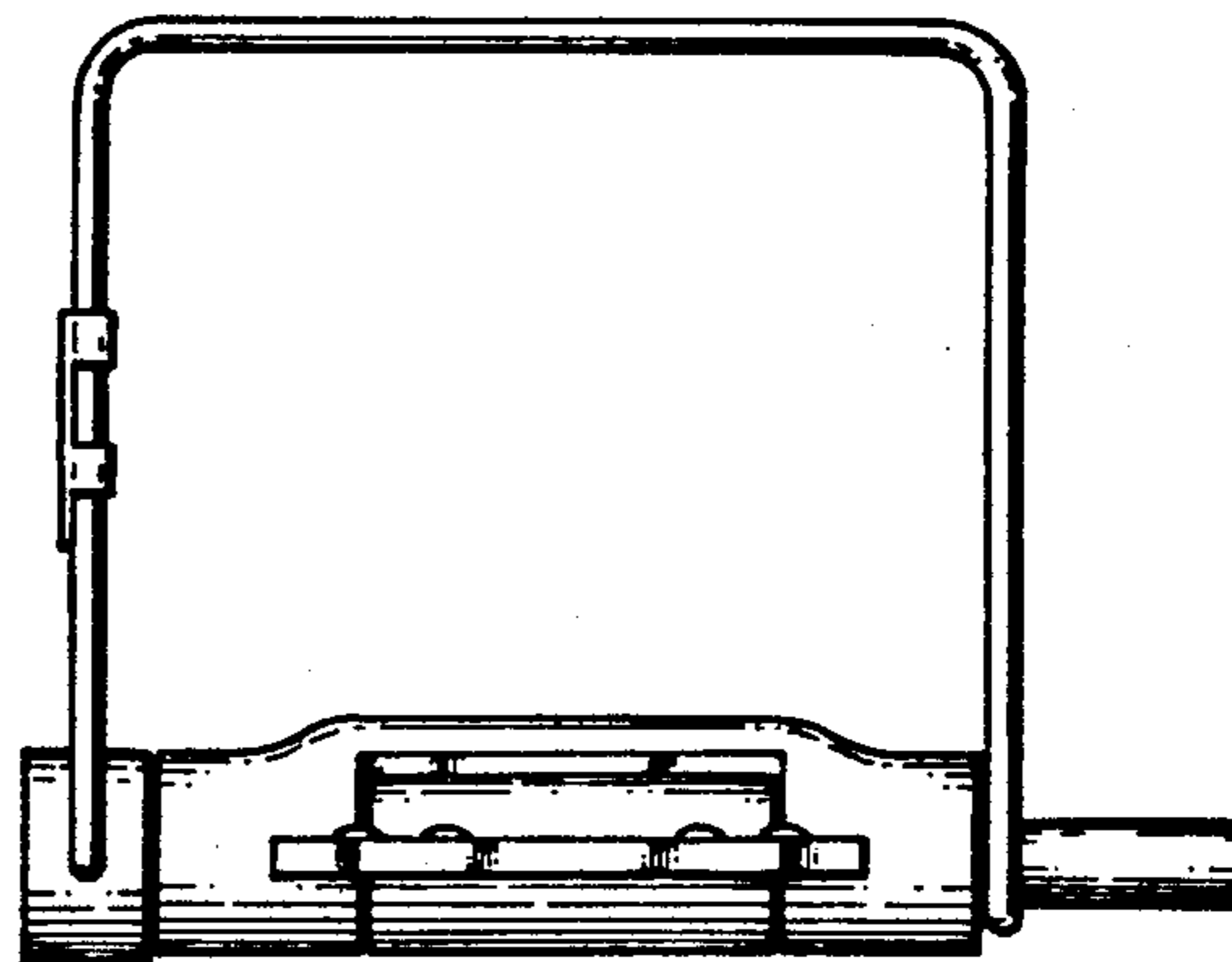

FIG. 7.