



US00D336062S

United States Patent [19]

[11] Patent Number: **Des. 336,062**

Austin

[45] Date of Patent: **** Jun. 1, 1993**

- [54] **PICKUP TRUCK BEDLINER**
- [76] Inventor: **Thomas Austin, 21674 Chipmunk TR, Woodhaven, Mich. 48183**
- [**] Term: **14 Years**
- [21] Appl. No.: **663,652**
- [22] Filed: **Mar. 4, 1991**
- [52] U.S. Cl. **D12/98**
- [58] Field of Search **D12/98; 296/39.1, 39.2, 296/39.3**

5,044,848 9/1991 Burnham 296/39.2

FOREIGN PATENT DOCUMENTS

- 107372 5/1939 Australia .
- 639062 3/1962 Canada .

Primary Examiner—James M. Gandy
Attorney, Agent, or Firm—Terry M. Gernstein

[57] CLAIM

The ornamental design for a pickup truck bedliner, as shown and described.

[56] References Cited

U.S. PATENT DOCUMENTS

3,025,805	3/1962	Ford	105/423
4,750,776	6/1988	Barden	296/39.2
4,872,720	10/1989	Nagy	296/39.1
4,887,947	12/1989	Bott	296/39.2
4,917,431	4/1990	McDonald	296/39.1
4,991,899	2/1991	Scott	296/39.2
5,044,682	9/1991	Wayne	296/39.2

DESCRIPTION

FIG. 1 is a perspective view of the pickup truck bedliner embodying the design of the present invention; FIG. 2 is a front elevational view thereof; FIG. 3 is a rear elevational view thereof; FIG. 4 is a side elevational view thereof, the side opposite being a mirror image of the side shown in FIG. 4; FIG. 5 is a top plan view thereof; and, FIG. 6 is a bottom plan view thereof.

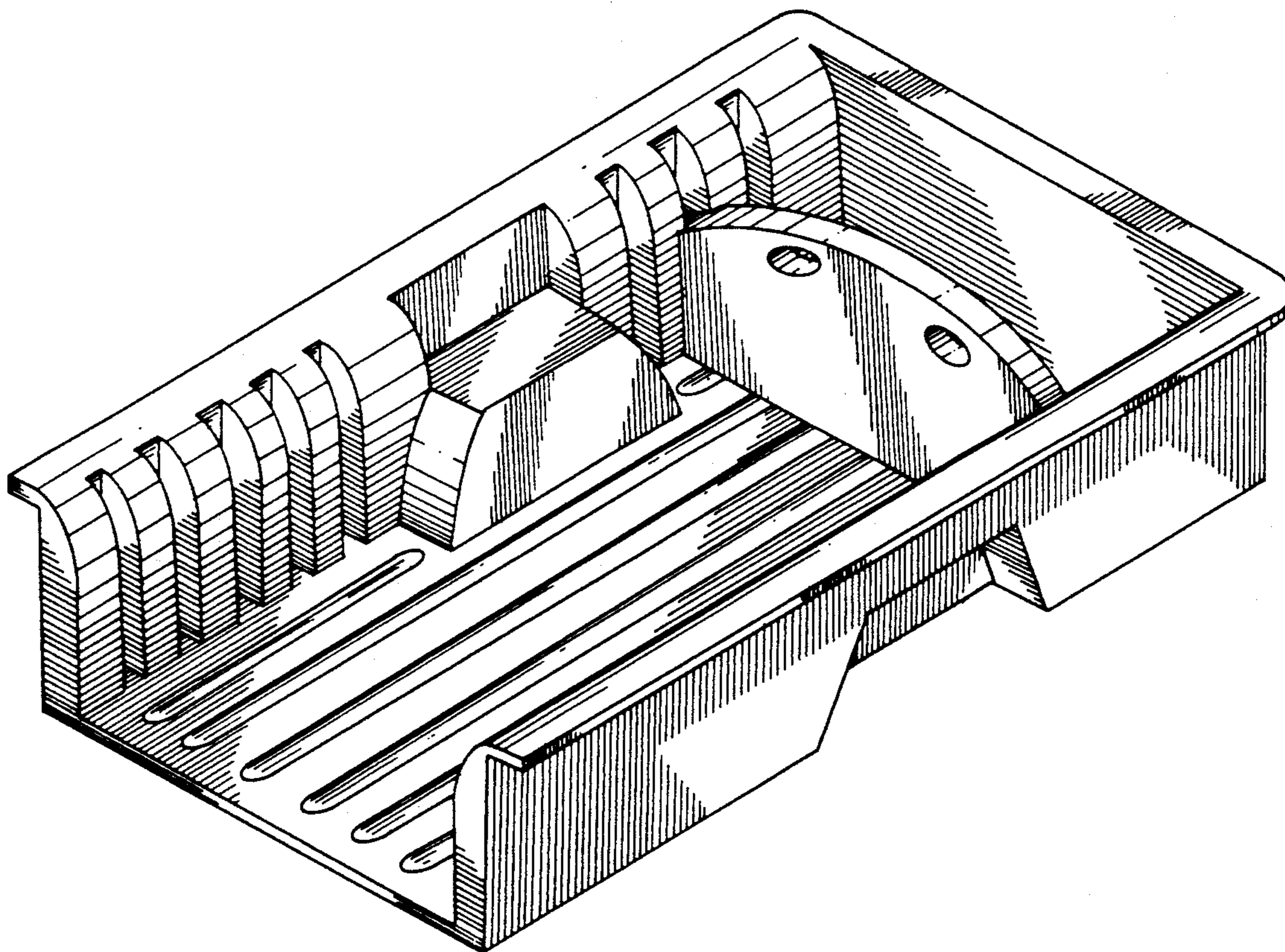
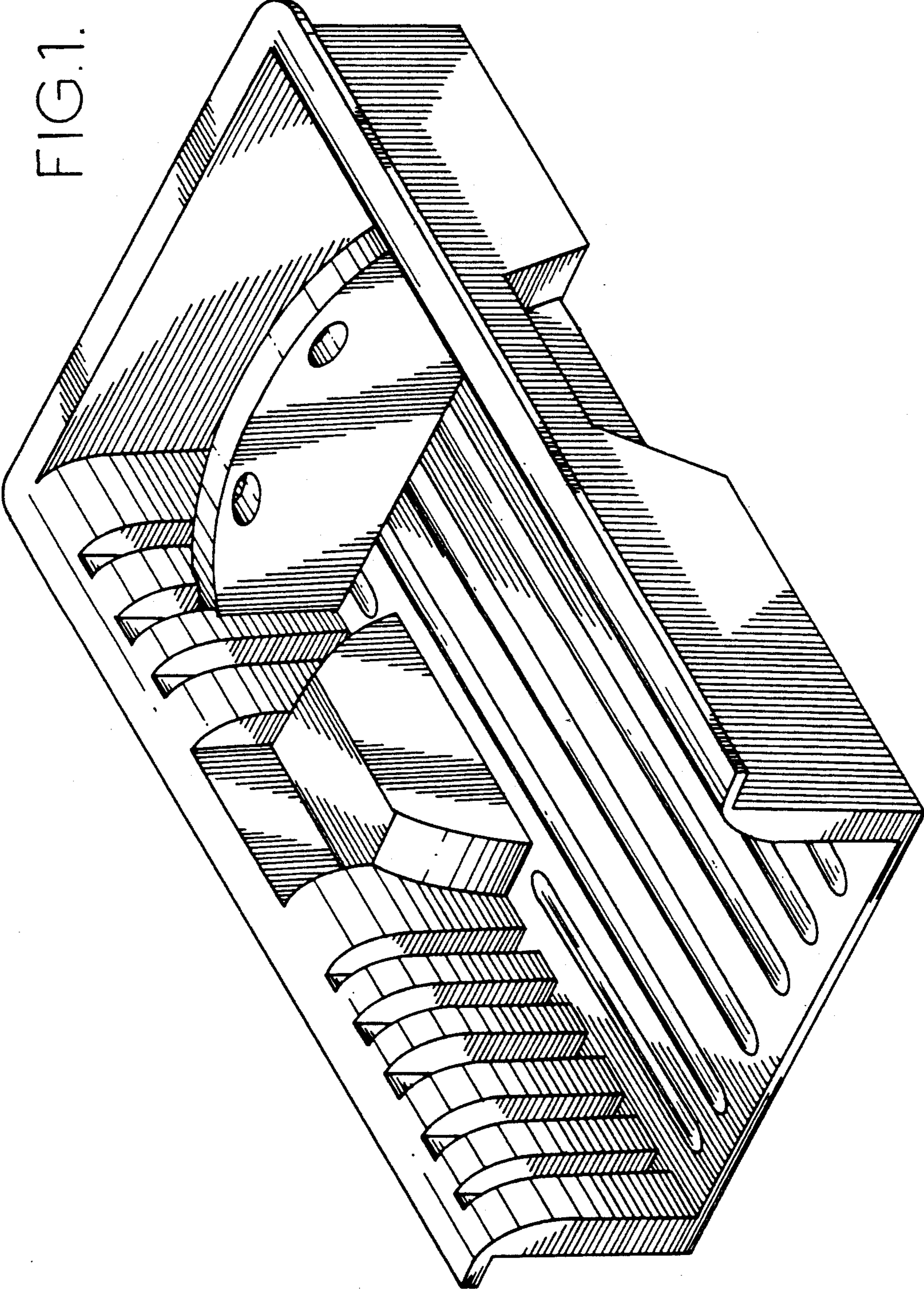

FIG. 1.



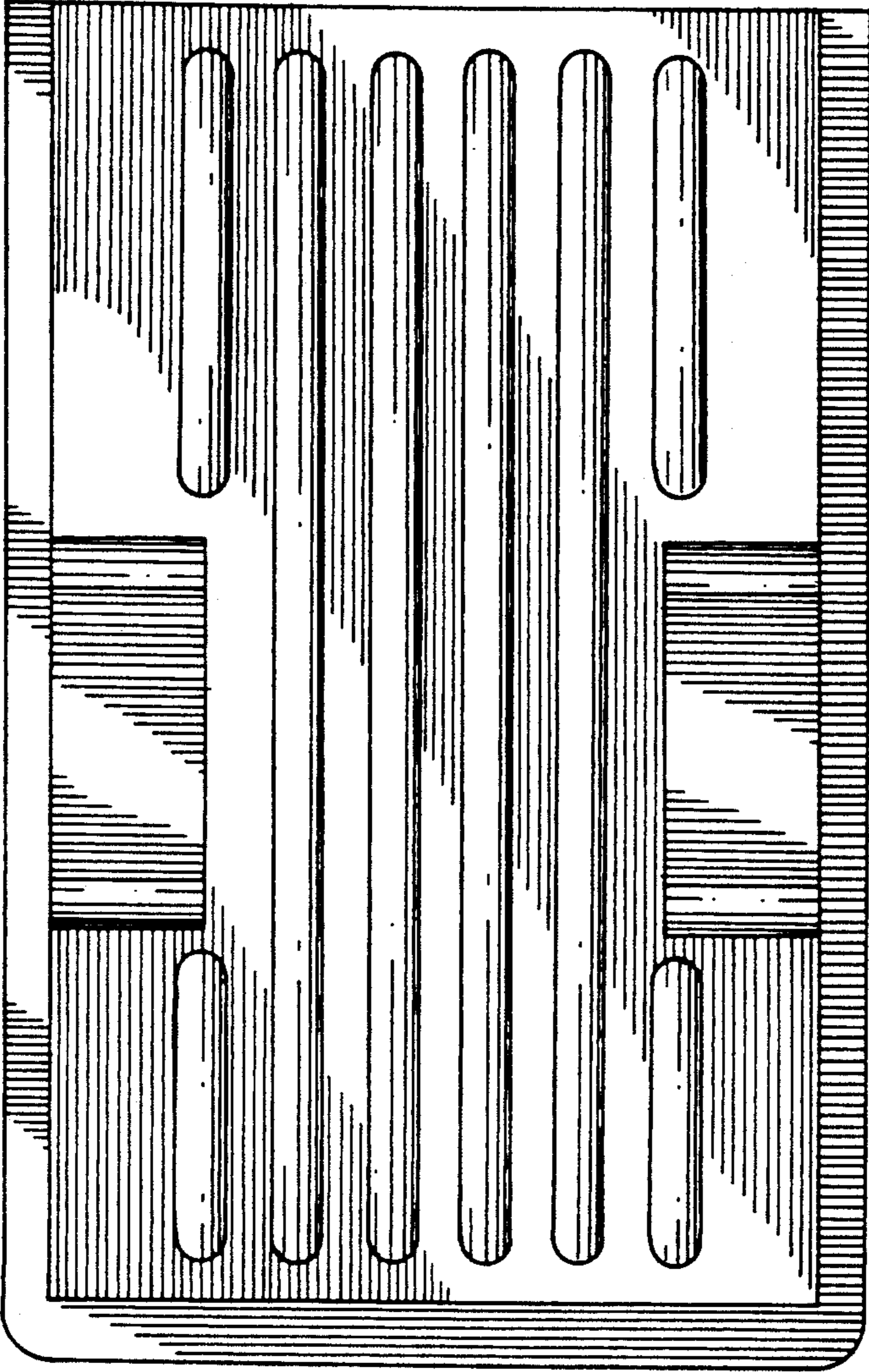

FIG. 6.

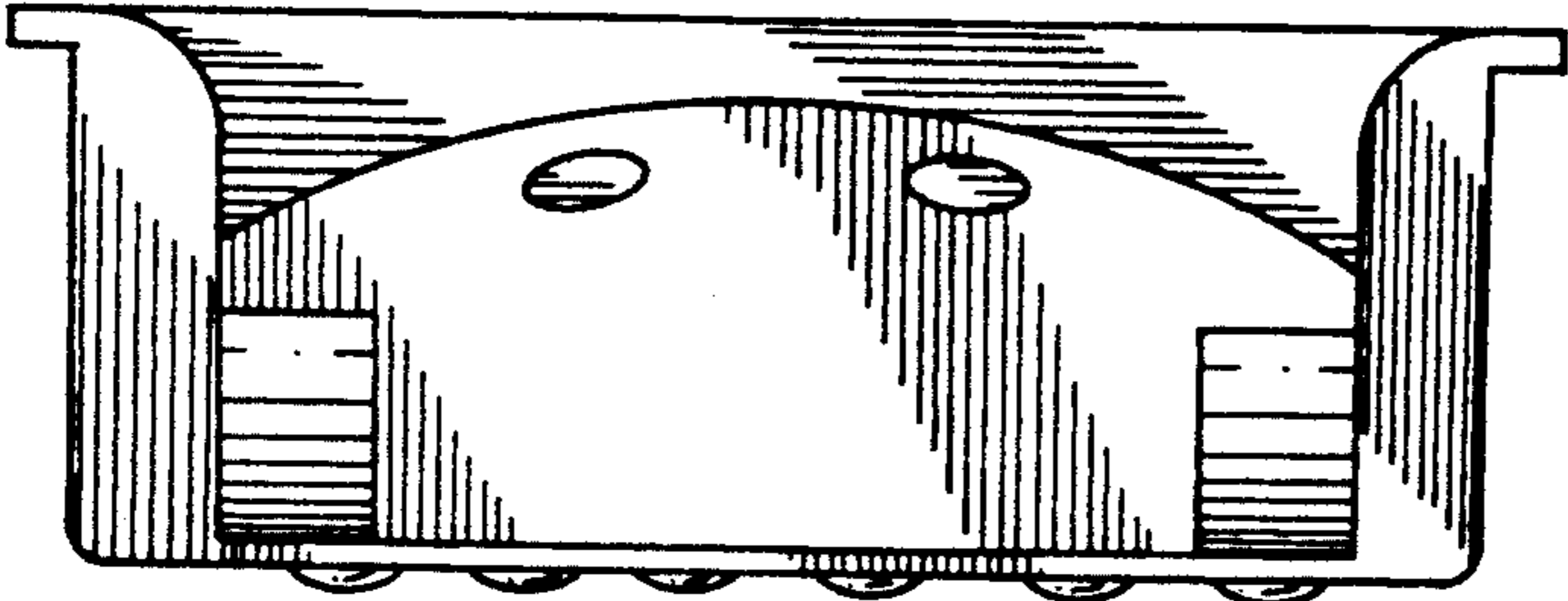

FIG. 2.

FIG. 5.

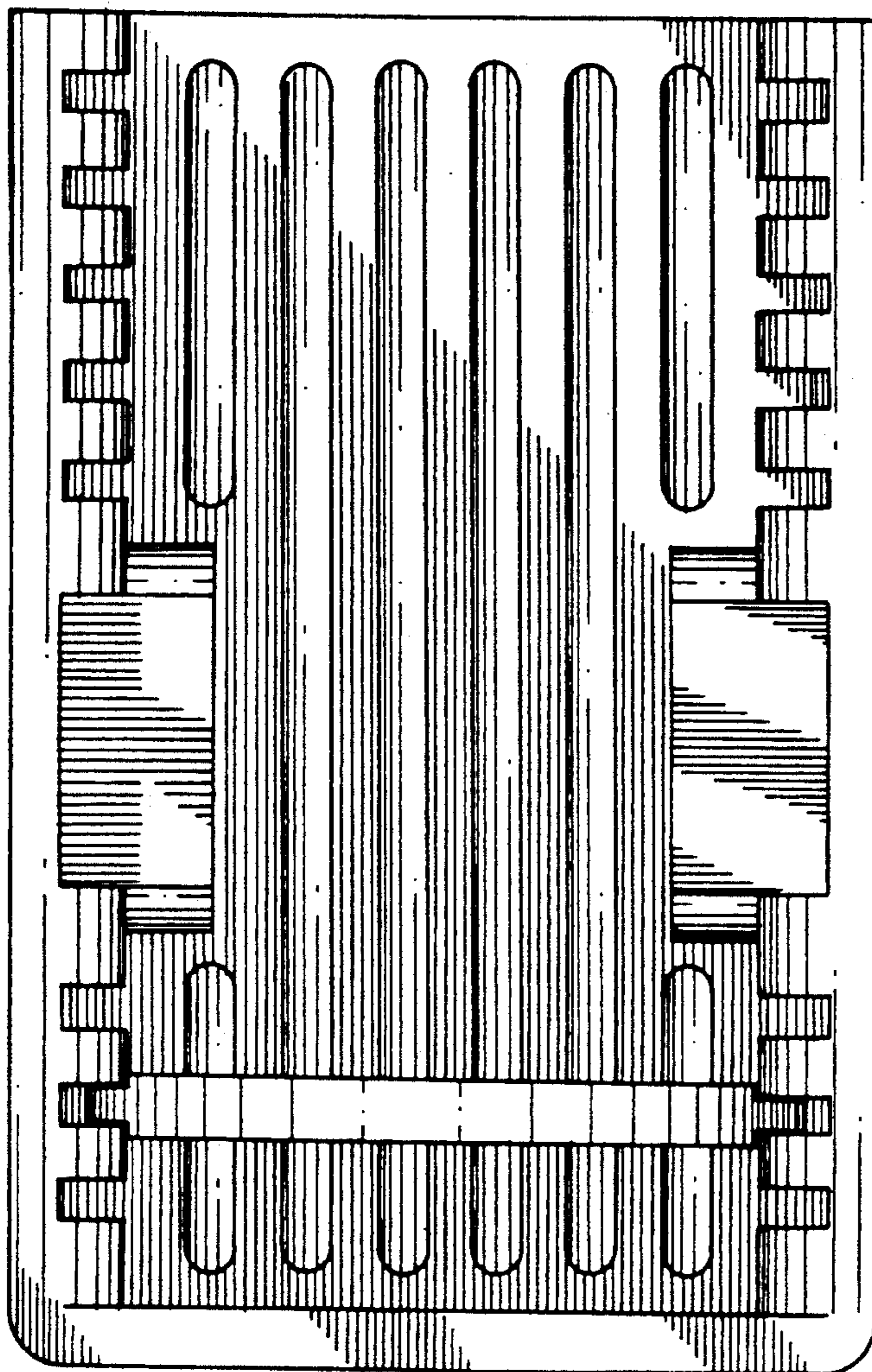

FIG. 4.

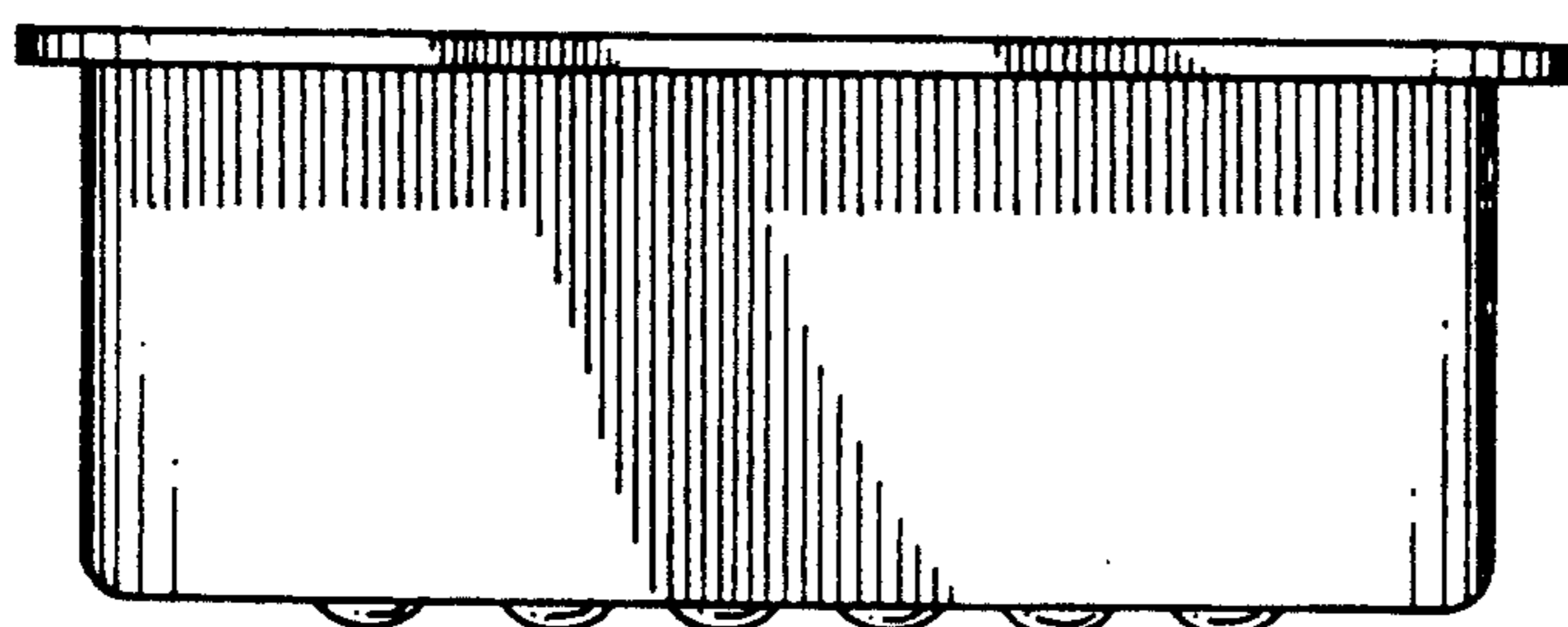
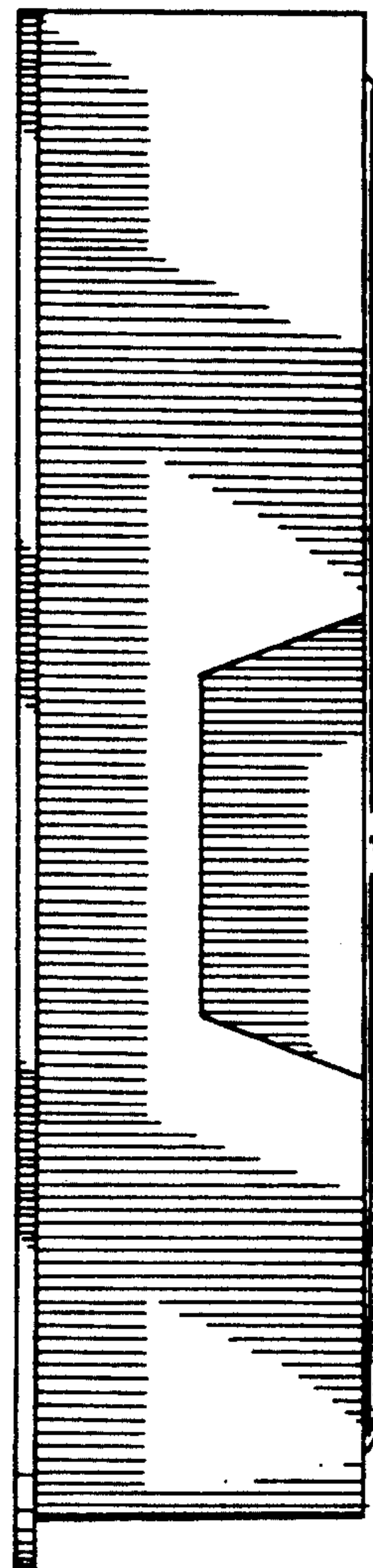

FIG. 3.