



US00D336011S

United States Patent [19]
Bannigan

[11] **Patent Number: Des. 336,011**
[45] **Date of Patent: ** Jun. 1, 1993**

[54] **FILTER CARTRIDGE**

[56] **References Cited**

[75] **Inventor: Francis R. Bannigan, Victoria, Australia**

[73] **Assignee: Kambrook Distributing Pty. Ltd., Australia**

[**] **Term: 14 Years**

[21] **Appl. No.: 714,765**

[22] **Filed: Jun. 12, 1991**

[30] **Foreign Application Priority Data**

Jan. 14, 1991 [AU] Australia 102/91
Mar. 6, 1991 [AU] Australia 647/91
[52] **U.S. Cl.** **D7/400; D23/209**
[58] **Field of Search** **D7/305, 306, 307, 400, D7/309, 399, 310, 509, 510, 511; D23/209; D32/53; 210/500.23, 500.1, 477, 482, 481; 99/295, 306, 323**

U.S. PATENT DOCUMENTS

D. 290,323	6/1987	Weernink	D7/511
513,215	1/1894	Strater	210/477
1,078,171	11/1913	Shaw	210/477
4,508,235	4/1985	Steele et al.	D7/510 X
4,666,600	5/1987	Hankammer	210/477 X
4,764,274	8/1988	Miller	210/482 X
4,783,318	11/1988	Lapakko	210/482 X
4,990,254	2/1991	Toida et al.	210/477 X

Primary Examiner—Alan P. Douglas
Assistant Examiner—M. N. Pandozzi
Attorney, Agent, or Firm—Andrus, Sceales, Starke & Sawall

[57] **CLAIM**

The ornamental design for a filter cartridge, as shown.

DESCRIPTION

FIG. 1 is a perspective view from one end of a filter cartridge incorporating my new design;
FIG. 2 is a perspective view from the other end of the filter cartridge;
FIG. 3 is a side view of the filter cartridge;
FIG. 4 is a top plan view of the filter cartridge; and,
FIG. 5 is a bottom plan view of the filter cartridge.

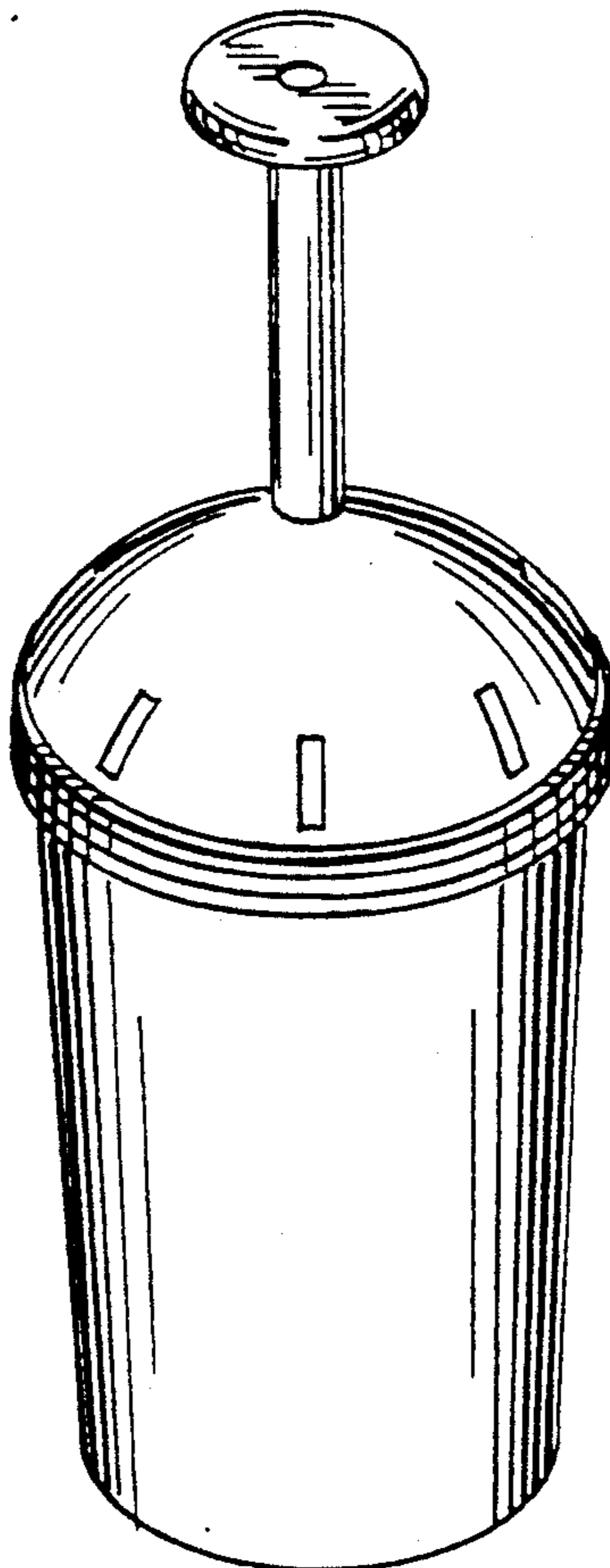

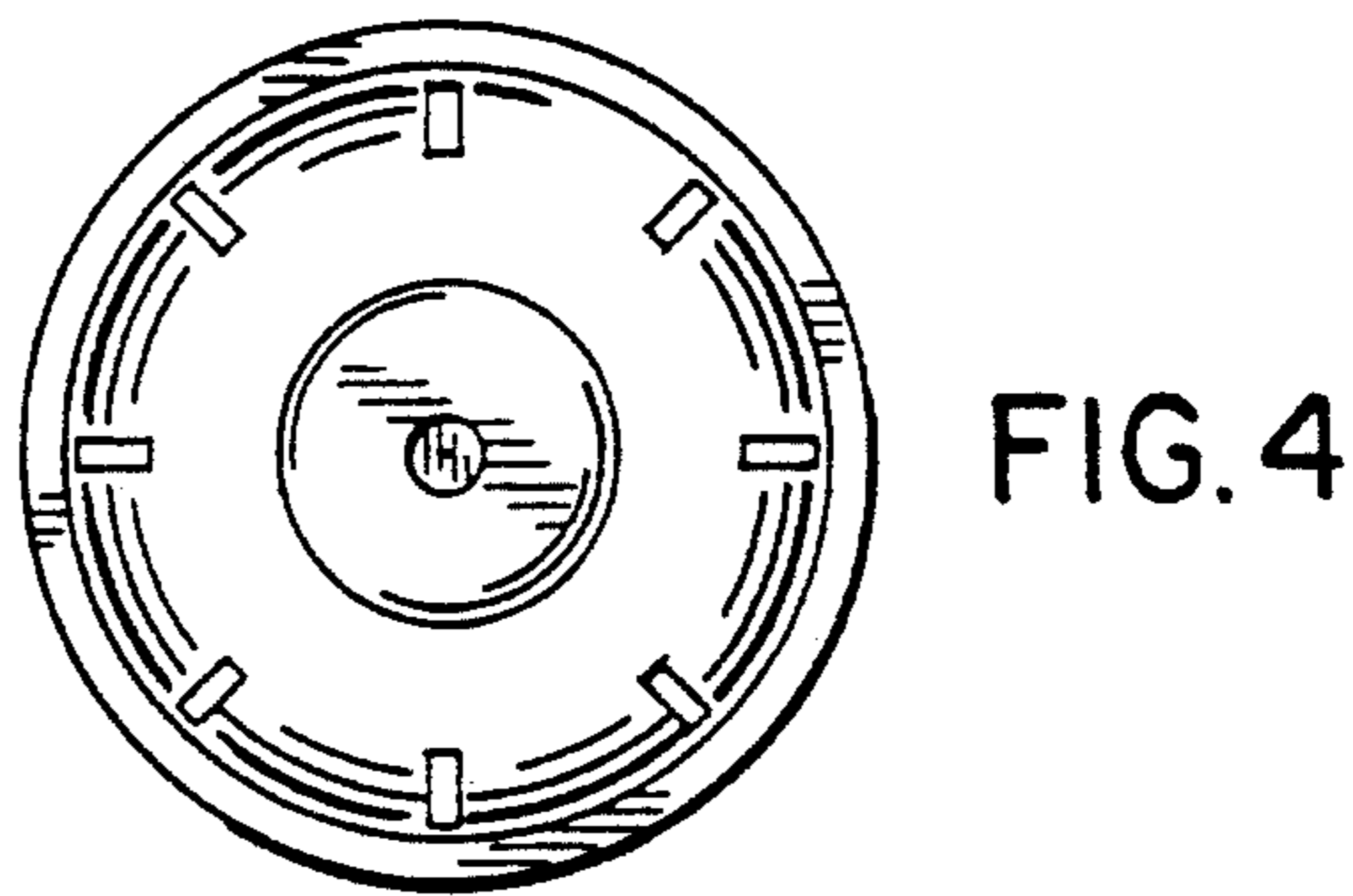
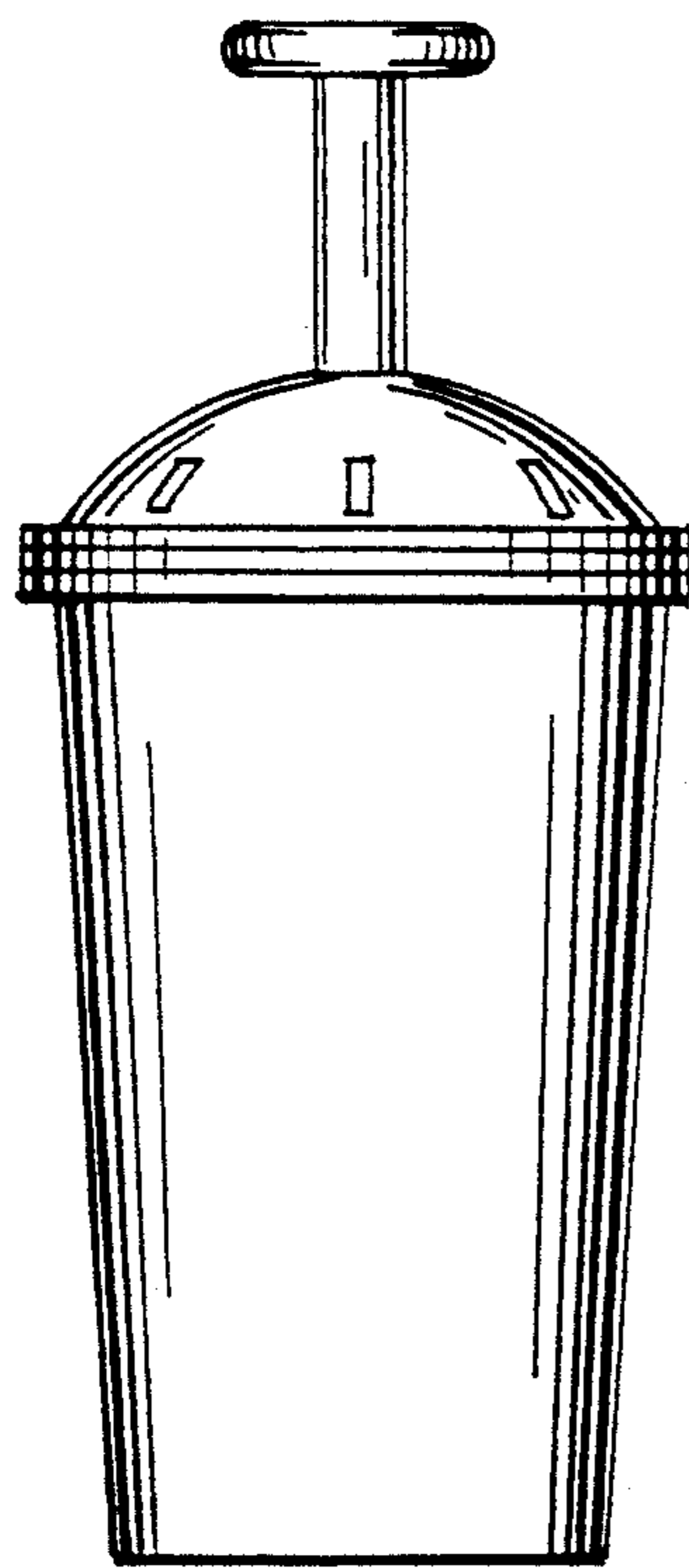
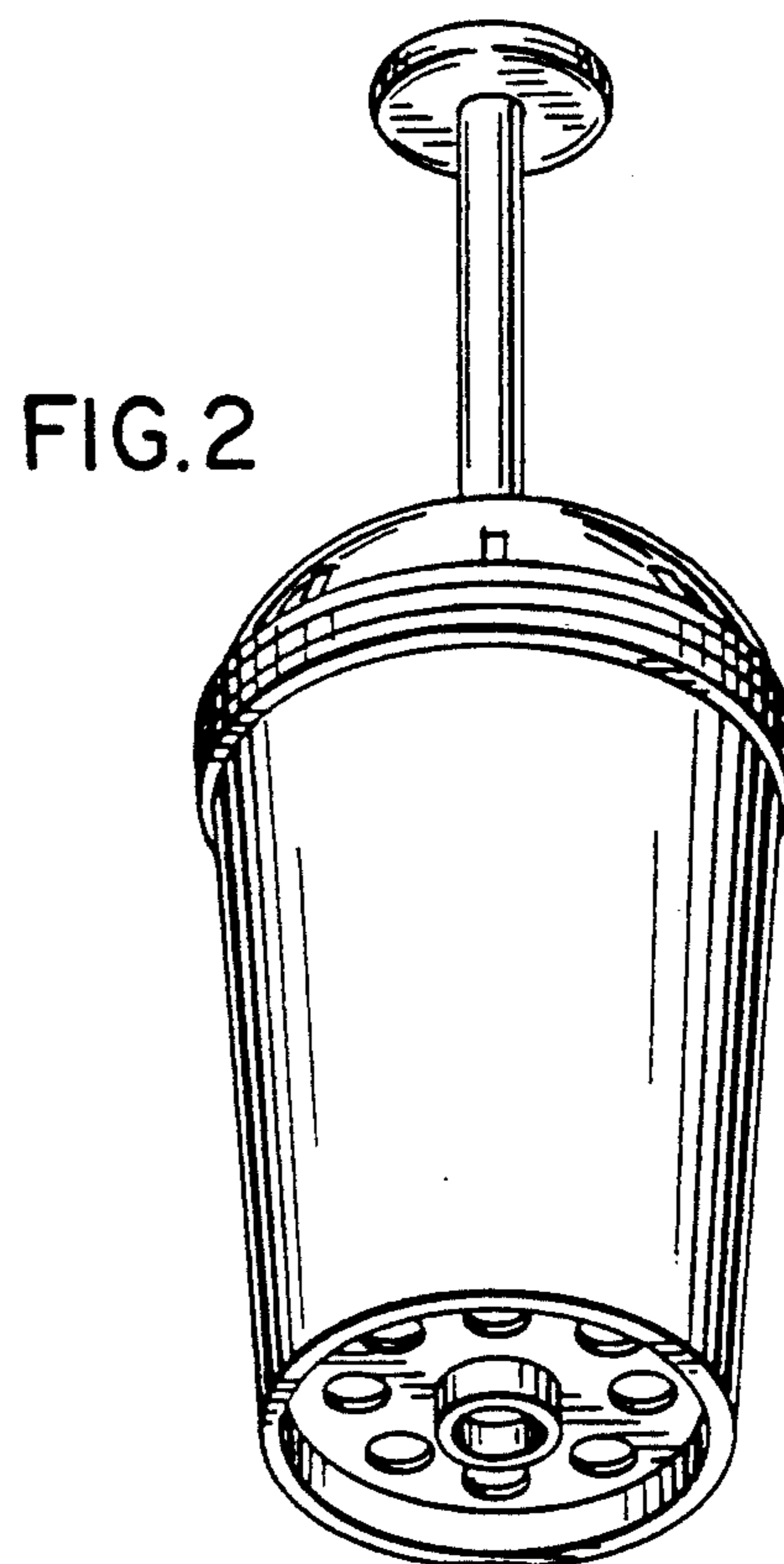
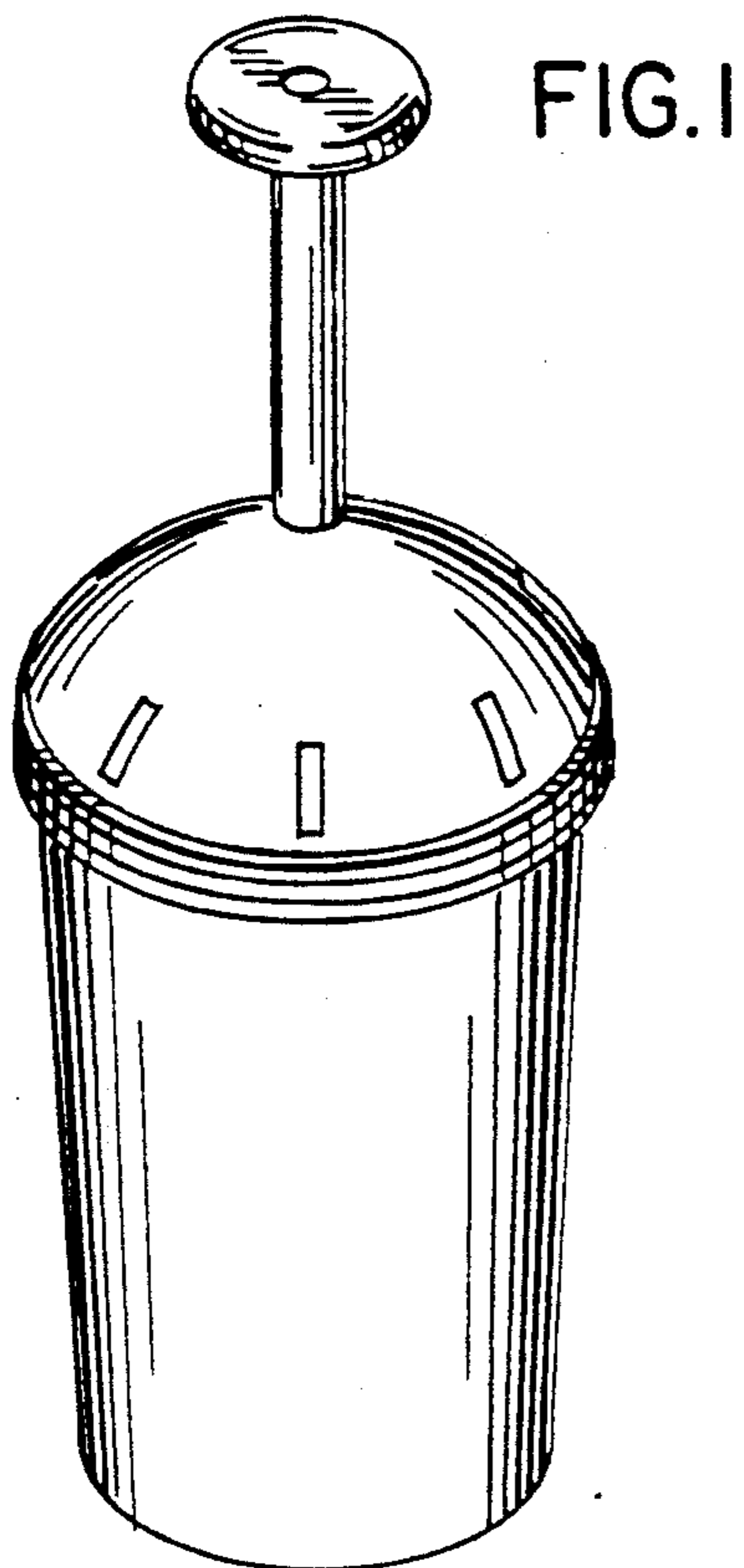

FIG. 3

FIG. 5

