



US00D335968S

United States Patent [19]

[11] Patent Number: **Des. 335,968**

Bengtson et al.

[45] Date of Patent: **** Jun. 1, 1993**

[54] SEAT

[75] Inventors: **Alan D. Bengtson**, Sheboygan; **David J. O'Connell**, Sturgeon Bay, both of Wis.

[73] Assignee: **Kohler Co.**, Kohler, Wis.

[**] Term: **14 Years**

[21] Appl. No.: **639,952**

[22] Filed: **Jan. 11, 1991**

[52] U.S. Cl. **D6/370; D6/368; D23/304**

[58] Field of Search **D6/334, 368, 370, 374, D6/375, 380, 500, 501, 502; D12/128, 131; D23/303-304; 4/531, 532, 578.1, 579, 590, 611; 297/352, 377**

[56] **References Cited**

U.S. PATENT DOCUMENTS

2,322,147 6/1943 Landauer 297/377

OTHER PUBLICATIONS

P. 13 from Kohler catalog showing the "Freewill" seat, undated, admitted prior art.

Two pages from a Fiat catalog showing MSH shower seats, undated, admitted prior art.

P. 14 from a Kohler catalog showing the Tobago enclosure, undated, admitted prior art.

Primary Examiner—Alan P. Douglas
Assistant Examiner—Gary D. Watson
Attorney, Agent, or Firm—Quarles & Brady

[57] CLAIM

The ornamental design for a seat, as shown and described.

DESCRIPTION

FIG. 1 is a perspective view taken from the top and front of a seat showing our new design;

FIG. 2 is a front elevational view thereof;

FIG. 3 is a top plan view thereof;

FIG. 4 is a right side elevational view thereof, the left side being the mirror image of the right side shown; and,

FIG. 5 is a cross-sectional view taken on line 5—5 of FIG. 2.

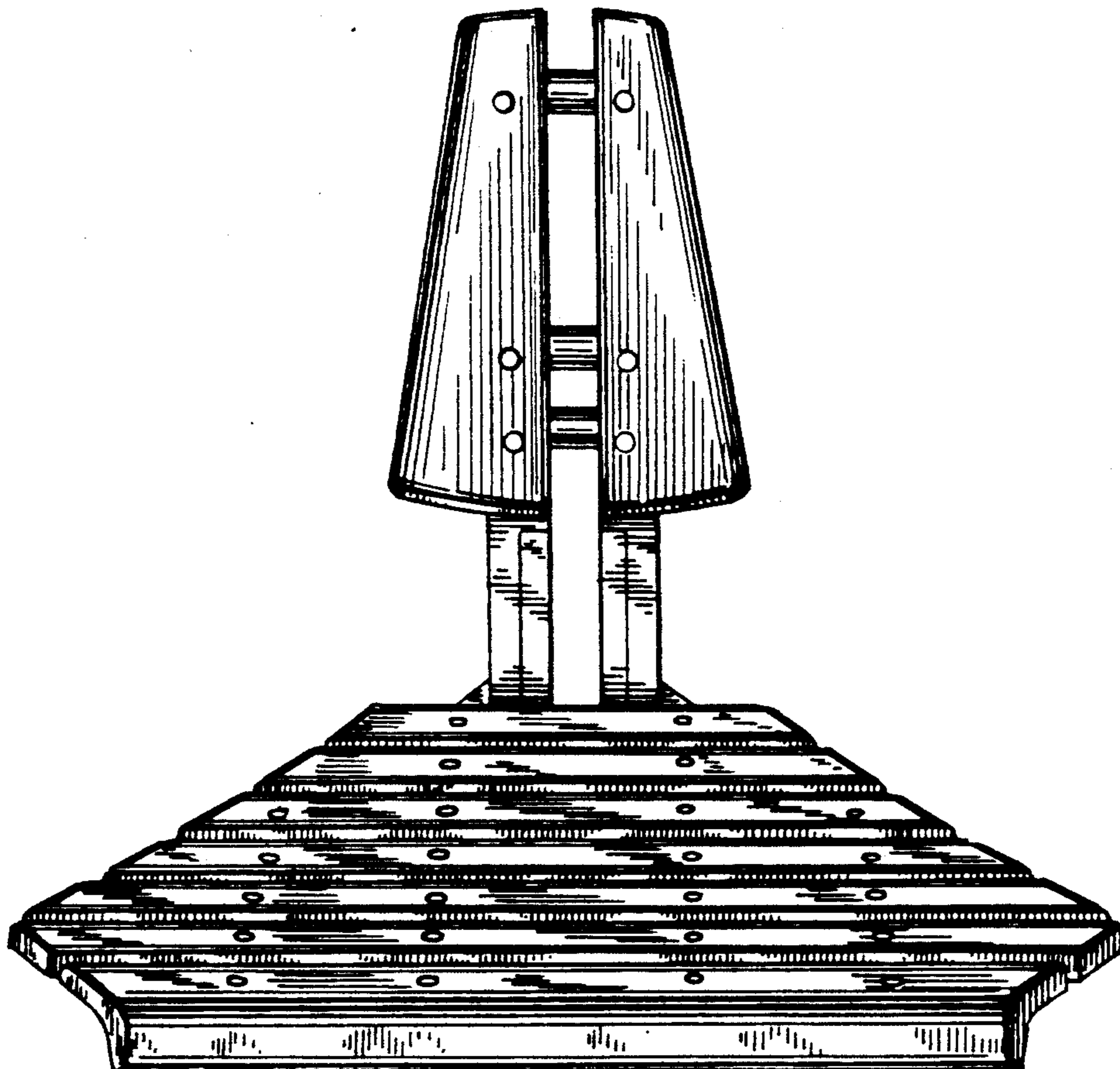

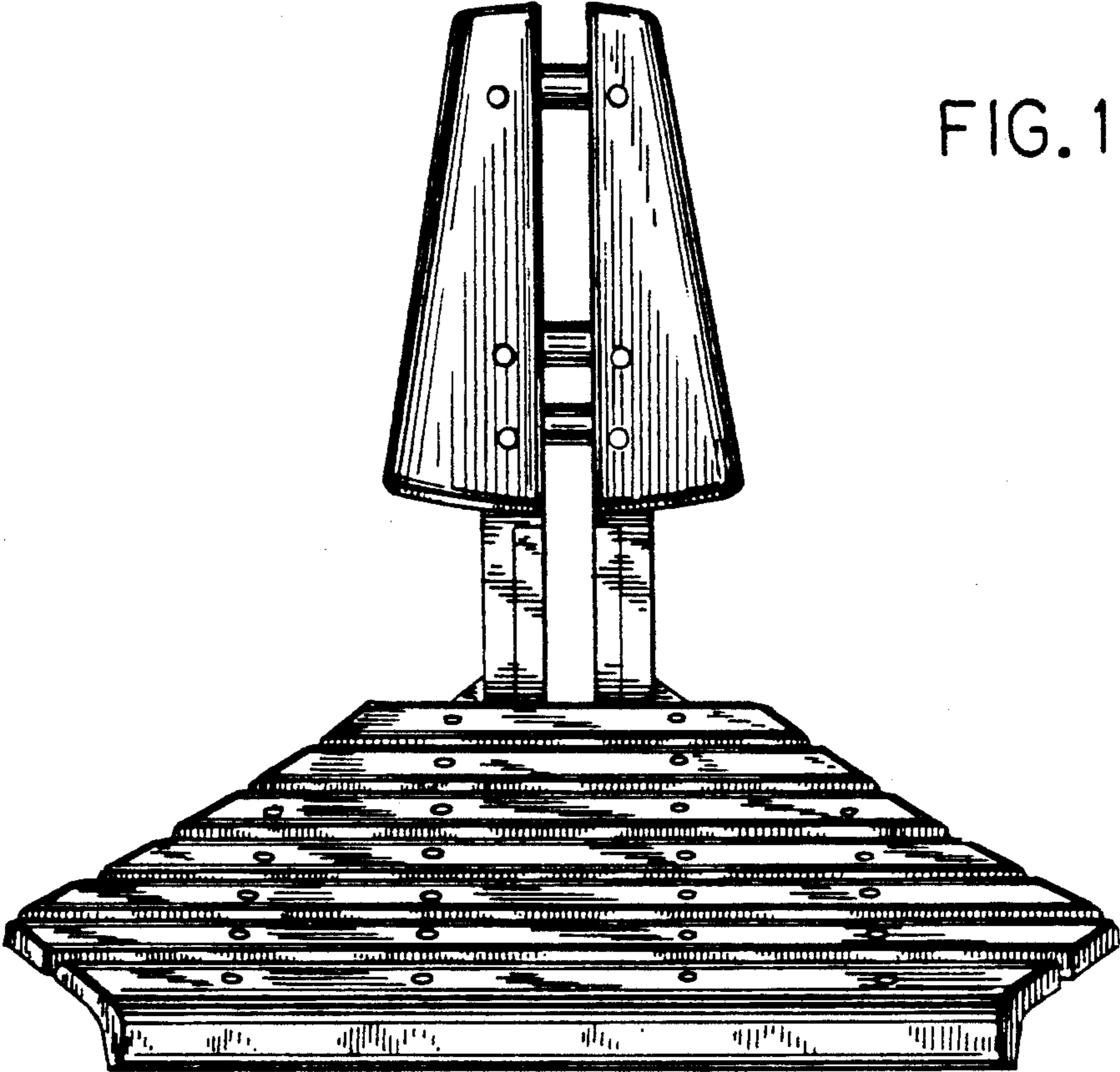

FIG. 1

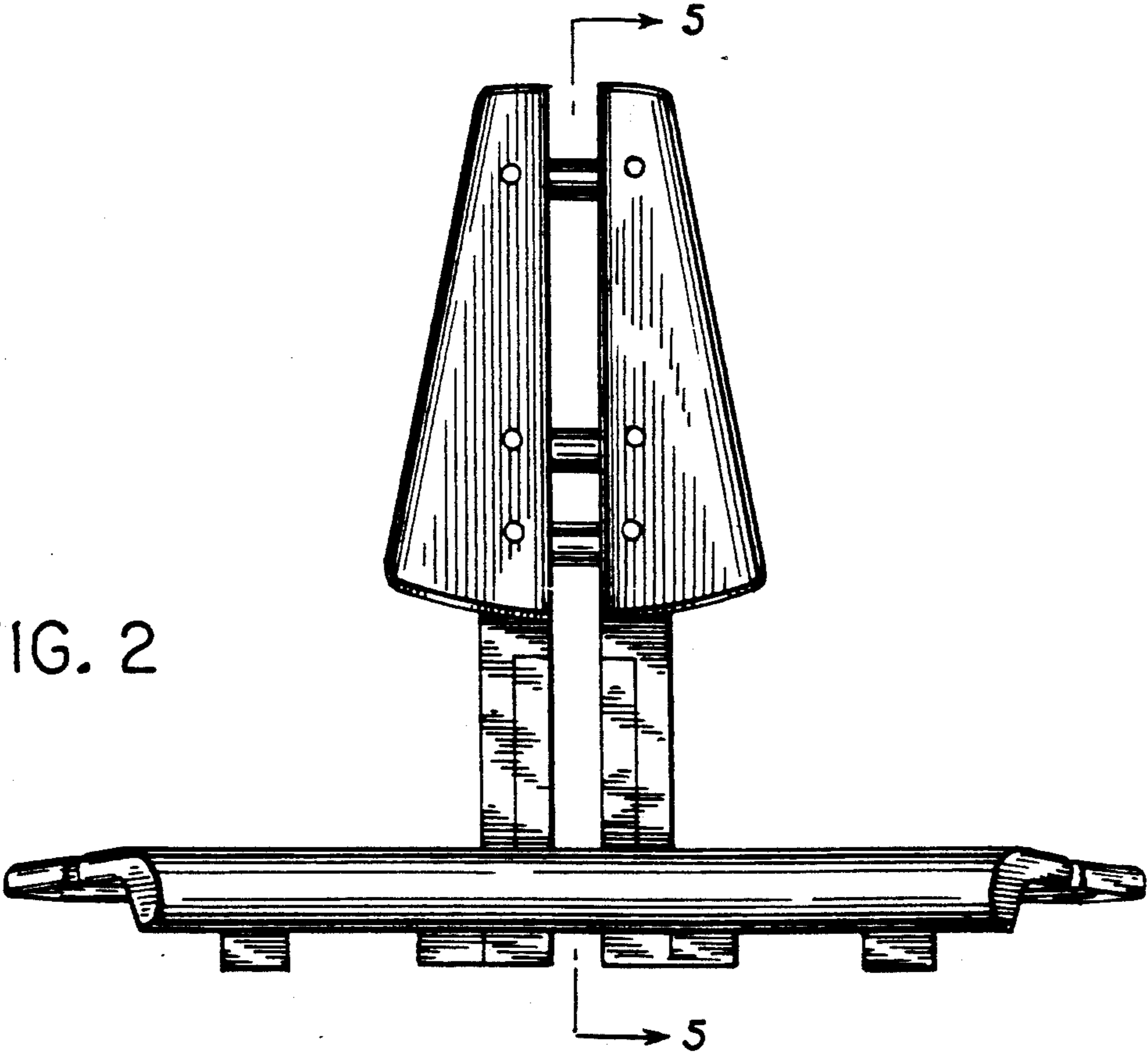

FIG. 2

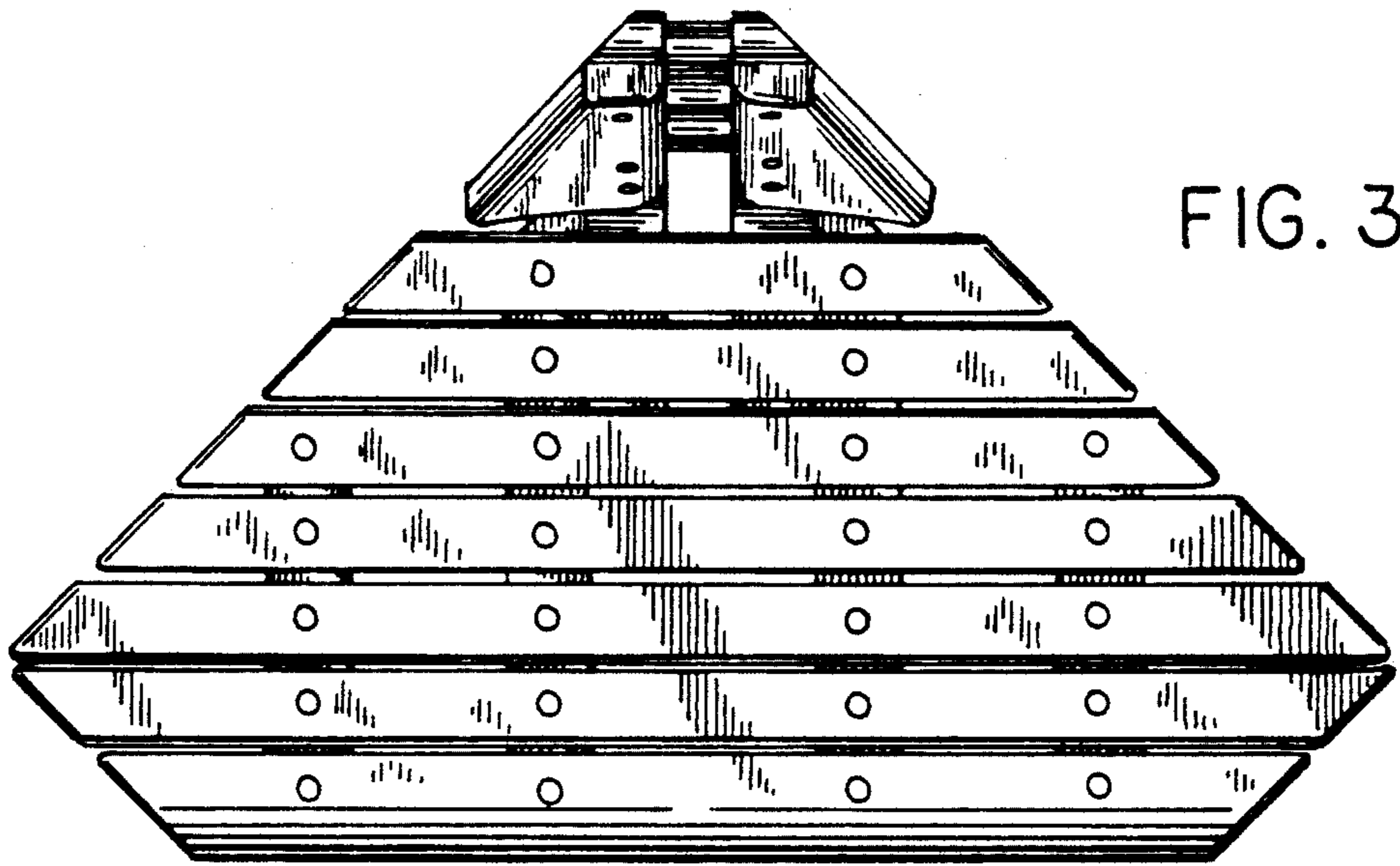

FIG. 3

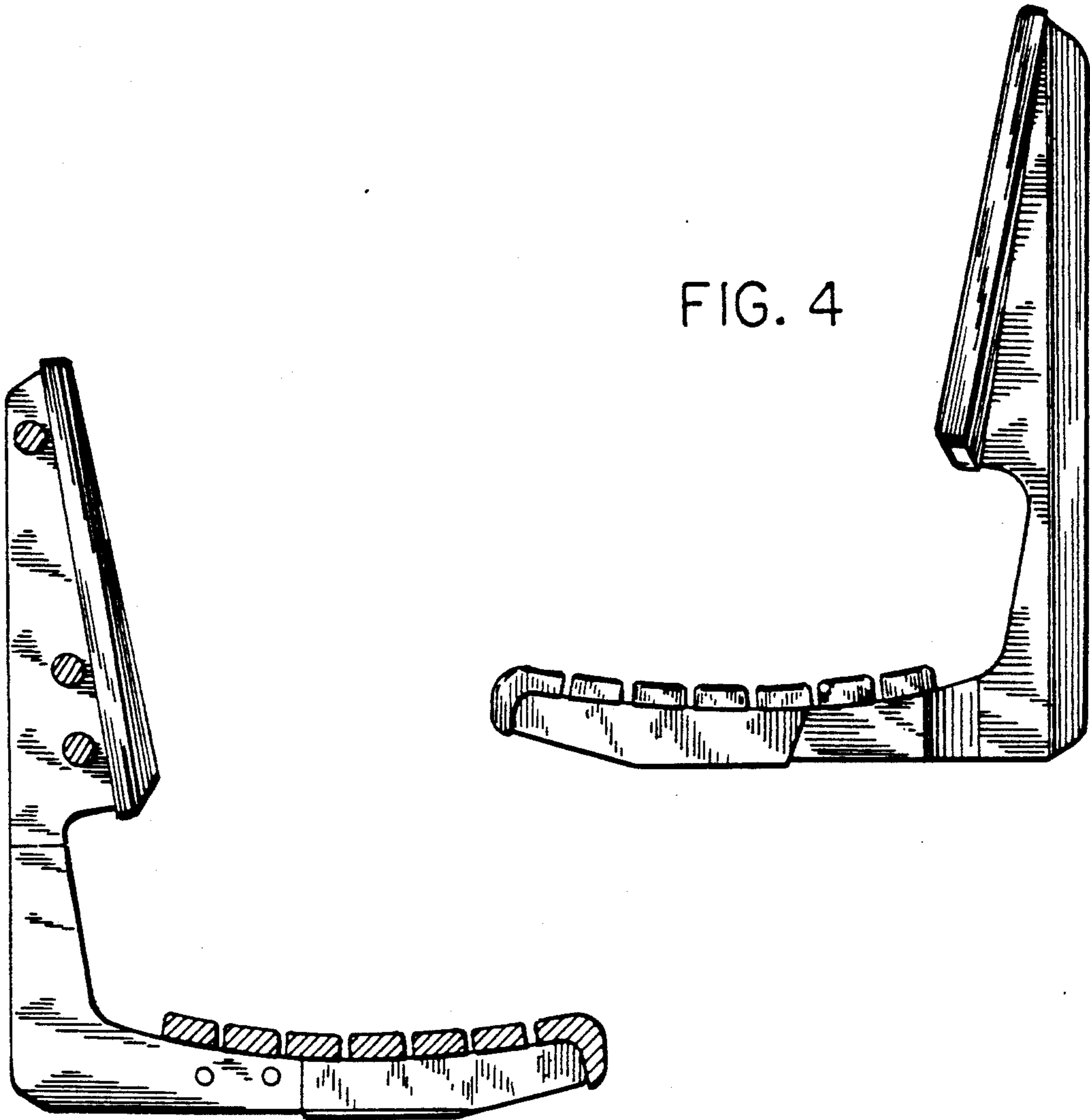

FIG. 4

FIG. 5