



US00D335918S

United States Patent [19]

Glansk

[11] Patent Number: **Des. 335,918**

[45] Date of Patent: **** May 25, 1993**

[54] **COMBINED CHECK AND CONTROL VALVE**

[75] Inventor: **Leif Glansk, Fristad, Sweden**

[73] Assignee: **Tour & Andersson AB, Sweden**

[**] Term: **14 Years**

[21] Appl. No.: **552,596**

[22] Filed: **Jul. 13, 1990**

[30] **Foreign Application Priority Data**

Jan. 15, 1990 [SE] Sweden 900074

[52] U.S. Cl. **D23/245**

[58] Field of Search **D23/233-237, D23/244-249; 137/881, 886, 887; 251/335.3**

[56] **References Cited**

U.S. PATENT DOCUMENTS

- D. 284,989 8/1986 Fetty D23/245
- 296,984 4/1884 Mapes 137/886 X
- D. 301,915 6/1989 Fisher et al. D23/233

769,901	9/1904	Hall	137/886 X
1,720,938	7/1929	Veenschoten	251/326
4,078,728	3/1978	Nordeen	137/881 X
4,232,695	11/1980	Roberge	251/335.3 X
4,237,920	12/1980	Norman	251/335.3 X
4,270,727	6/1981	Norman	251/335.3 X

Primary Examiner—James R. Largen
Attorney, Agent, or Firm—Davis, Bujold & Streck

[57] CLAIM

The ornamental design for combined check and control valve, as shown.

DESCRIPTION

FIG. 1 is a left side elevational view of a combined check and control valve showing my new design; FIG. 2 is a bottom plan view thereof; FIG. 3 is a top plan view thereof; FIG. 4 is a right end elevational view thereof; FIG. 5 is a left end elevational view thereof; and, FIG. 6 is a perspective view taken from the top, right side and right end thereof.

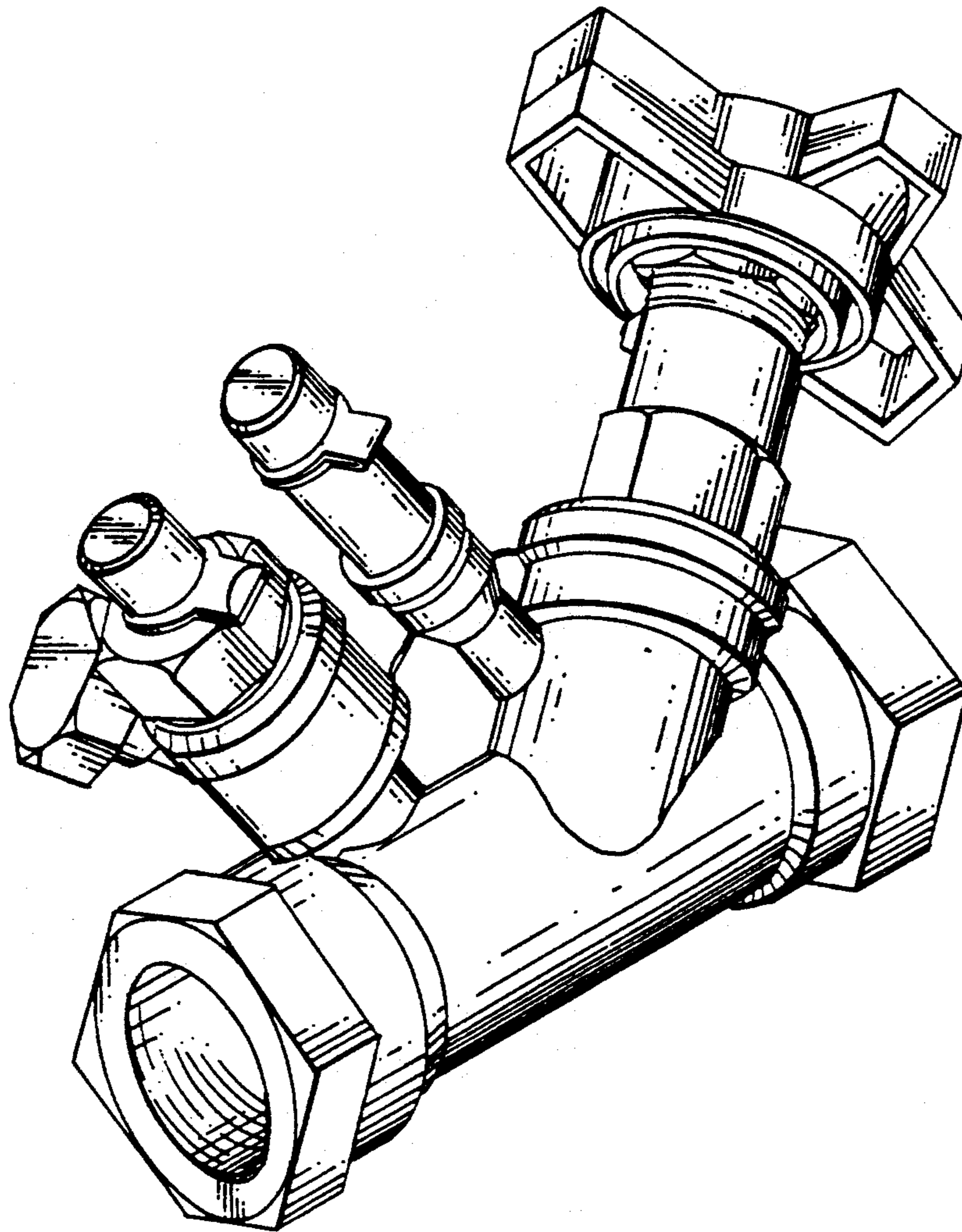

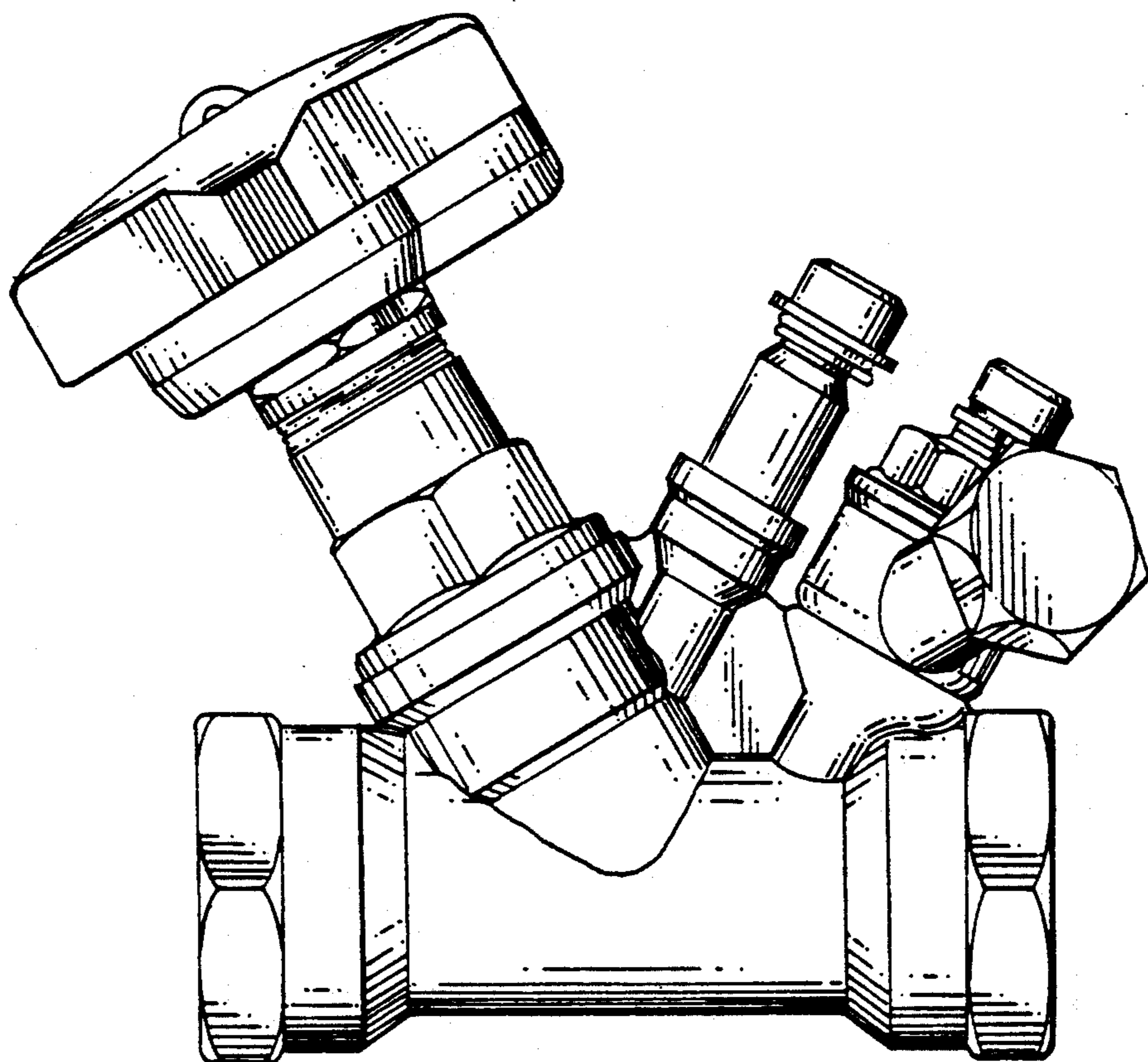
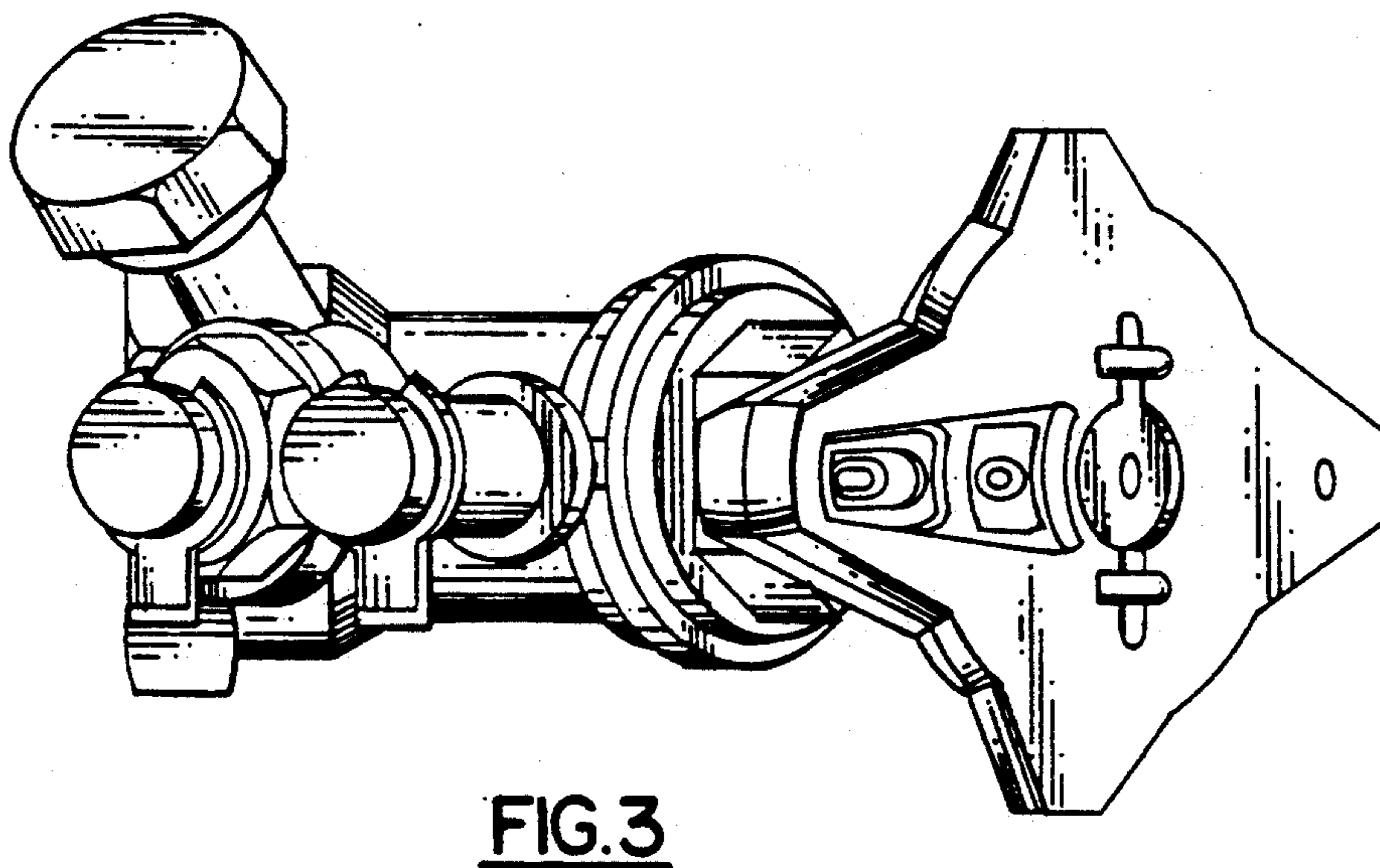
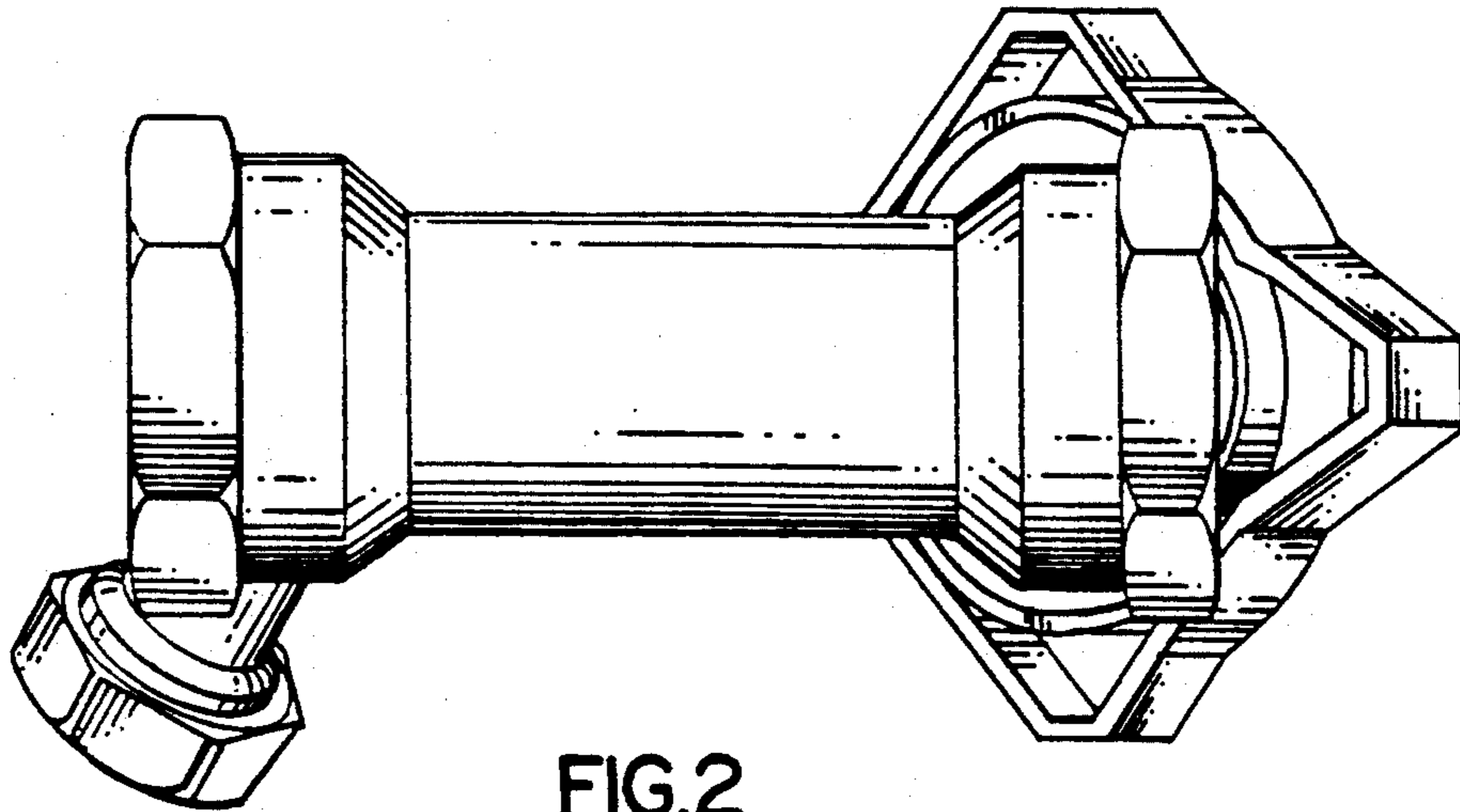

FIG. 1



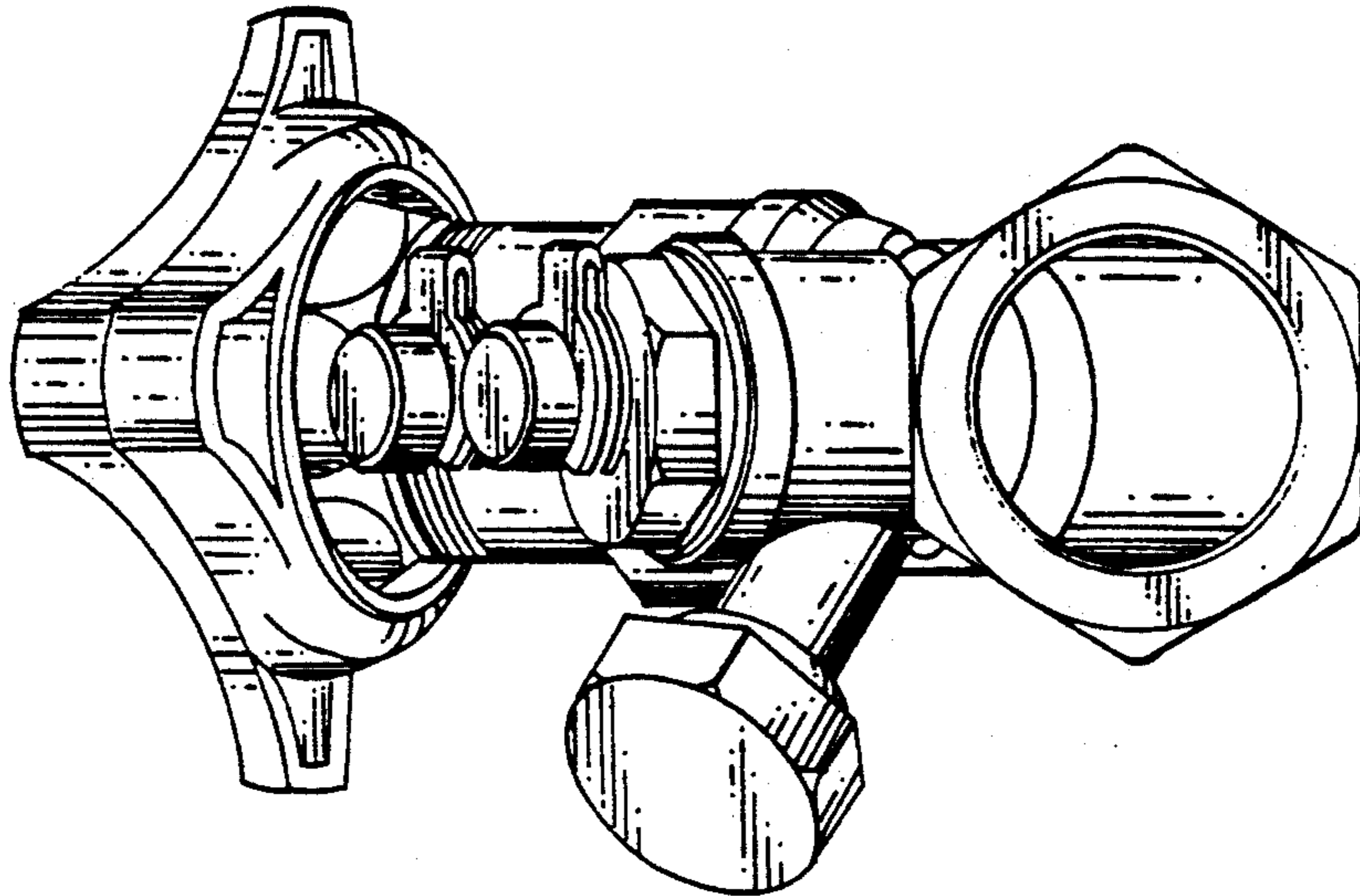

FIG. 4

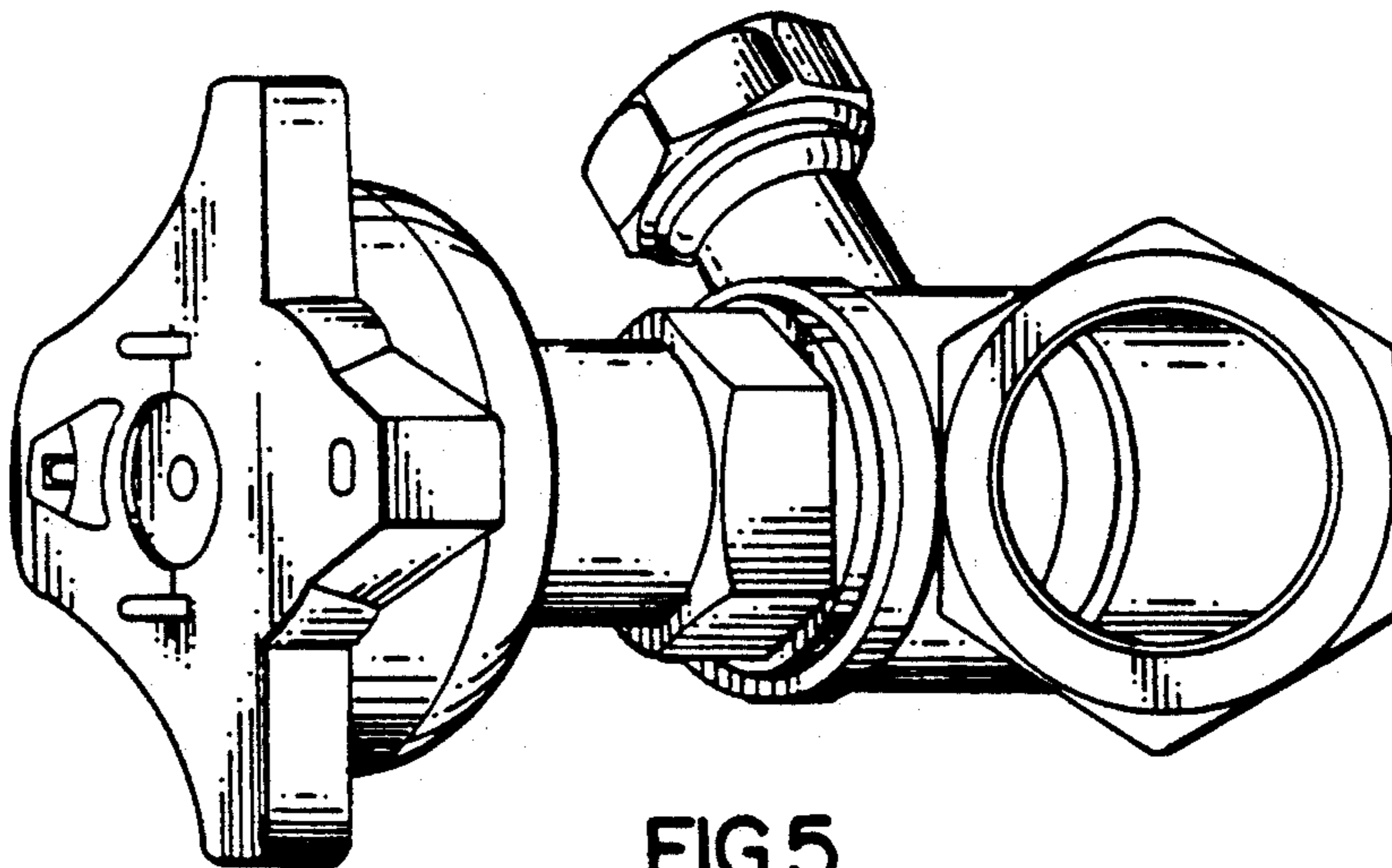

FIG. 5

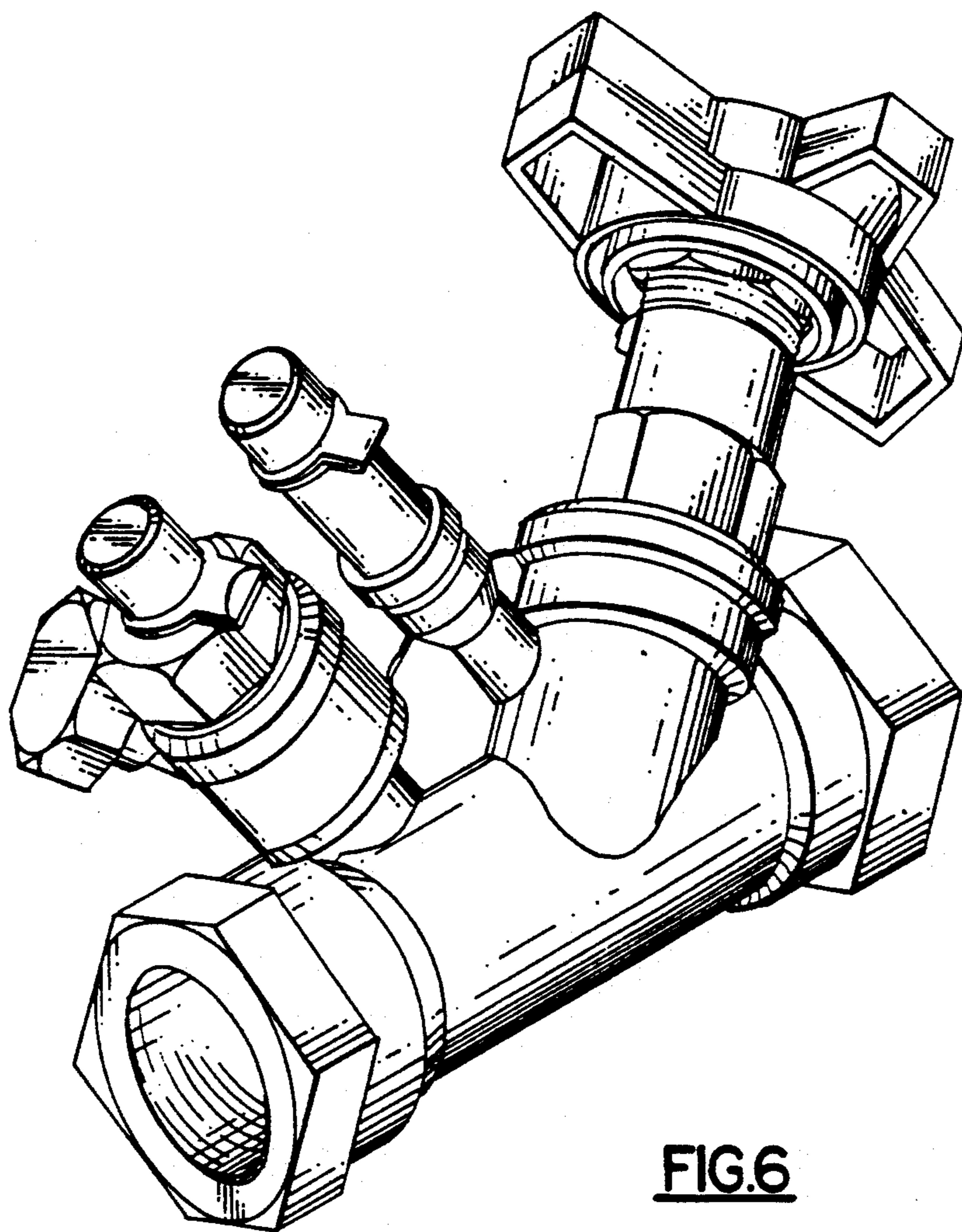

FIG. 6