



US00D335767S

United States Patent [19]

[11] Patent Number: **Des. 335,767**

Yates

[45] Date of Patent: **** May 25, 1993**

[54] **AUTOMOTIVE MUG CADDY**

[76] Inventor: **Ellen L. Yates, 1824 E. Cleveland Blvd., Caldwell, Id. 83605**

[**] Term: **14 Years**

[21] Appl. No.: **579,490**

[22] Filed: **Sep. 10, 1990**

[52] U.S. Cl. **D3/40**

[58] Field of Search **D3/40, 35; D7/620, 623, D7/625; D12/155; 108/44-46; 224/42.11, 42.42, 308, 311, 318, 273, 275, 327, 329; 296/37.1, 37.5, 37.8, 37.12; D11/143, 155**

[56] **References Cited**

U.S. PATENT DOCUMENTS

- D. 198,538 6/1964 Stricklin D3/40
- D. 232,870 9/1974 Wooster D3/40
- D. 275,543 9/1984 Borgstede, Jr. D7/620

- D. 281,614 12/1985 Carpenter et al. D3/40 X
- D. 307,355 1/1990 Page, Jr. D3/35 X
- D. 319,730 9/1991 Steenson D3/40
- D. 326,830 6/1992 Vaughn D11/143
- 3,135,392 6/1964 Elkins D7/620 X
- 3,379,316 4/1968 Harrell D3/40 X

Primary Examiner—Louis S. Zarfaz
Attorney, Agent, or Firm—Frank J. Dykas; Craig M. Korfanta; Ken J. Pedersen

[57] **CLAIM**

The ornamental design for a automotive mug caddy, as shown and described.

DESCRIPTION

FIG. 1 is a perspective view of an automotive mug caddy showing my new design; FIG. 2 is a side elevational view; FIG. 3 is an end elevational view; FIG. 4 is a top plan view; and, FIG. 5 is a bottom plan view.

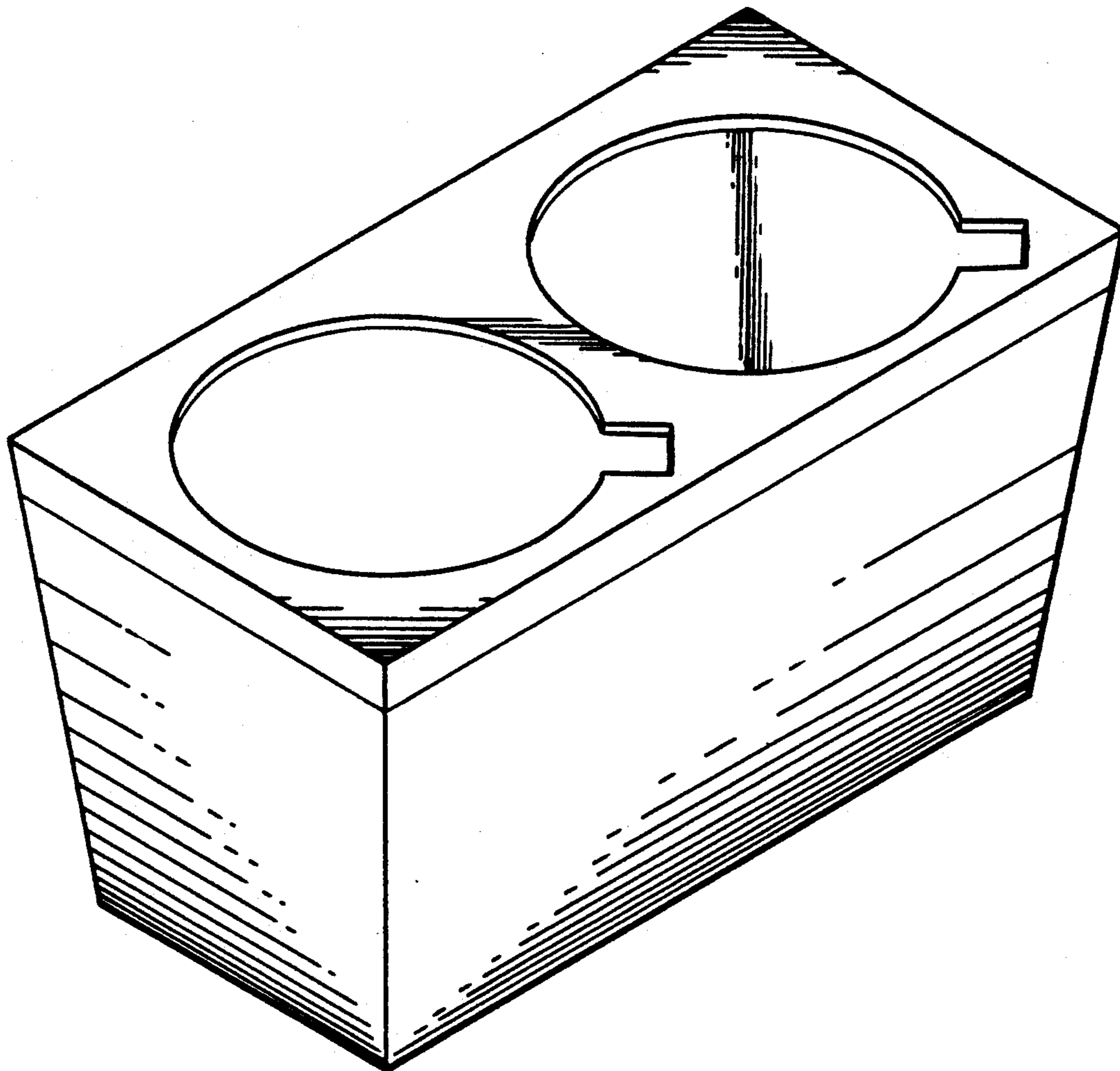

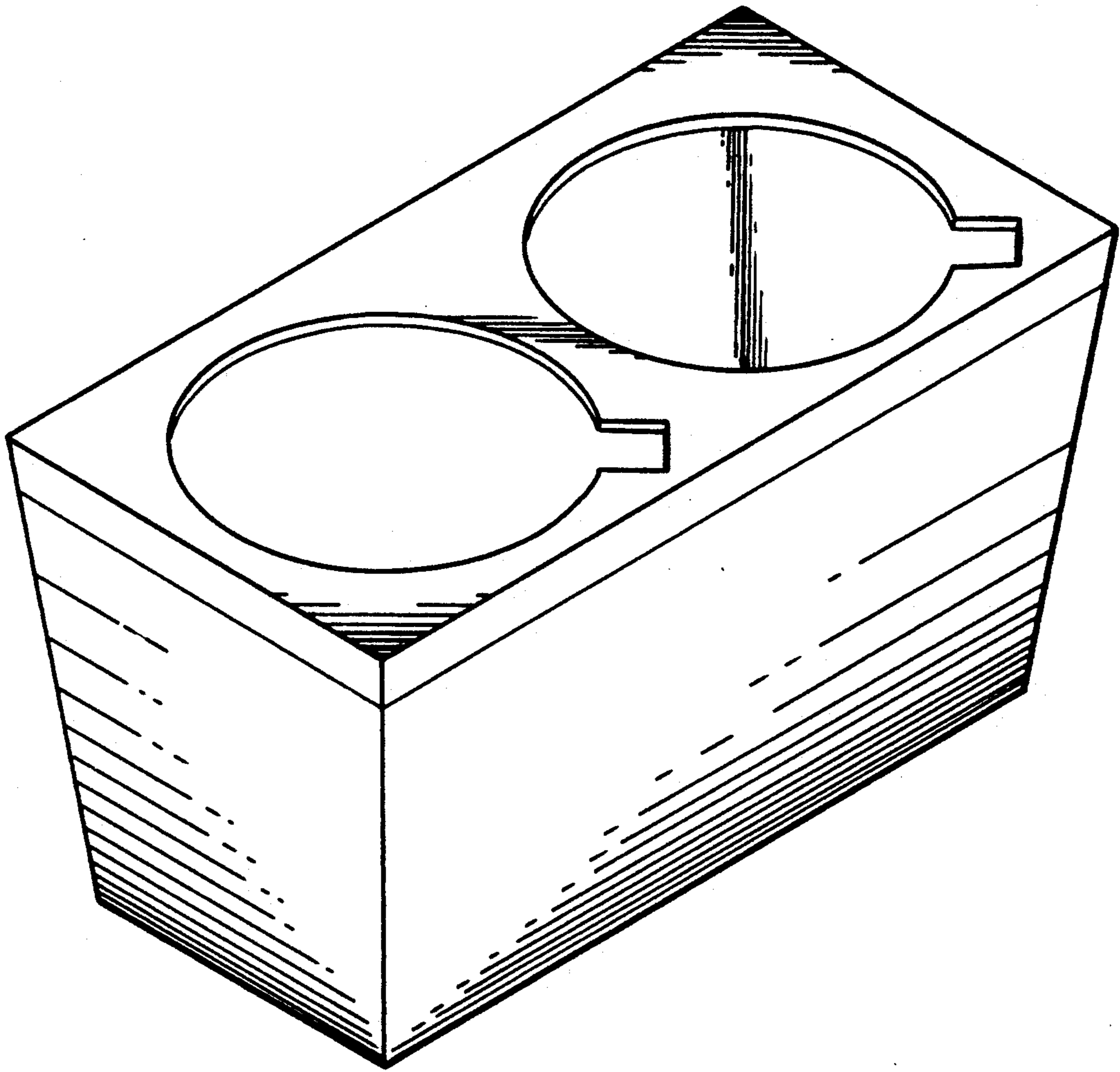

FIG. 1

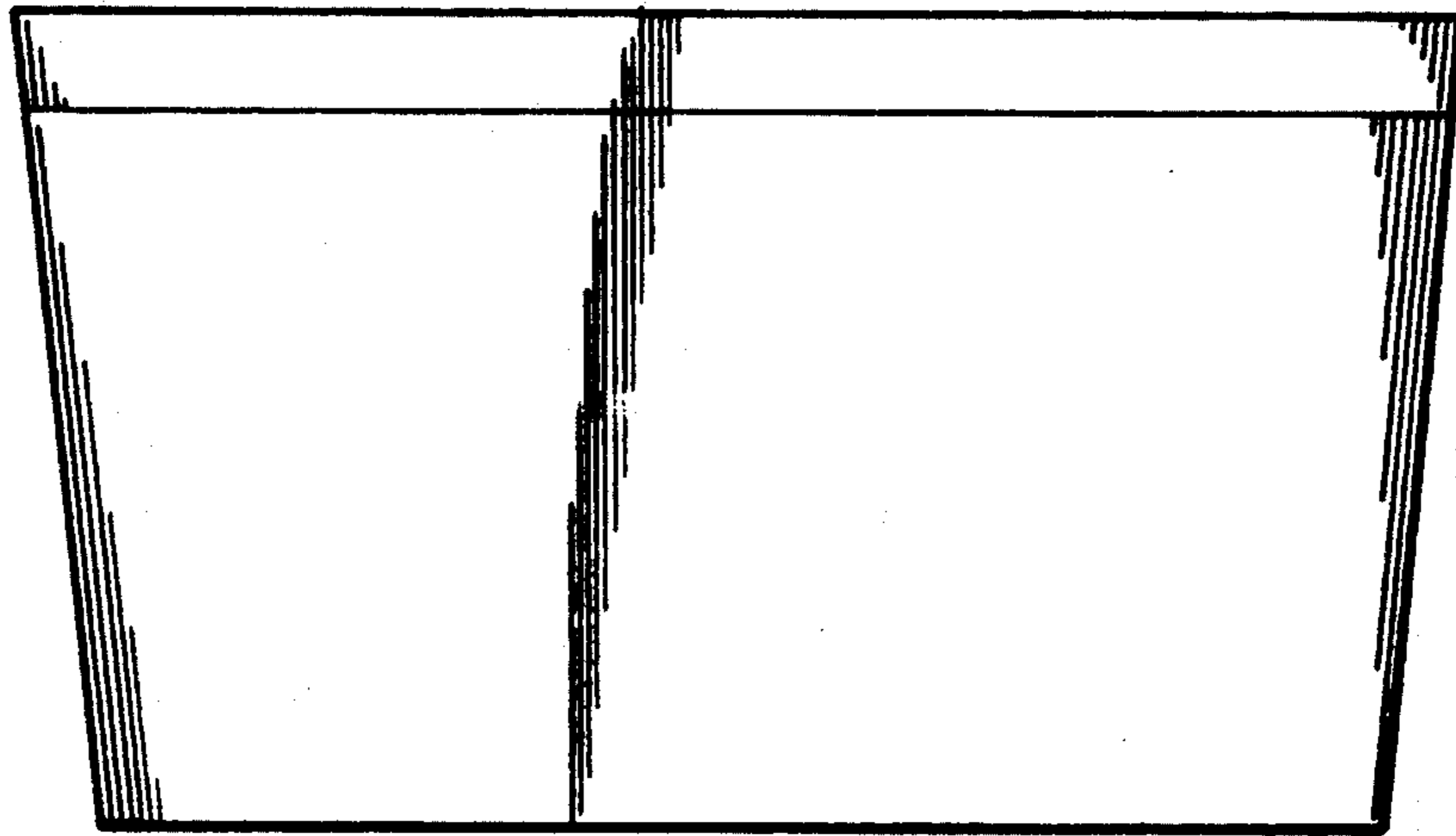

FIG. 2

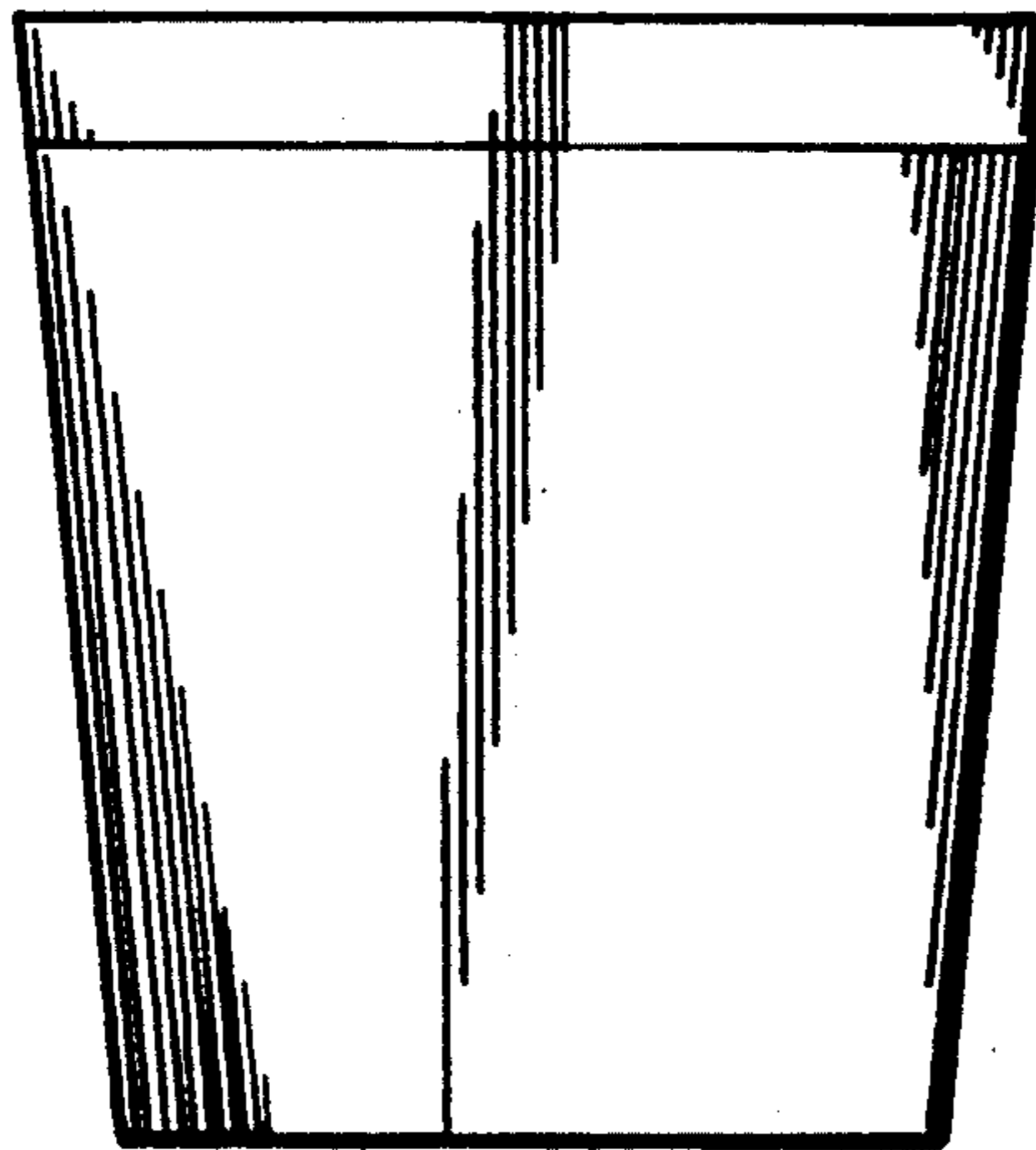

FIG. 3

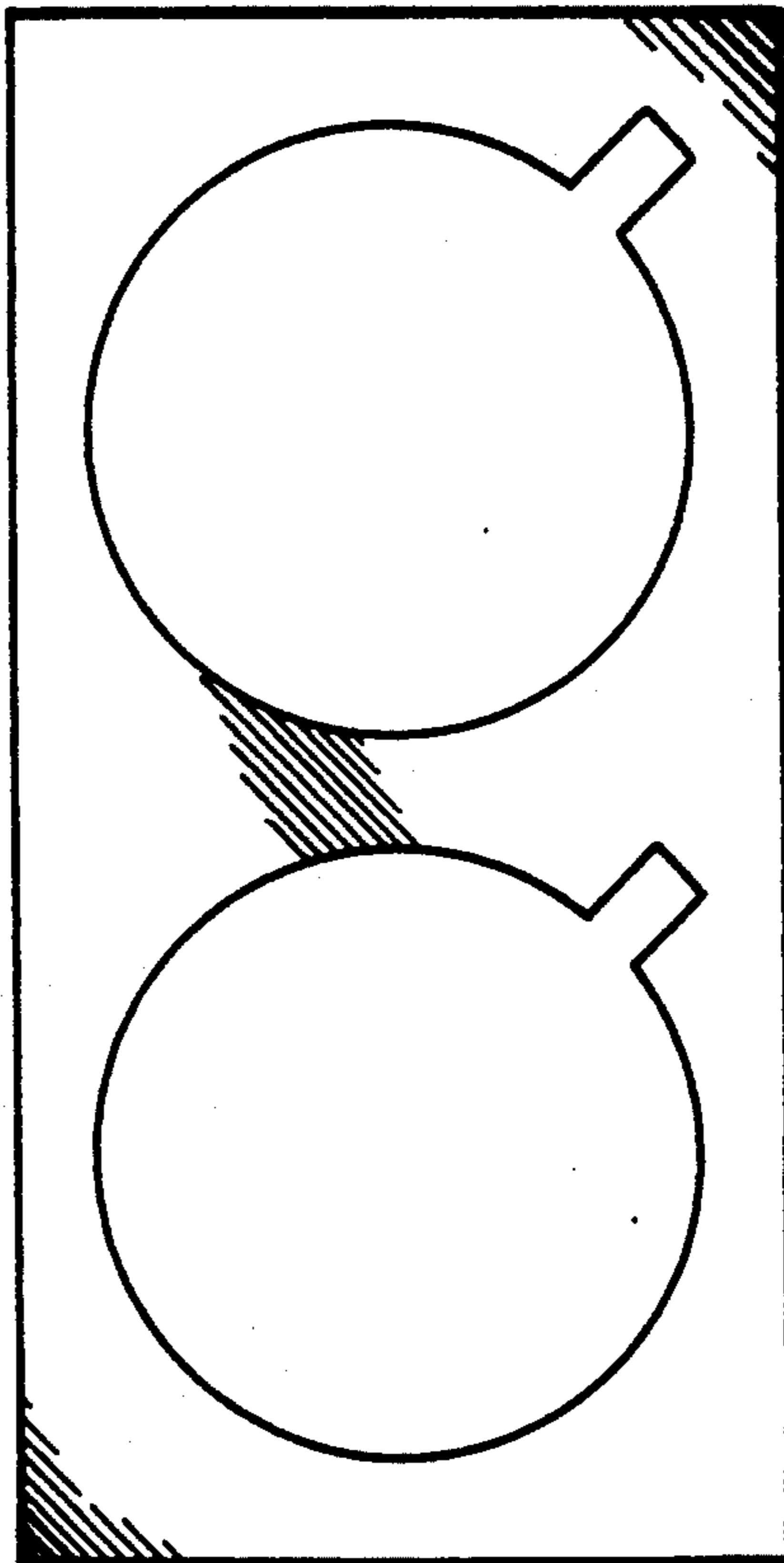

FIG. 4

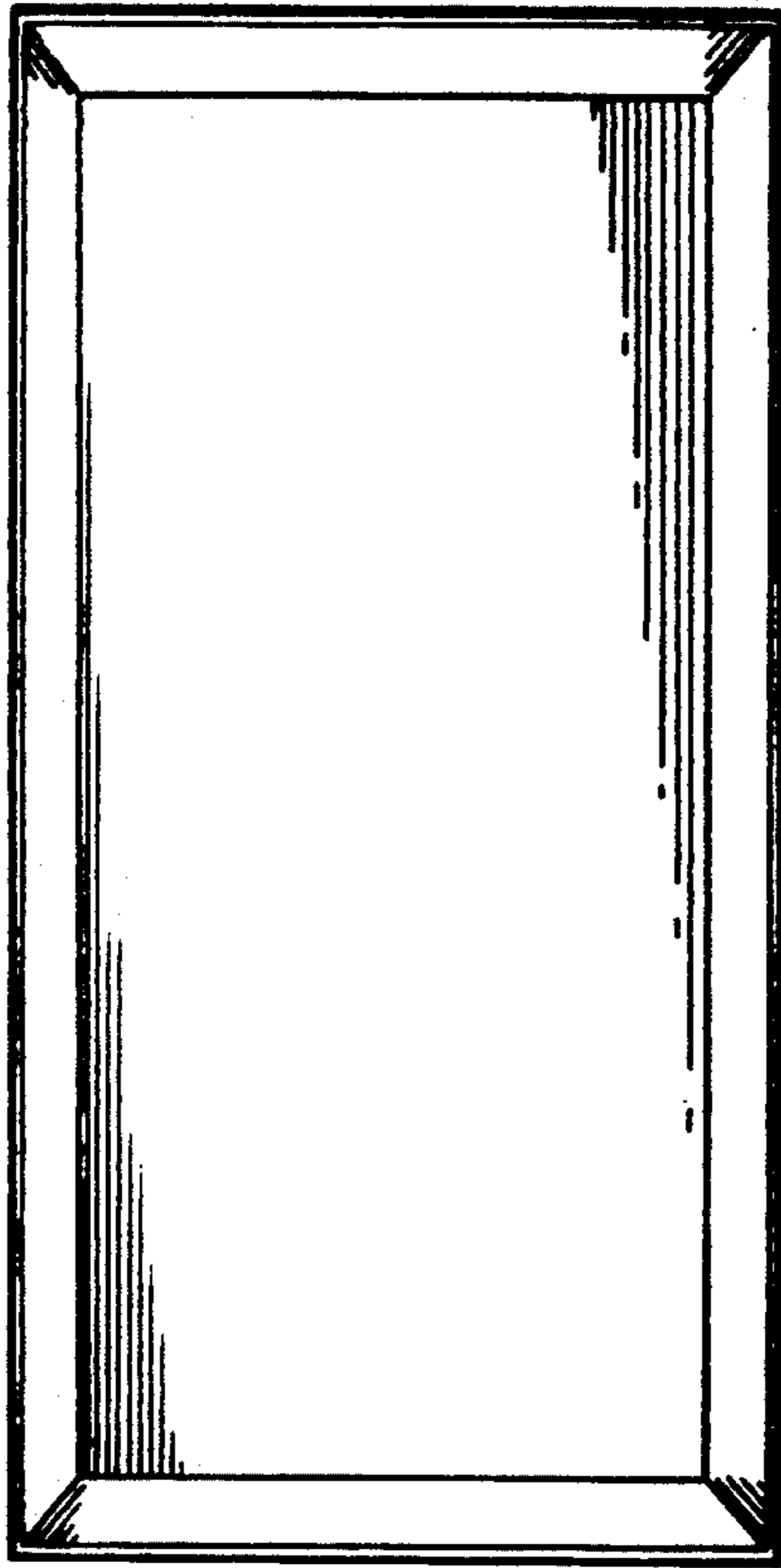

FIG. 5