



US00D335647S

United States Patent [19]

[11] Patent Number: **Des. 335,647**

Hood

[45] Date of Patent: **** May 18, 1993**

[54] **BATTERY CONNECTOR COVER**

4,920,018	4/1990	Turner	439/522 X
4,952,168	8/1990	Schieferly et al.	439/467
4,952,171	8/1990	Sugiyama	439/522
5,021,305	6/1991	Turner	429/65

[75] Inventor: **Brian M. Hood, Mount Clemens, Mich.**

[73] Assignee: **United Technologies Automotive, Dearborn, Mich.**

Primary Examiner—Wallace R. Burke
Assistant Examiner—J. Sincavage
Attorney, Agent, or Firm—Ronald G. Cummings

[**] Term: **14 Years**

[57] CLAIM

[21] Appl. No.: **767,310**

The ornamental design for a battery connector cover, as shown and described.

[22] Filed: **Sep. 27, 1991**

[52] U.S. Cl. **D13/119**

DESCRIPTION

[58] Field of Search **D13/118, 119, 120, 156; 439/467, 519, 521, 522, 901, 902; 174/138 F; 429/65, 121, 175**

FIG. 1 is a top view of the battery connector cover of the present invention;
FIG. 2 is a right side view;
FIG. 3 is a left side view;
FIG. 4 is a bottom view;
FIG. 5 is a rear view;
FIG. 6 is a front view; and,
FIG. 7 is a perspective view of the battery connector cover of the present invention mounted atop an automobile battery (shown in broken line and broken away) and attached to a battery connector (not shown) with a battery cable (shown in broken line and broken away) extending therefrom.

[56] References Cited

U.S. PATENT DOCUMENTS

D. 244,864	6/1977	Brooks	D13/119
D. 316,398	4/1991	Hill	D13/120
2,145,135	1/1939	Ryalls	173/259
2,671,819	3/1954	Field	429/65
2,800,522	7/1957	Coleman et al.	429/65
3,014,977	12/1961	Geiser	439/521 X
3,829,823	8/1974	Dumesnil	439/522
4,562,125	12/1985	Davis	429/65
4,698,459	10/1987	Drake	174/138
4,775,331	10/1988	Magdesyan et al.	439/522 X
4,778,408	10/1988	Morrison	439/522

The broken lines illustrate the environment in which the battery connector cover is used and are not part of the design thereof.

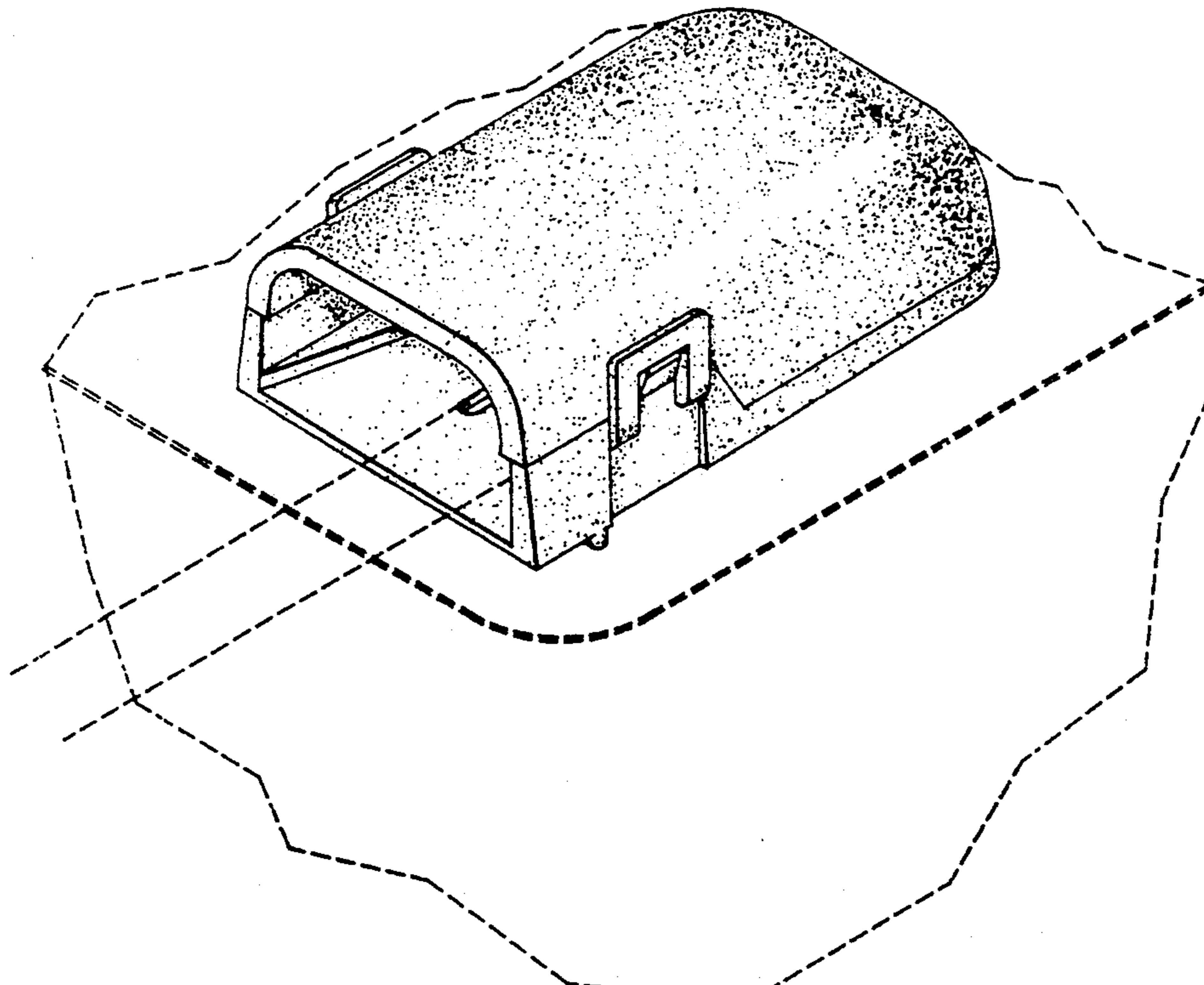

FIG.7

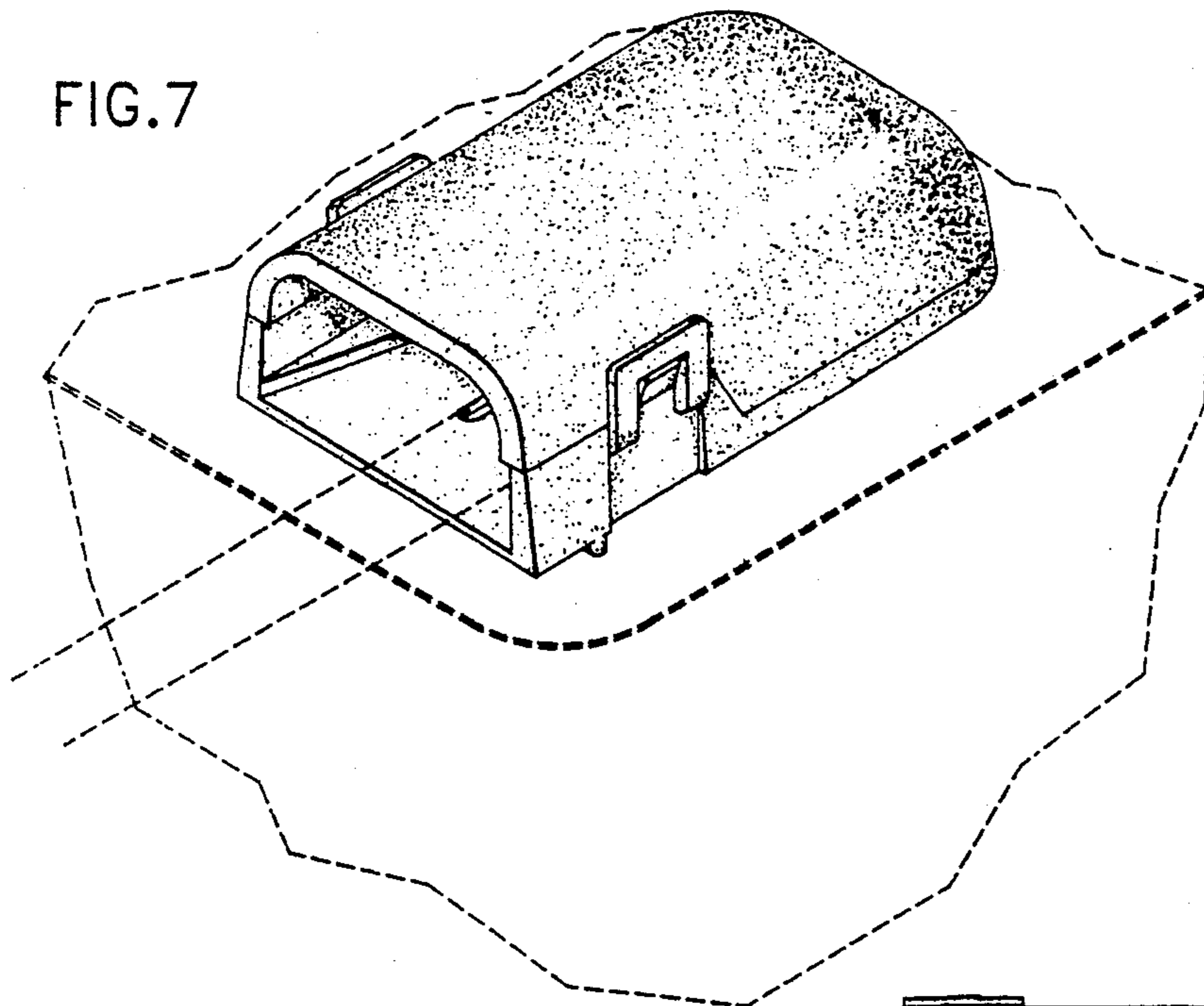

FIG.1

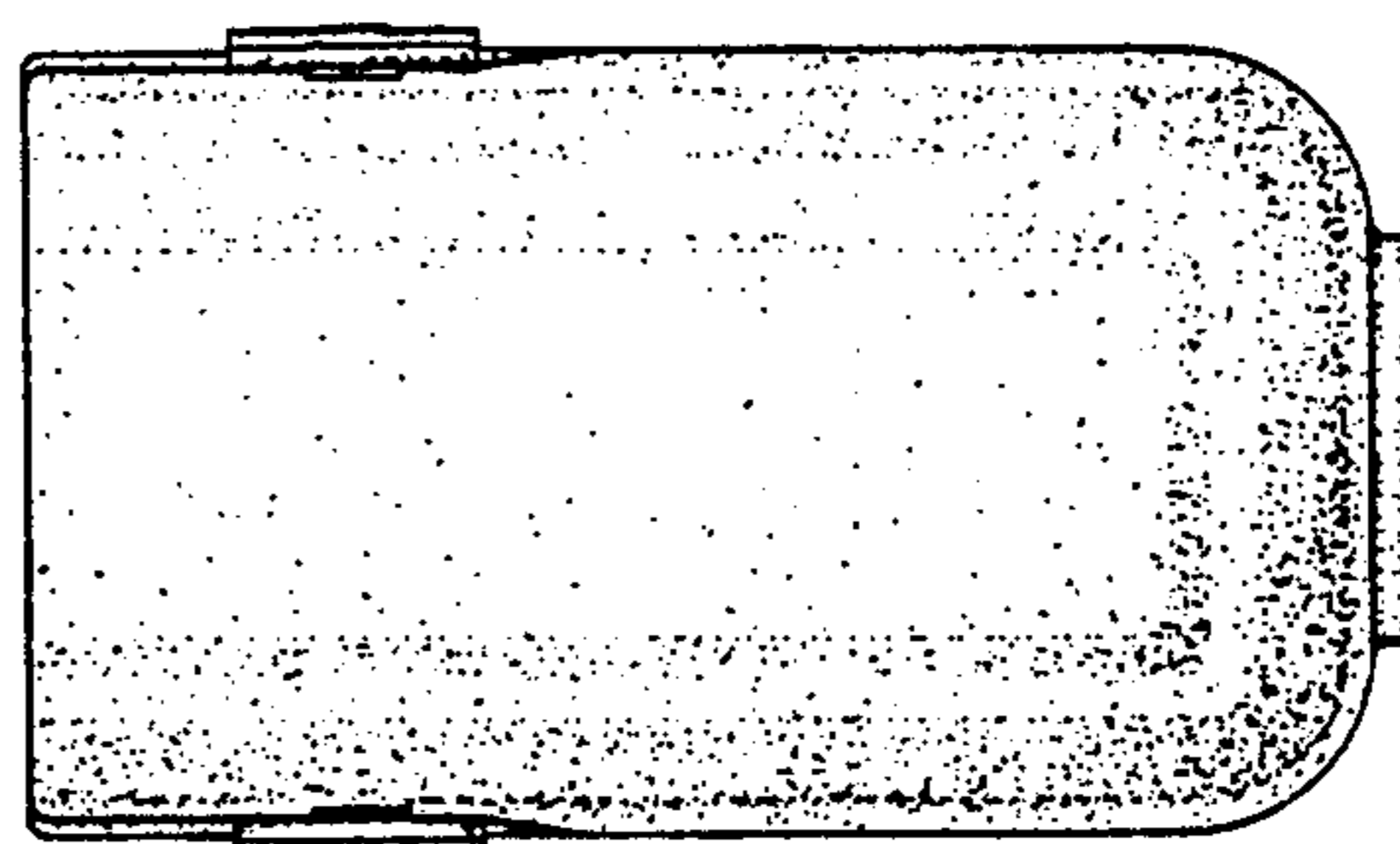

FIG.5

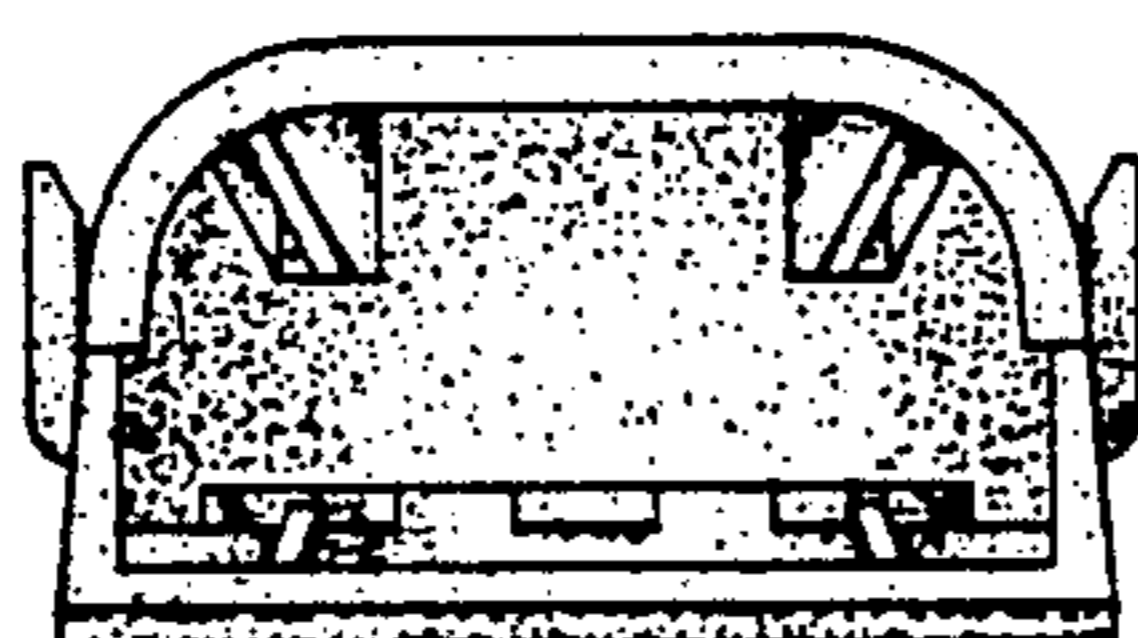

FIG.2

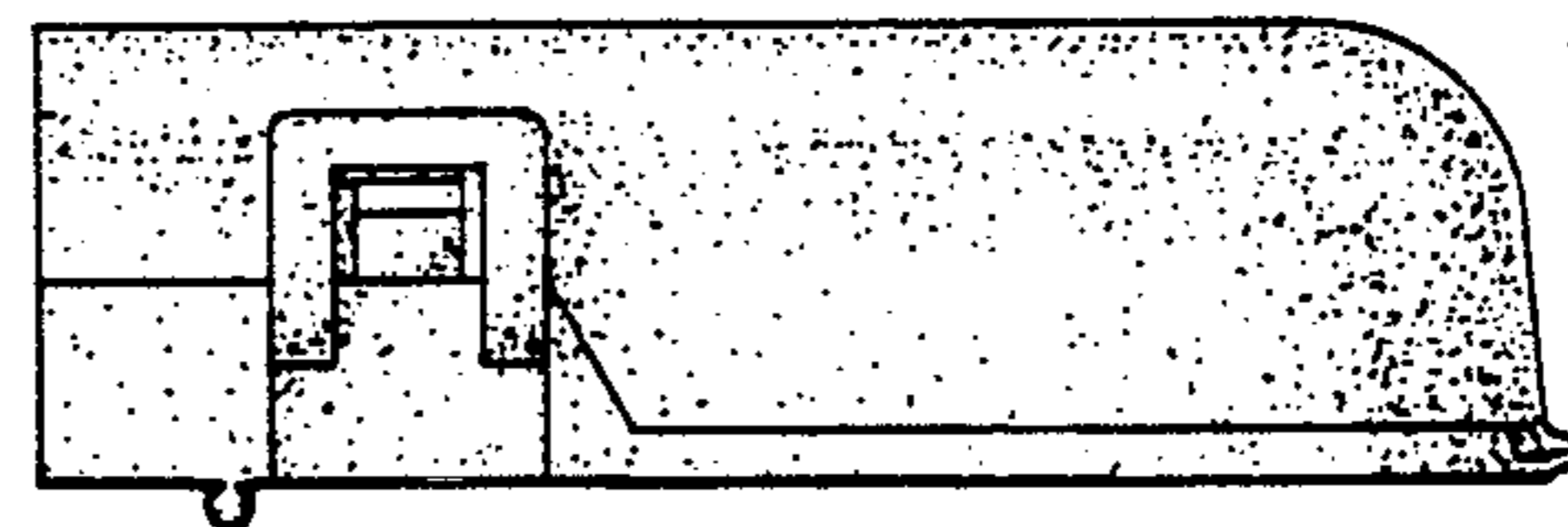

FIG.6

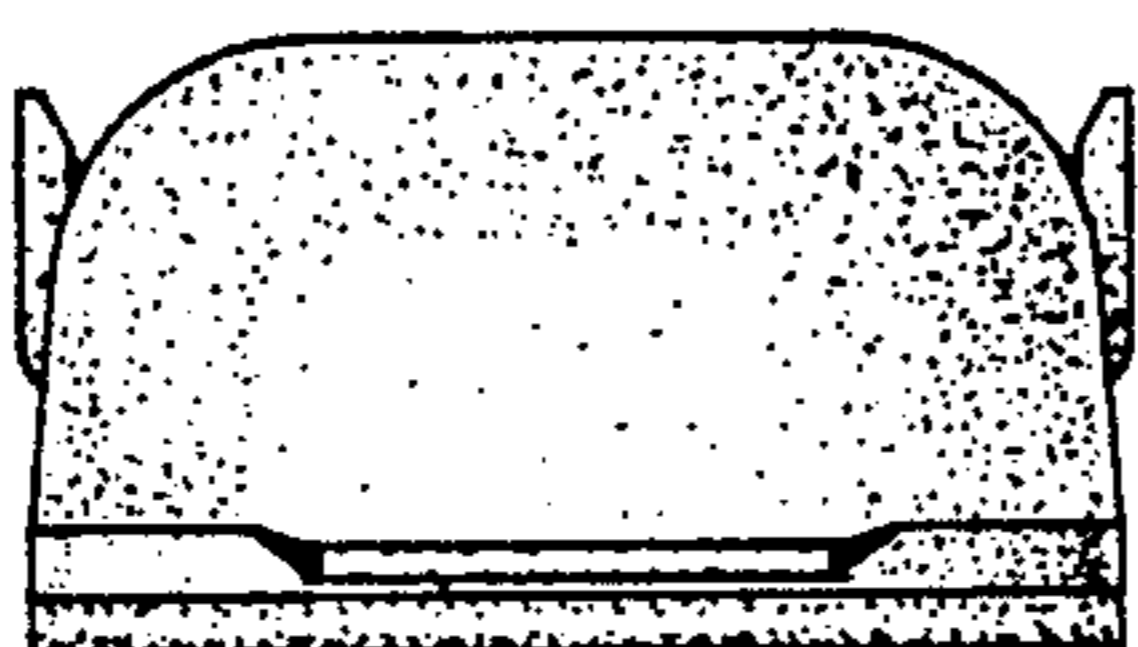

FIG.3

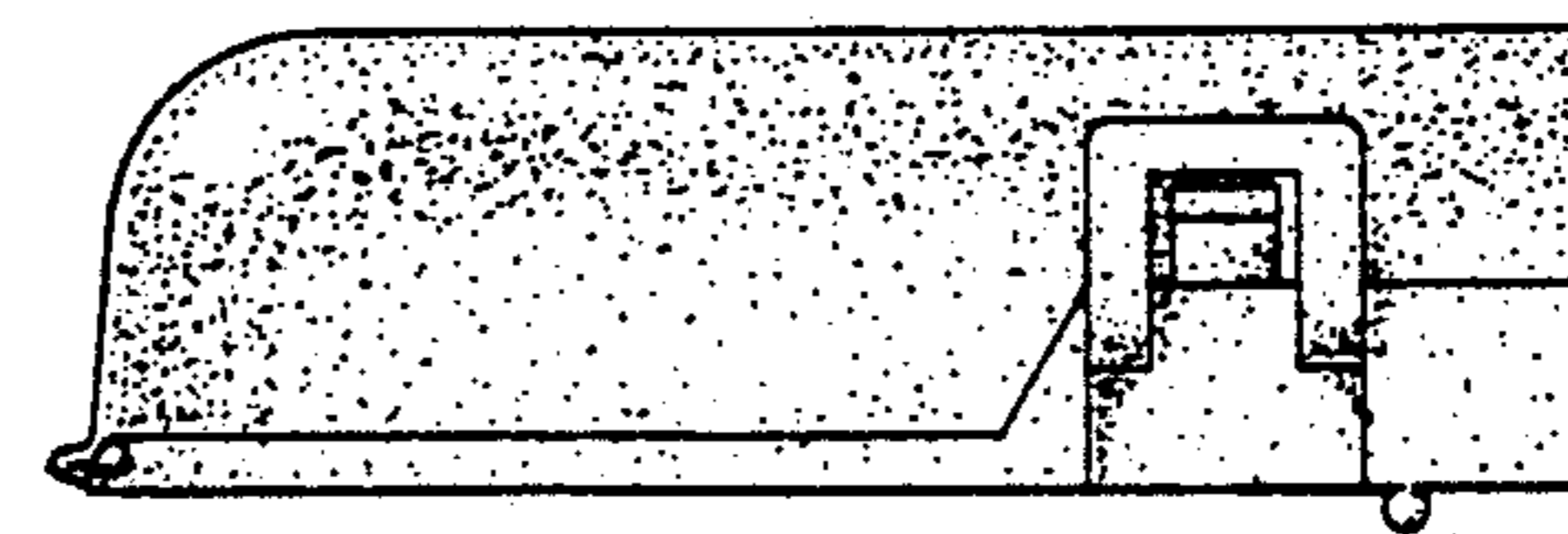

FIG.4

