



US00D335640S

# United States Patent [19]

[11] Patent Number: **Des. 335,640**

**Gasiorowski**

[45] Date of Patent: **\*\* May 18, 1993**

## [54] BICYCLE FRAME

[76] Inventor: **Roman J. Gasiorowski, 4434 Steffani La., Houston, Tex. 77041**

[\*\*] Term: **14 Years**

[21] Appl. No.: **573,655**

[22] Filed: **Aug. 24, 1990**

[52] U.S. Cl. .... **D12/111**

[58] Field of Search ..... **D12/111; 280/281.1, 280/288.1, 288.2, 288.3, 284, 274**

## [56] References Cited

### U.S. PATENT DOCUMENTS

D. 34,254	3/1901	Sangster	.....	D12/111
D. 143,572	1/1946	Bruce	.....	D12/111
D. 146,437	3/1947	Taylor	.....	D12/111
D. 235,249	6/1975	Kitsuda	.....	D12/111
D. 303,777	10/1989	Levine	.....	D12/111
D. 320,962	10/1991	Savage	.....	D12/111
D. 321,156	10/1991	Browning	.....	D12/111
112,875	1/1839	DaRos	.....	229/35 R
148,531	2/1848	Fletcher	.....	431/174
191,754	11/1861	Musichuk	.....	280/286
210,059	1/1868	Oakley	.....	D12/111
218,999	10/1870	Ross et al.	.....	280/281
283,606	4/1886	Moulton	.....	D12/111
437,026	9/1890	Flachs	.....	280/274
442,275	12/1890	Rothgiesser	.....	280/274
447,434	3/1891	Latta	.....	280/274
476,974	6/1892	Bolte	.....	280/281.1
616,383	12/1898	Willatt	.....	280/274
633,127	9/1899	Duffy	.....	280/274
683,381	9/1901	Chamberlin	.....	280/281
694,567	3/1902	Moore	.....	280/281.1
2,244,709	6/1941	Kinzel	.....	280/281
3,448,997	6/1969	Kosugi	.....	280/281
4,500,103	2/1985	Klein	.....	280/281
4,647,060	3/1987	Tomkinson	.....	280/281
4,666,175	5/1987	Mueller	.....	280/291

## FOREIGN PATENT DOCUMENTS

869277	1/1942	France .
897769	3/1945	France .
1080852	12/1954	France .
400957	12/1942	Italy .
2117333	10/1983	United Kingdom .

## OTHER PUBLICATIONS

American Bicyclist and Motorcyclist, Aug. 1990, pp. 37 & 82, The San Joint and Fuh MTB Frame Model No. YF-900.

*Primary Examiner*—Wallace R. Burke

*Assistant Examiner*—Melody Brown

## [57] CLAIM

The ornamental design for a bicycle frame, as shown and described.

## DESCRIPTION

FIG. 1 is a perspective view of a bicycle frame showing my new design, it being understood that the broken lines are for illustrative purposes only and on no part of the claimed design;

FIG. 2 is a side elevation view thereof, the opposite side being a mirror image of that shown;

FIG. 3 is a top plan view thereof;

FIG. 4 is a side elevation view of a bicycle frame showing a second embodiment of my new design, the opposite side being a mirror image of that shown;

FIG. 5 is a top plan view of FIG. 4;

FIG. 6 is a cross-section view taken along line 6—6 in FIGS. 2, 3, 4, 5 and 9;

FIG. 7 is a cross-section view taken along line 7—7 in FIGS. 2, 3, 4, 5 and 9;

FIG. 8 is a cross-section view taken along line 8—8 in FIGS. 2, 3, 4, 8 and 9; and,

FIG. 9 is a bottom plan view of FIGS. 1 and 4.

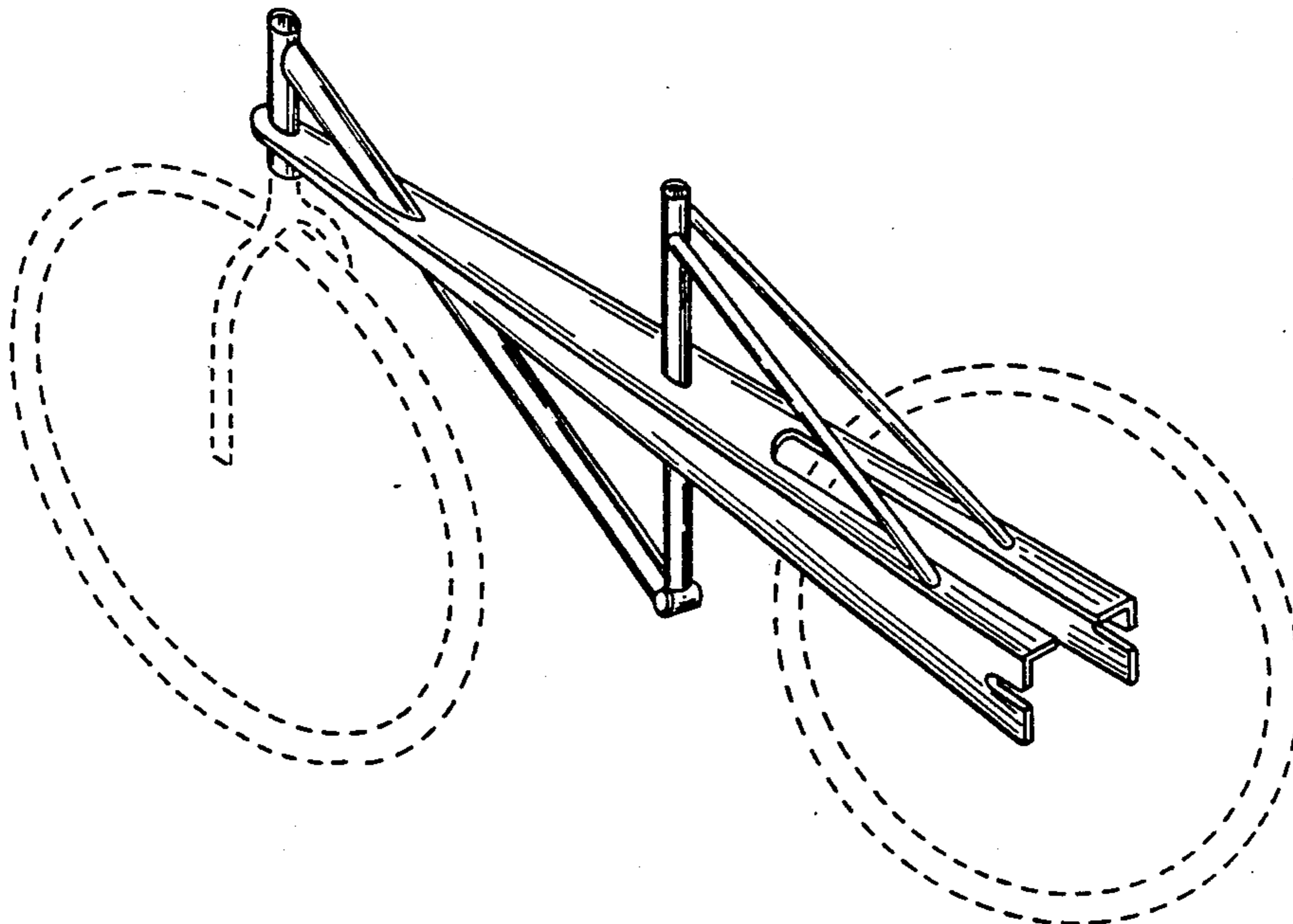

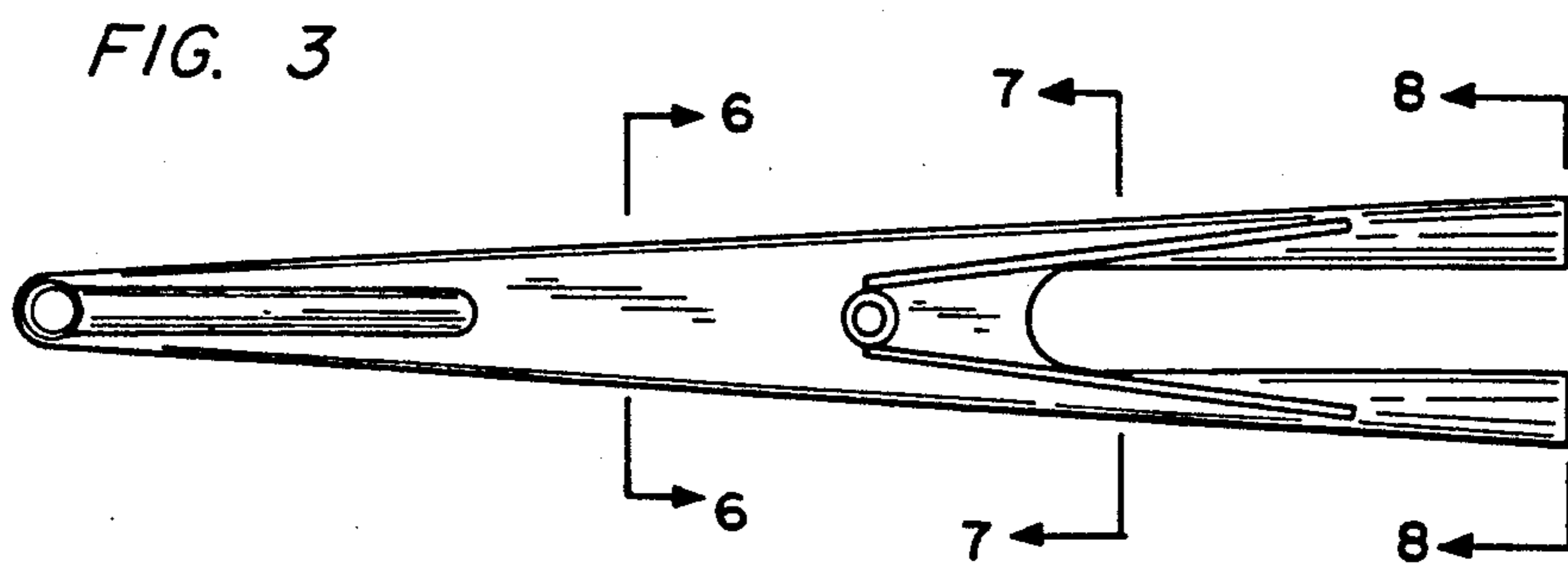
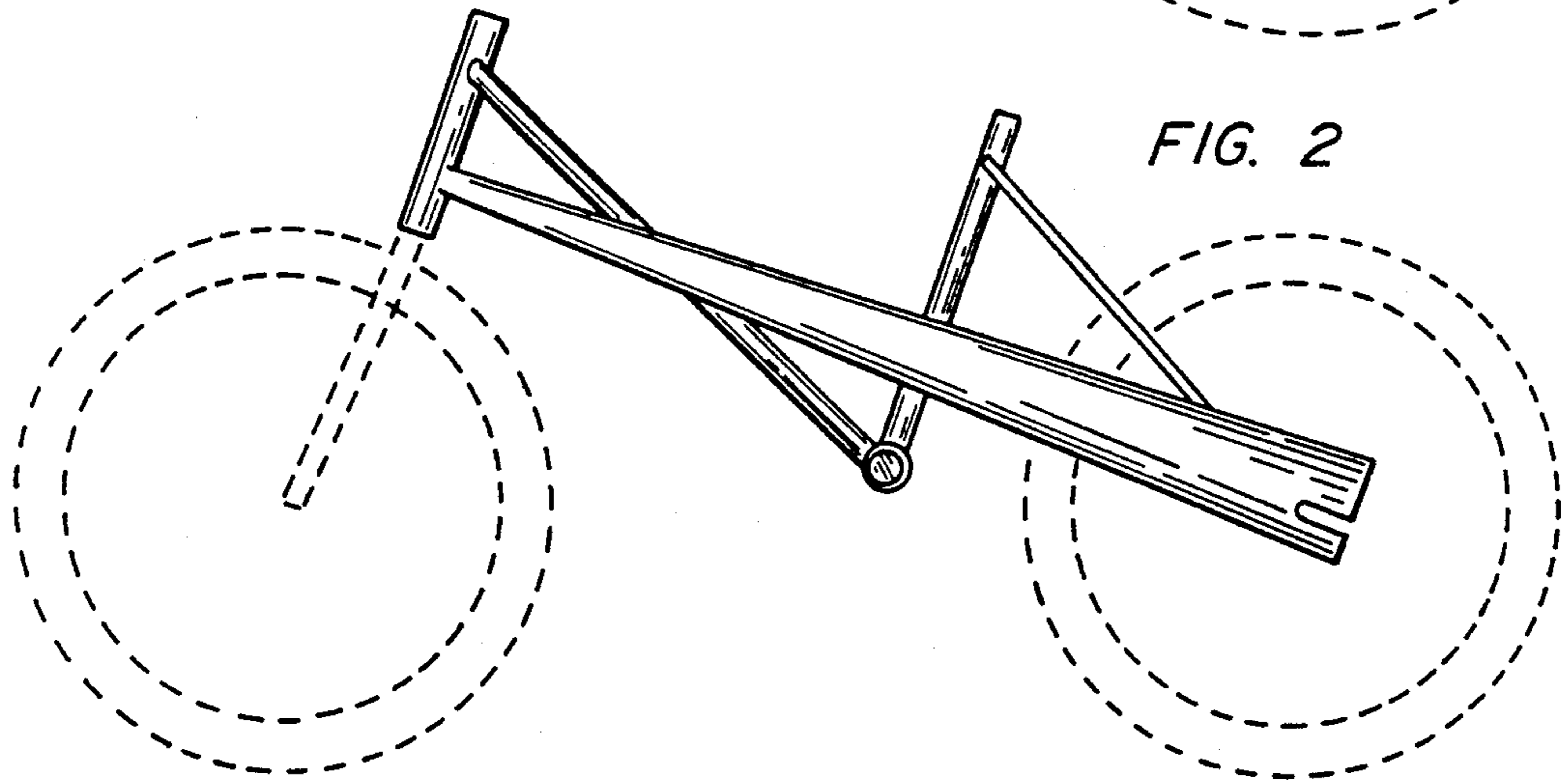
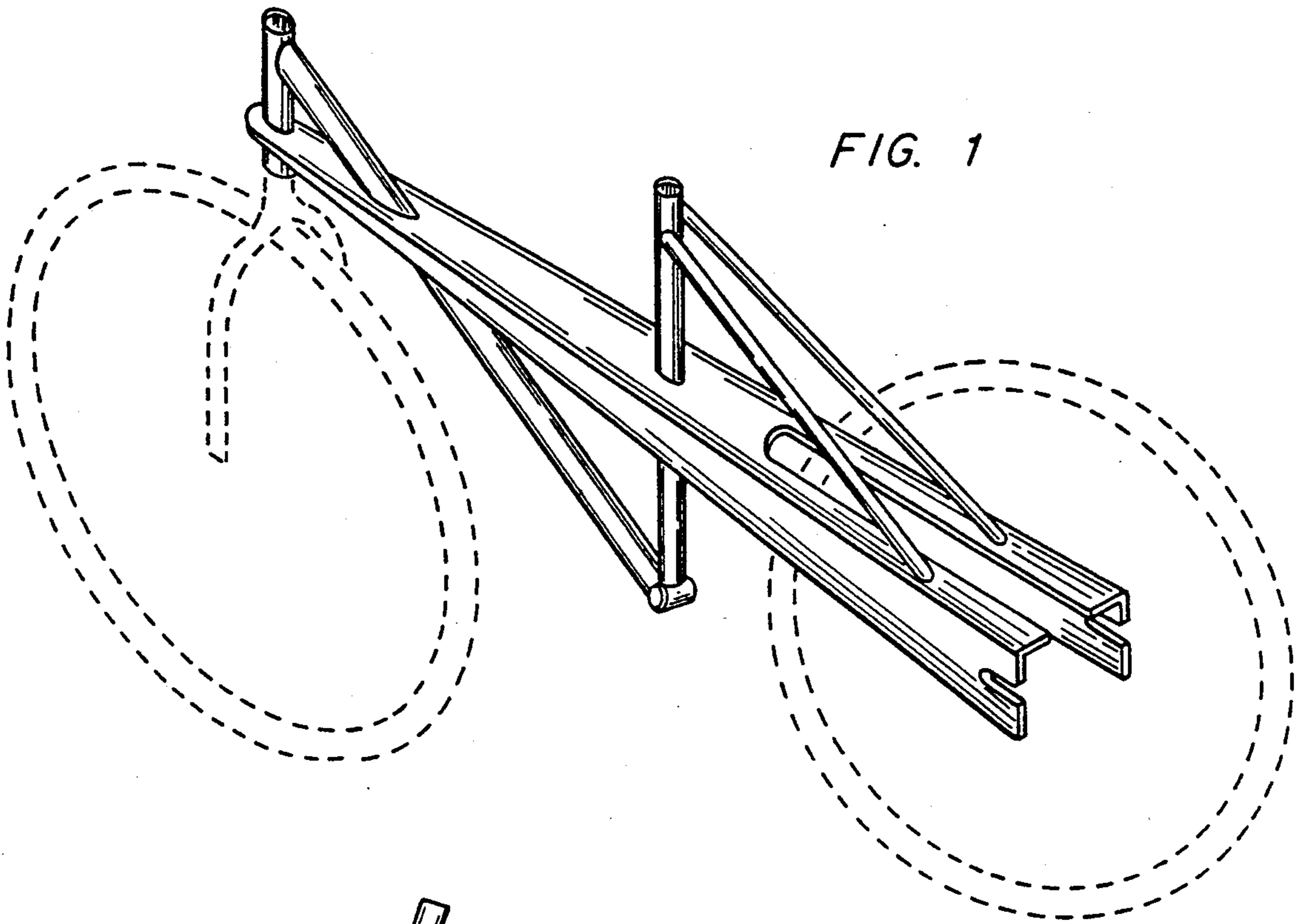

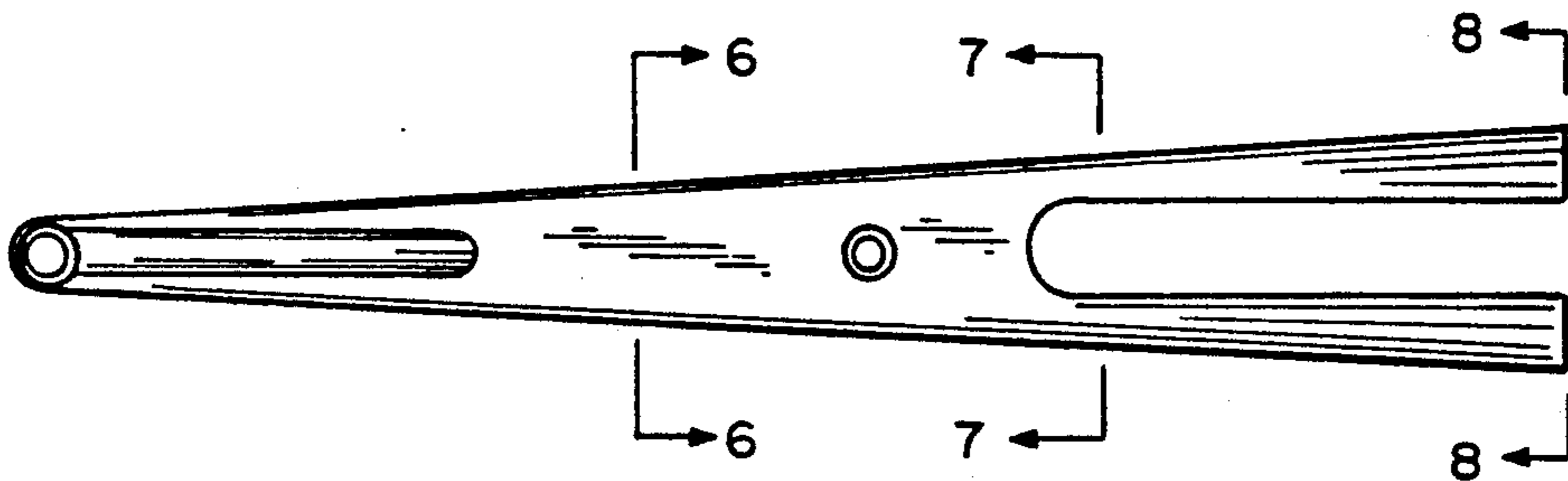
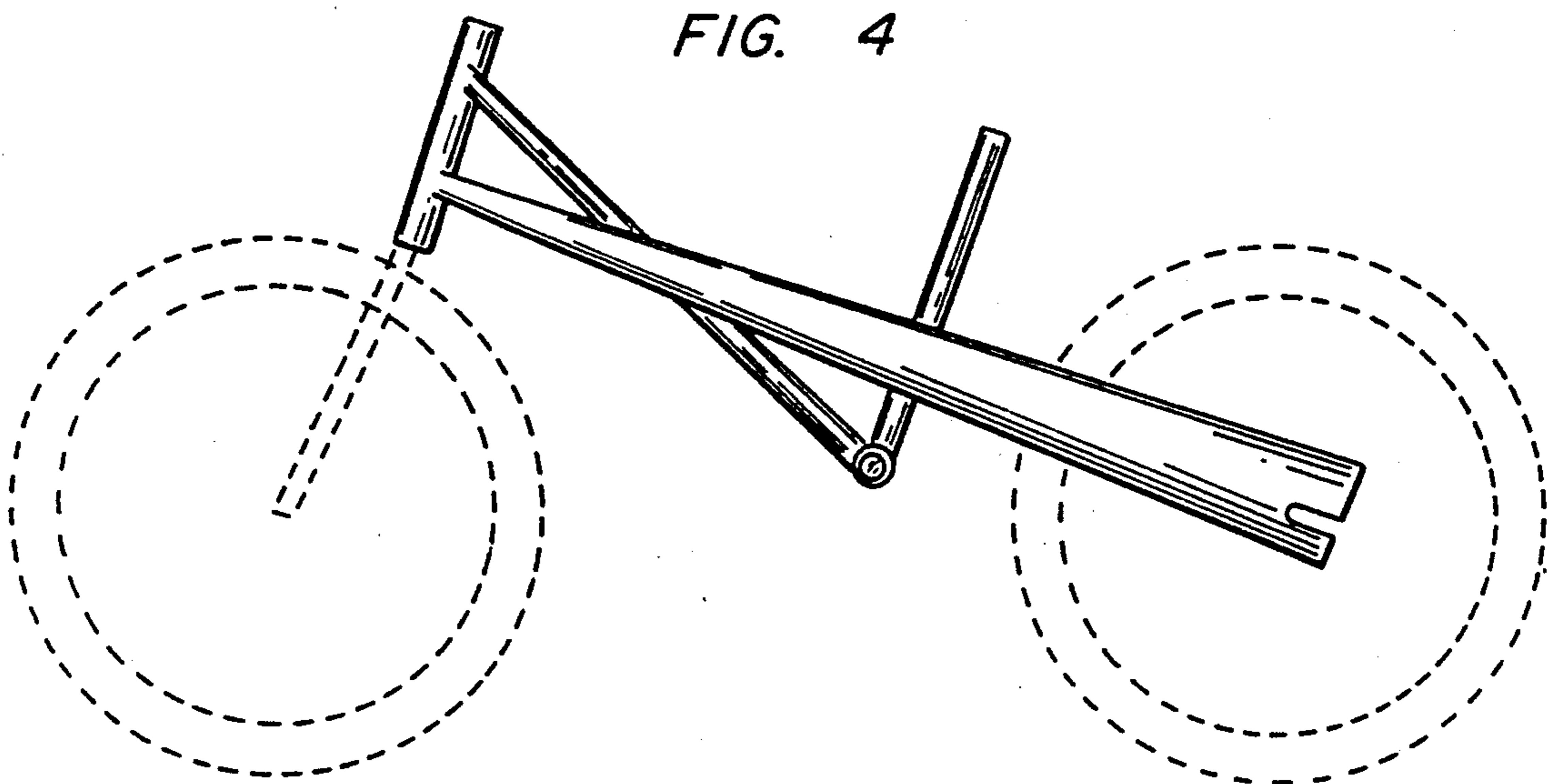

FIG. 5

FIG. 6



FIG. 7

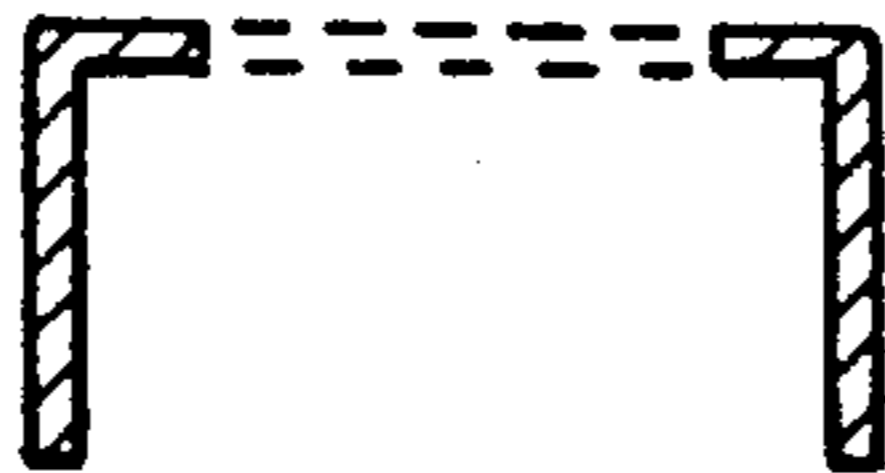

FIG. 8

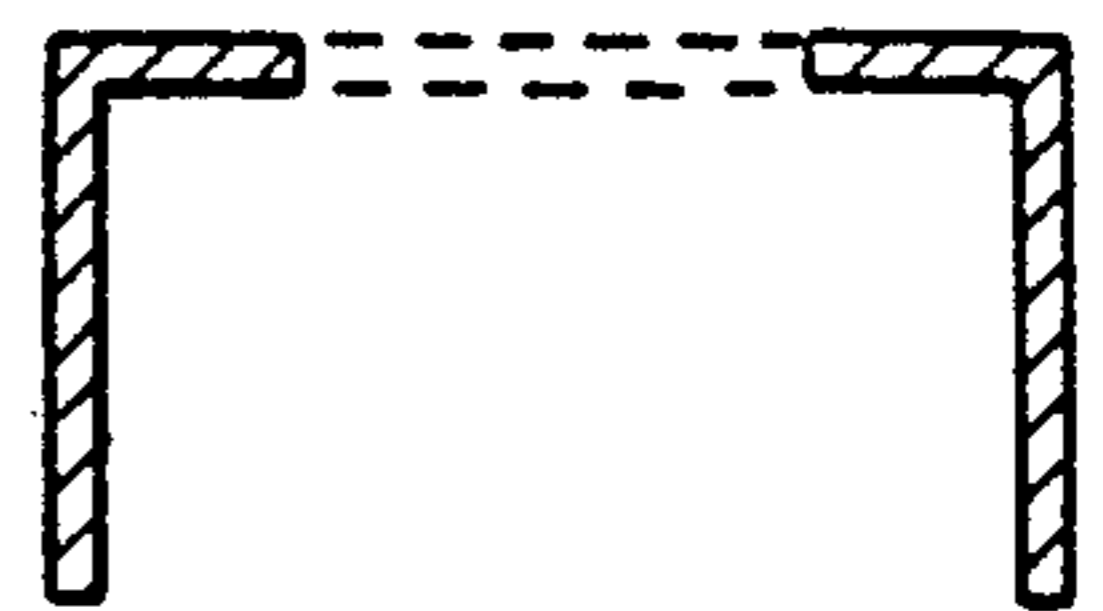

FIG. 9

