



US00D335348S

# United States Patent [19]

[11] Patent Number: **Des. 335,348**

Frenkel et al.

[45] Date of Patent: **\*\* May 4, 1993**

[54] **ASSAY MODULE MAGAZINE**

[75] Inventors: **Dina Frenkel, Plano, Tex.; Melvin S. Henriksen, Walpole, Mass.; Ernest W. Long, Concord, Mass.; Robert C. MacIndoe, Jr., Linwood, Mass.**

[73] Assignee: **PB Diagnostic Systems Inc., Westwood, Mass.**

[\*\*] Term: **14 Years**

[21] Appl. No.: **734,808**

[22] Filed: **Jul. 23, 1991**

[52] U.S. Cl. .... **D24/224; D24/226**

[58] Field of Search ..... **D24/216, 224, 225, 226, D24/227, 229; 414/417, 796.8; 422/58, 61, 62, 63, 64, 65, 66, 67**

[56] **References Cited**

**U.S. PATENT DOCUMENTS**

- Re. 30,595 4/1981 Covington et al. .... 422/63
- D. 234,088 1/1975 Grandos ..... D24/229
- D. 260,428 8/1981 Fekete ..... D24/226

- D. 266,589 10/1982 Gilford et al. .... D24/226
- D. 282,005 12/1985 Käyhkö ..... D24/226
- D. 290,170 6/1987 Käyhkö ..... D24/226
- D. 313,276 12/1990 McHugh ..... D24/227
- 4,512,952 4/1985 Blanding et al. .... 422/63
- 4,515,753 5/1985 Smith et al. .... 422/63 X
- 5,167,922 12/1992 Long ..... 422/64 X

*Primary Examiner*—Alan P. Douglas  
*Assistant Examiner*—Antoine D. Davis  
*Attorney, Agent, or Firm*—Gaetano D. Maccarone

[57] **CLAIM**

The ornamental design for an assay module magazine, as shown and described.

**DESCRIPTION**

FIG. 1 is a right front perspective view of an assay module magazine;  
FIG. 2 is a top elevational view thereof;  
FIG. 3 is a bottom elevational view thereof;  
FIG. 4 is a right side elevational view thereof;  
FIG. 5 is a left elevational view thereof;  
FIG. 6 is a front end elevational view thereof; and,  
FIG. 7 is a rear end elevation view thereof.

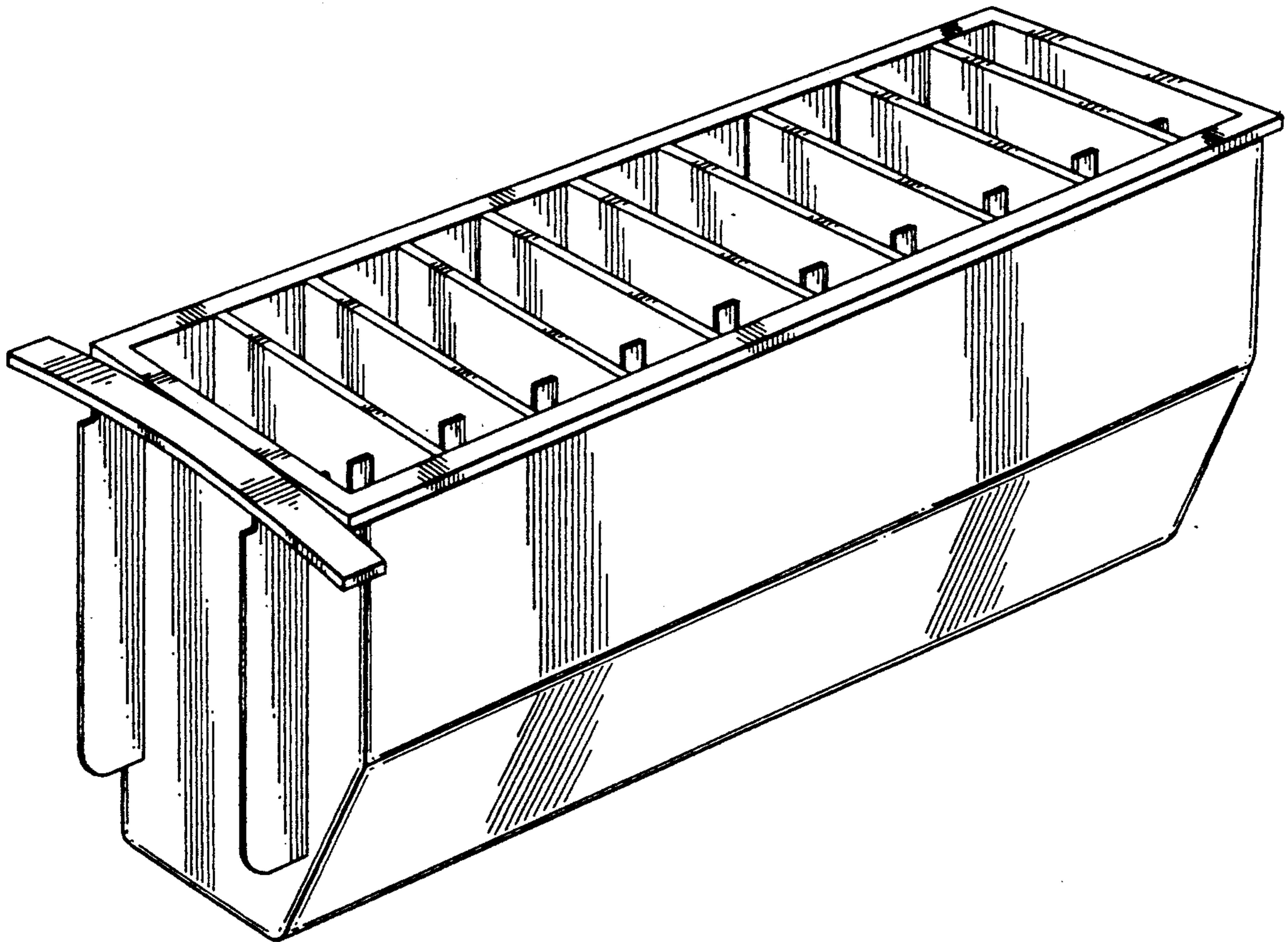

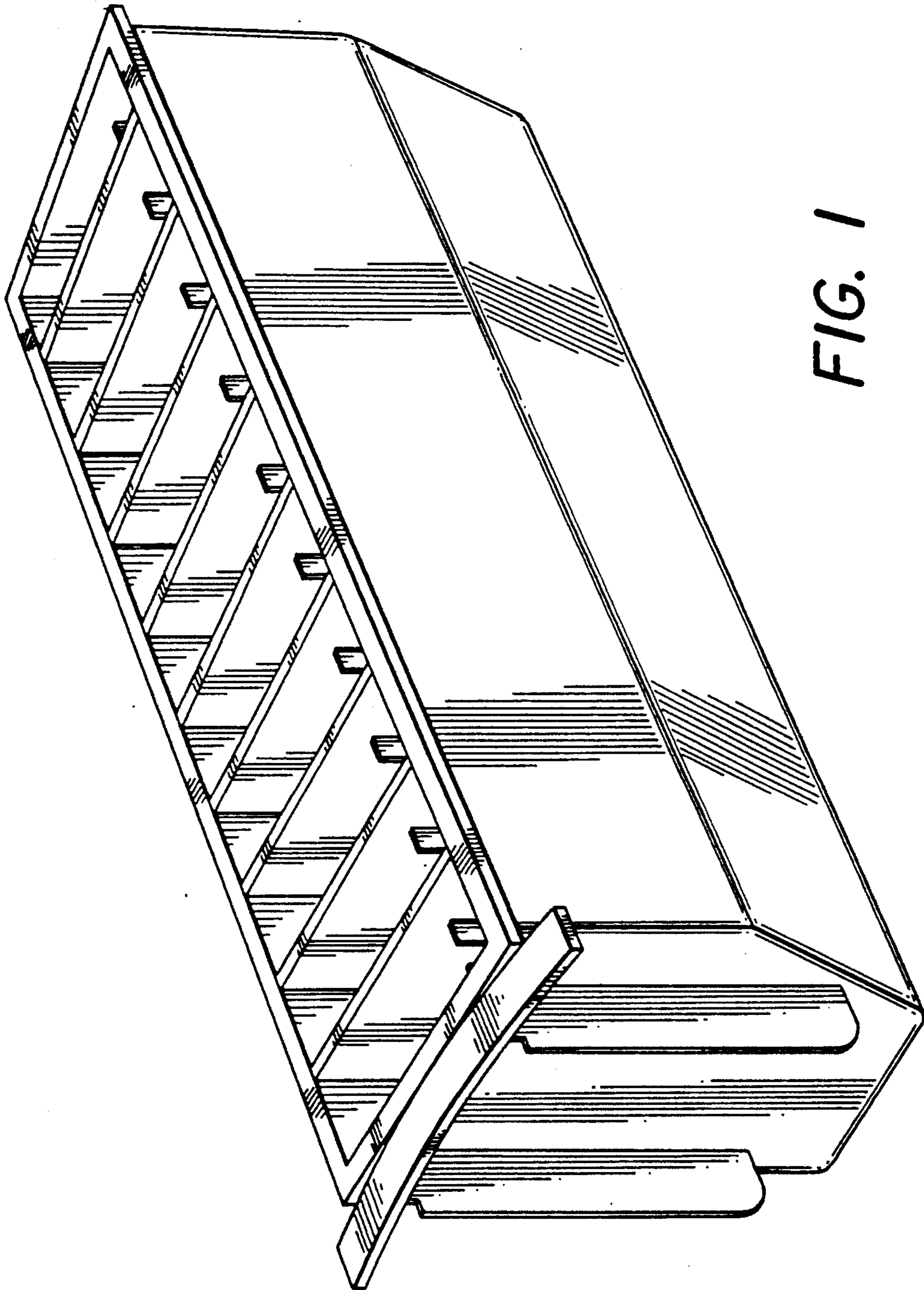

FIG. 1

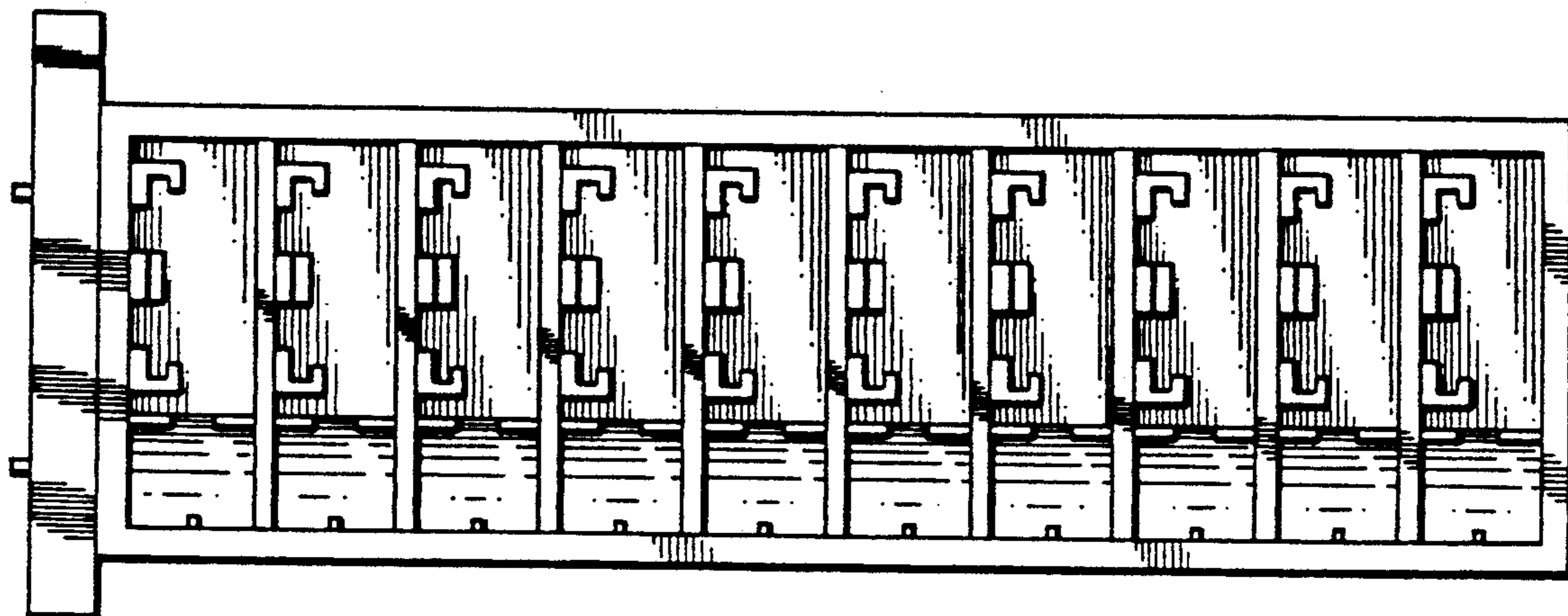

FIG. 2

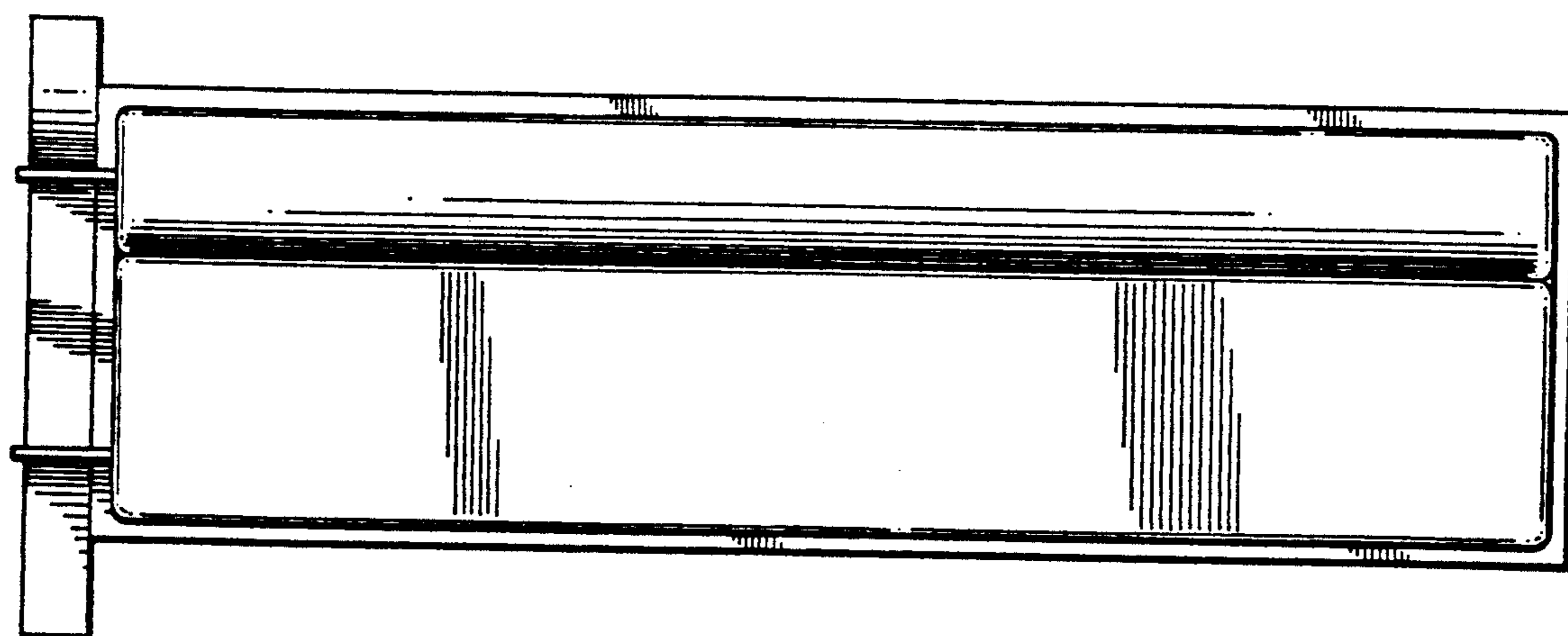
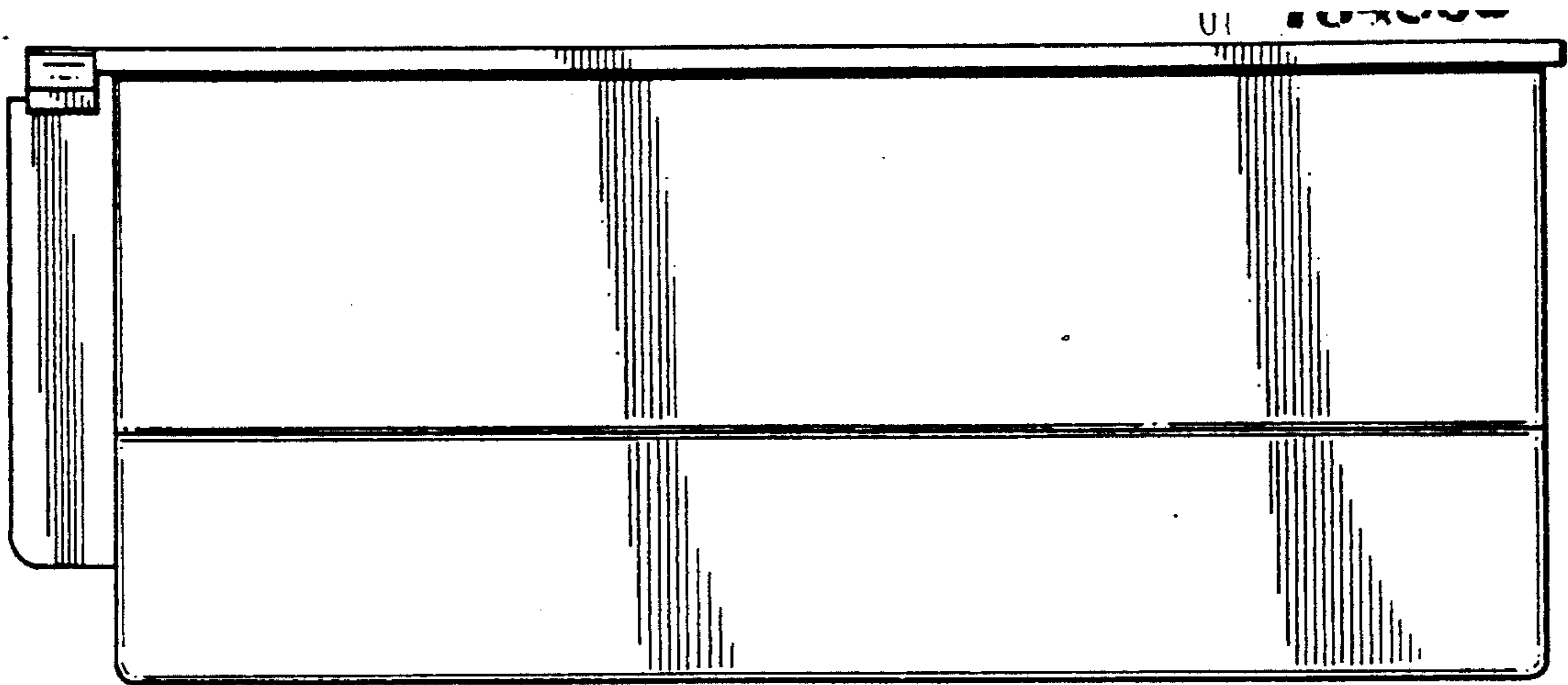
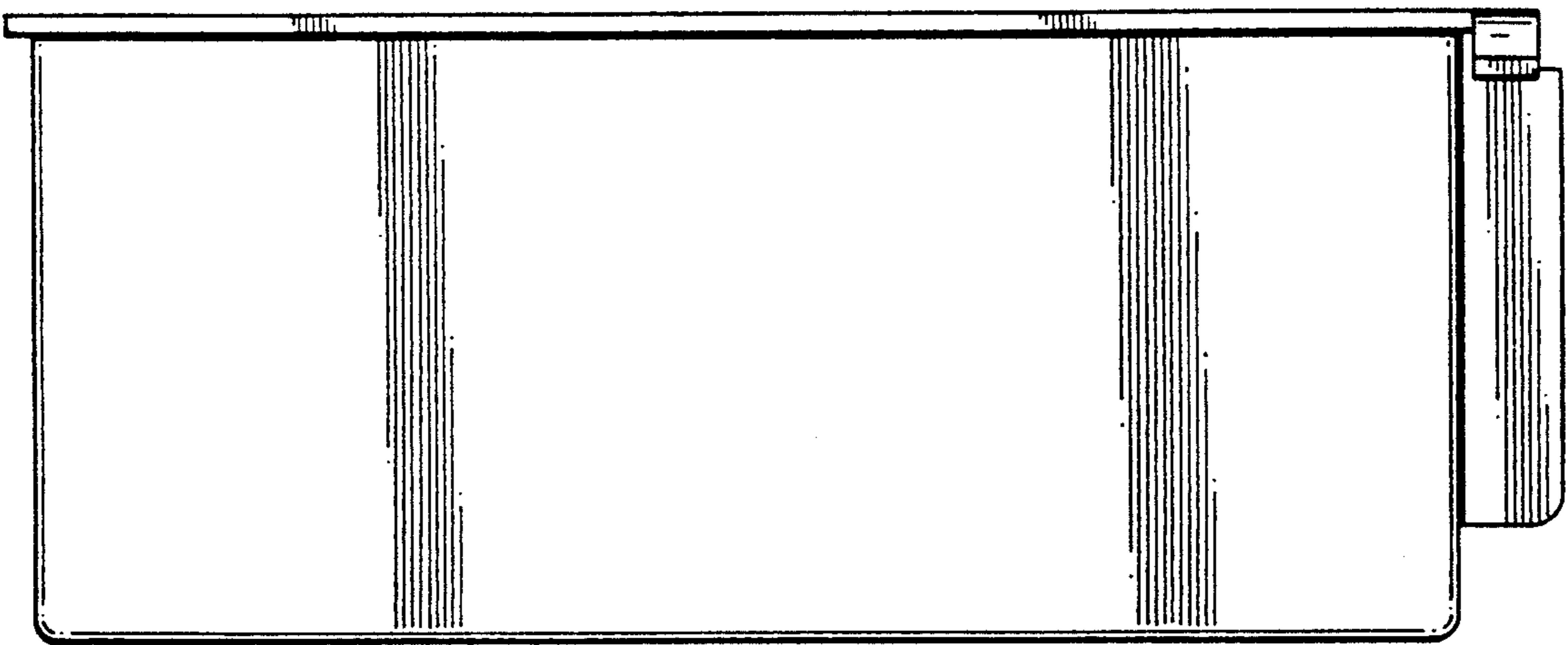

FIG. 3



*FIG. 4*



*FIG. 5*

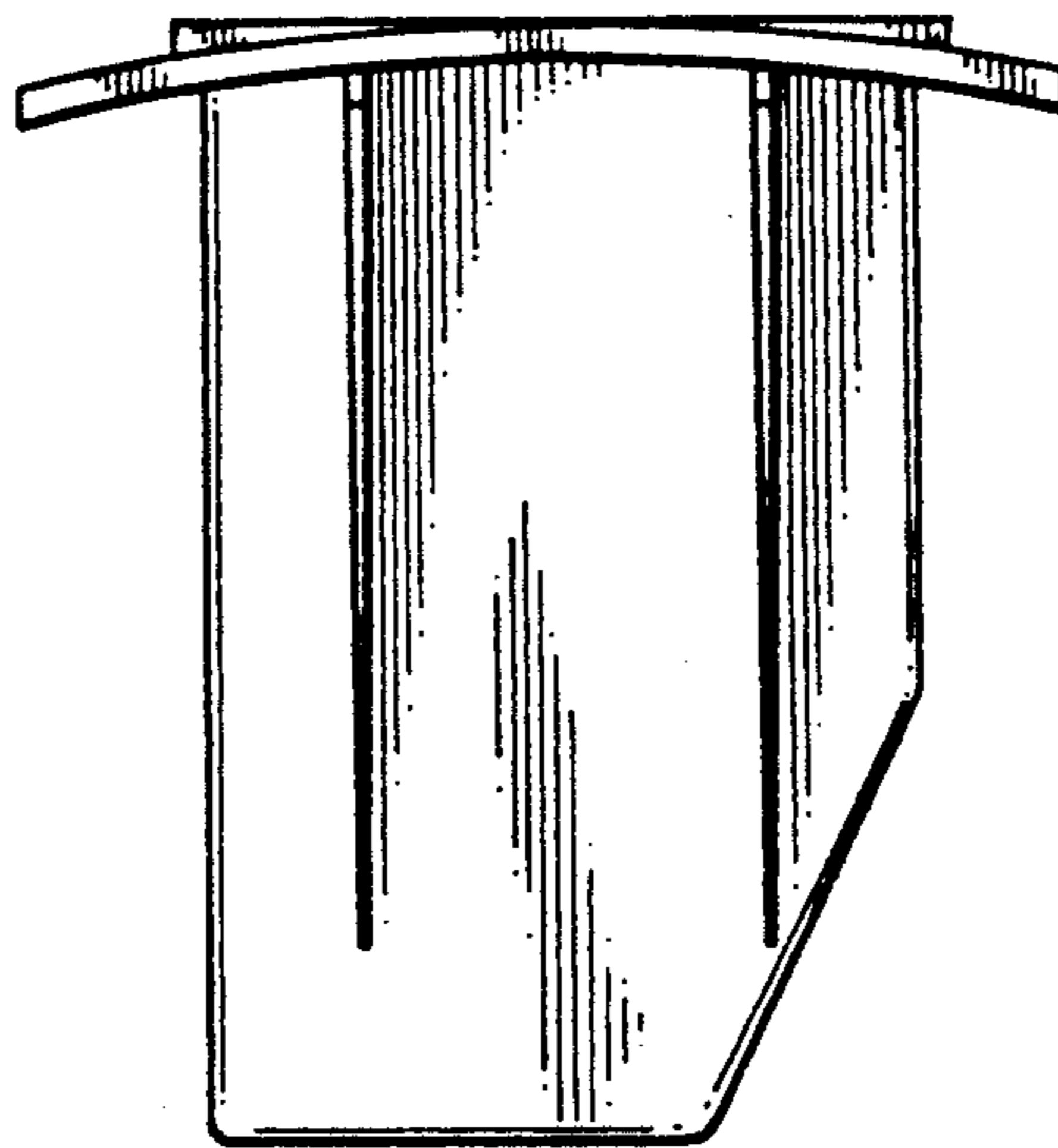

*FIG. 6*

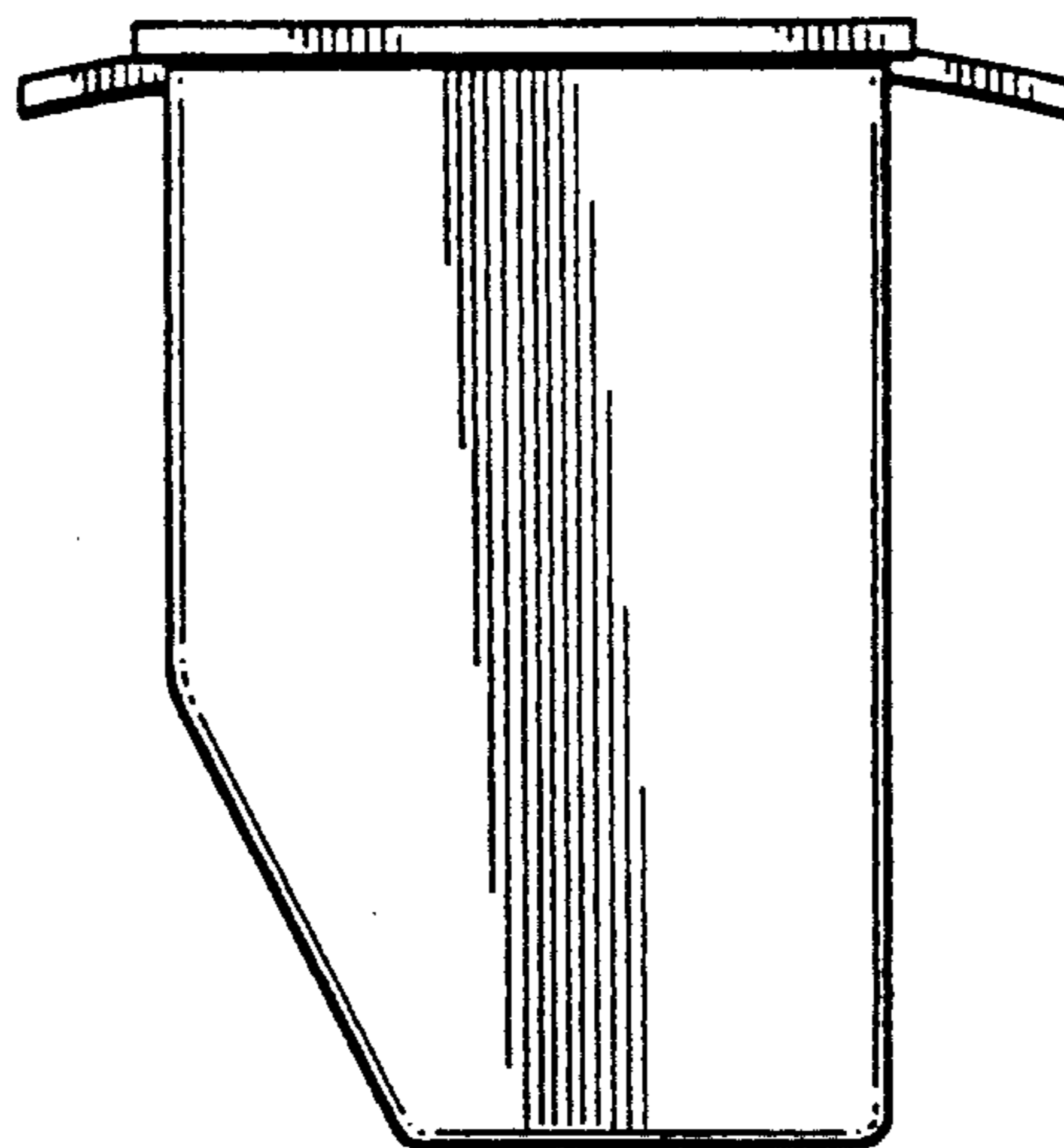

*FIG. 7*