



US00D335275S

United States Patent [19]

[11] Patent Number: **Des. 335,275**

Wright, Jr.

[45] Date of Patent: **** May 4, 1993**

[54] VEHICLE ATTACHED BOAT RACK

[76] Inventor: **James H. Wright, Jr.**, 5862 Sherrie La., Powder Springs, Ga. 30073

[**] Term: **14 Years**

[21] Appl. No.: **659,041**

[22] Filed: **Feb. 22, 1991**

[52] U.S. Cl. **D12/156**

[58] Field of Search **D12/156; 296/3; 224/42.45 R, 42.42 R**

[56] References Cited

U.S. PATENT DOCUMENTS

2,570,802	10/1951	Hatteburg	296/3
3,891,262	6/1975	Brunel	296/3
4,138,046	2/1979	DeFreze	296/3

Primary Examiner—James M. Gandy
Attorney, Agent, or Firm—Leon Gilden

[57] CLAIM

The ornamental design for a vehicle attached boat rack, as shown and described.

DESCRIPTION

FIG. 1 is a front elevational view of the vehicle attached boat rack showing my new design;
 FIG. 2 is a rear elevational view thereof;
 FIG. 3 is an enlarged left side elevational view thereof;
 FIG. 4 is an enlarged right side elevational view thereof;
 FIG. 5 is a slightly enlarged top plan view thereof;
 FIG. 6 is a slightly enlarged bottom plan view thereof;
 and,
 FIG. 7 is a perspective view thereof on a reduce scale.

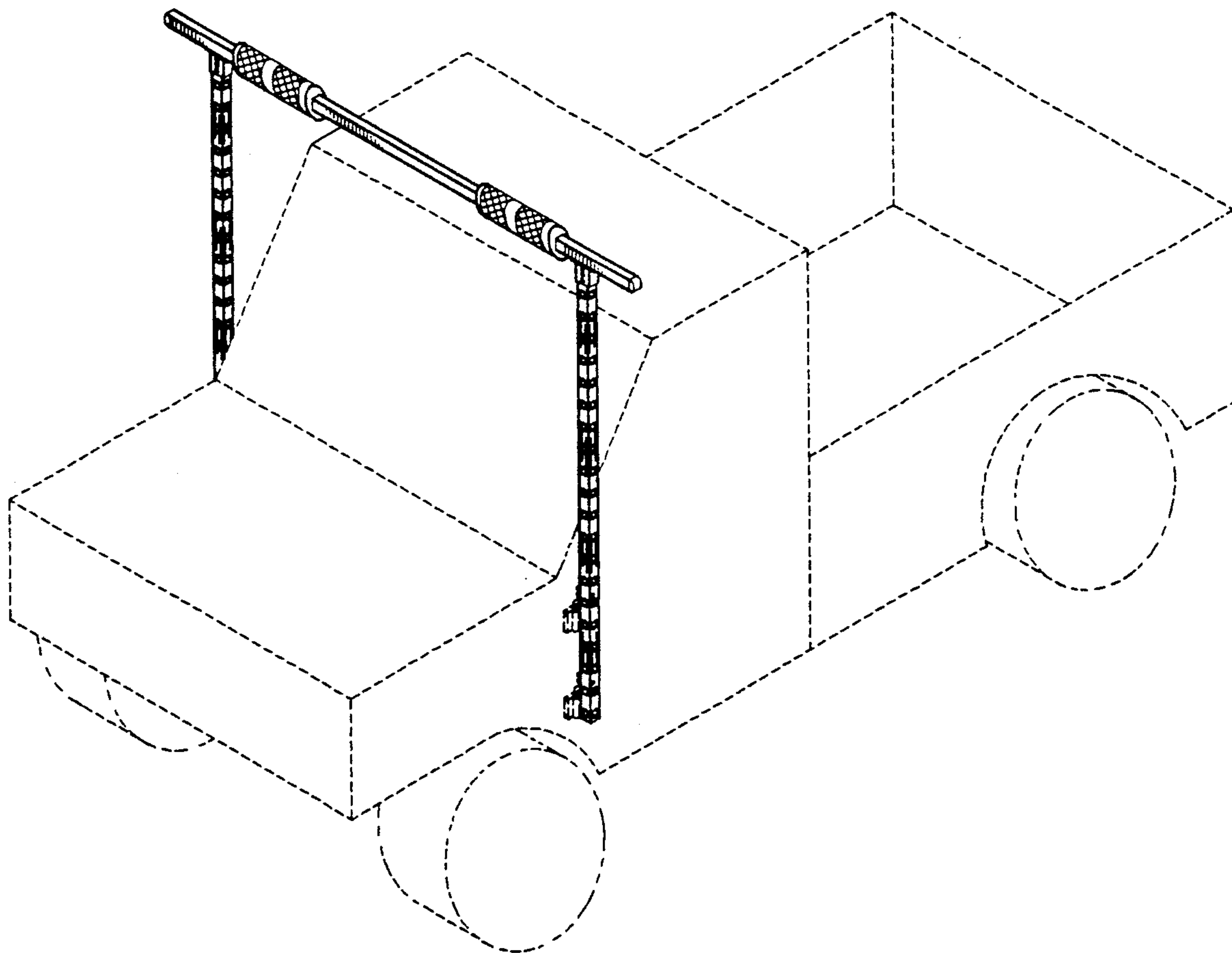

FIG. 1

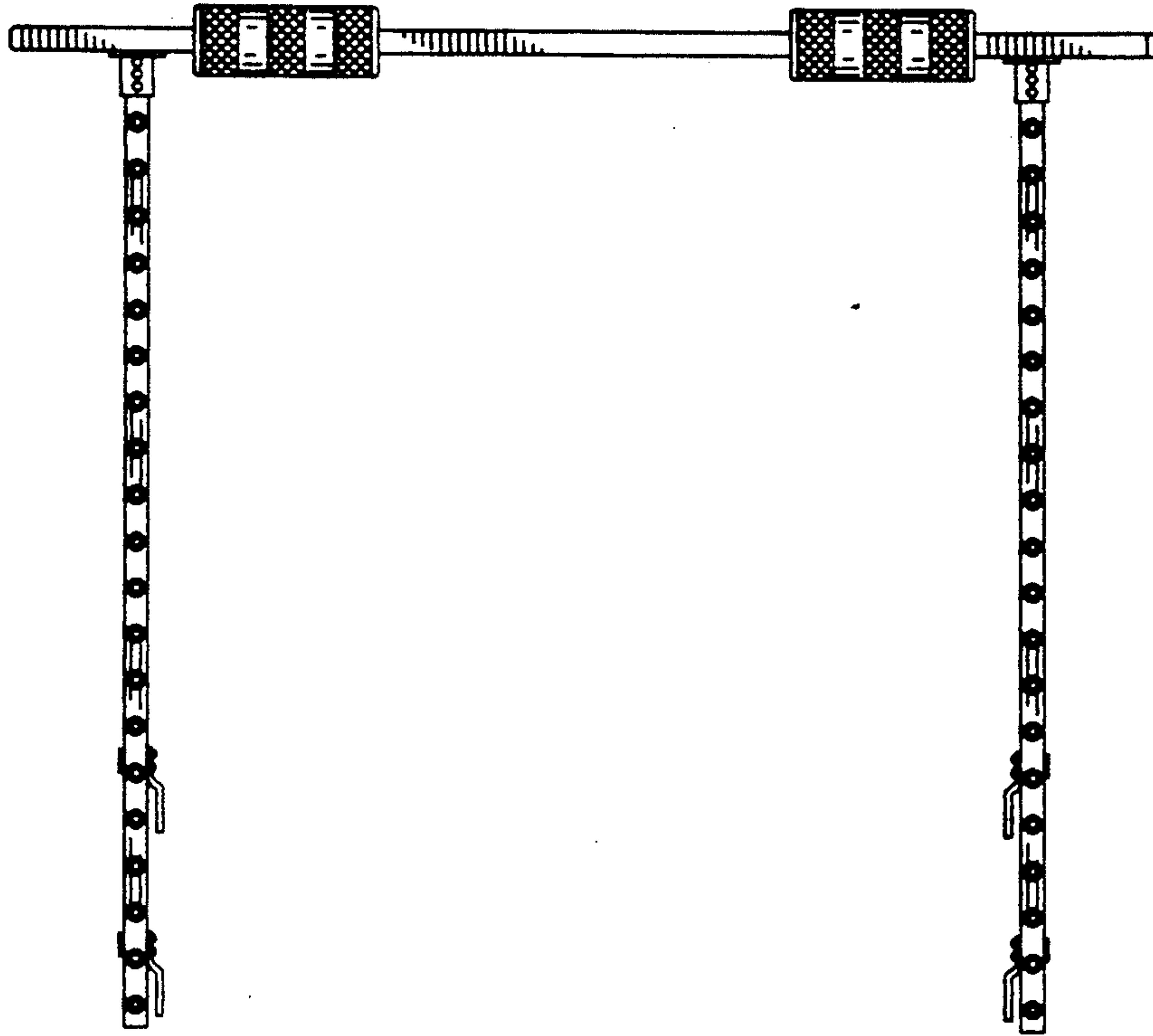

FIG. 2

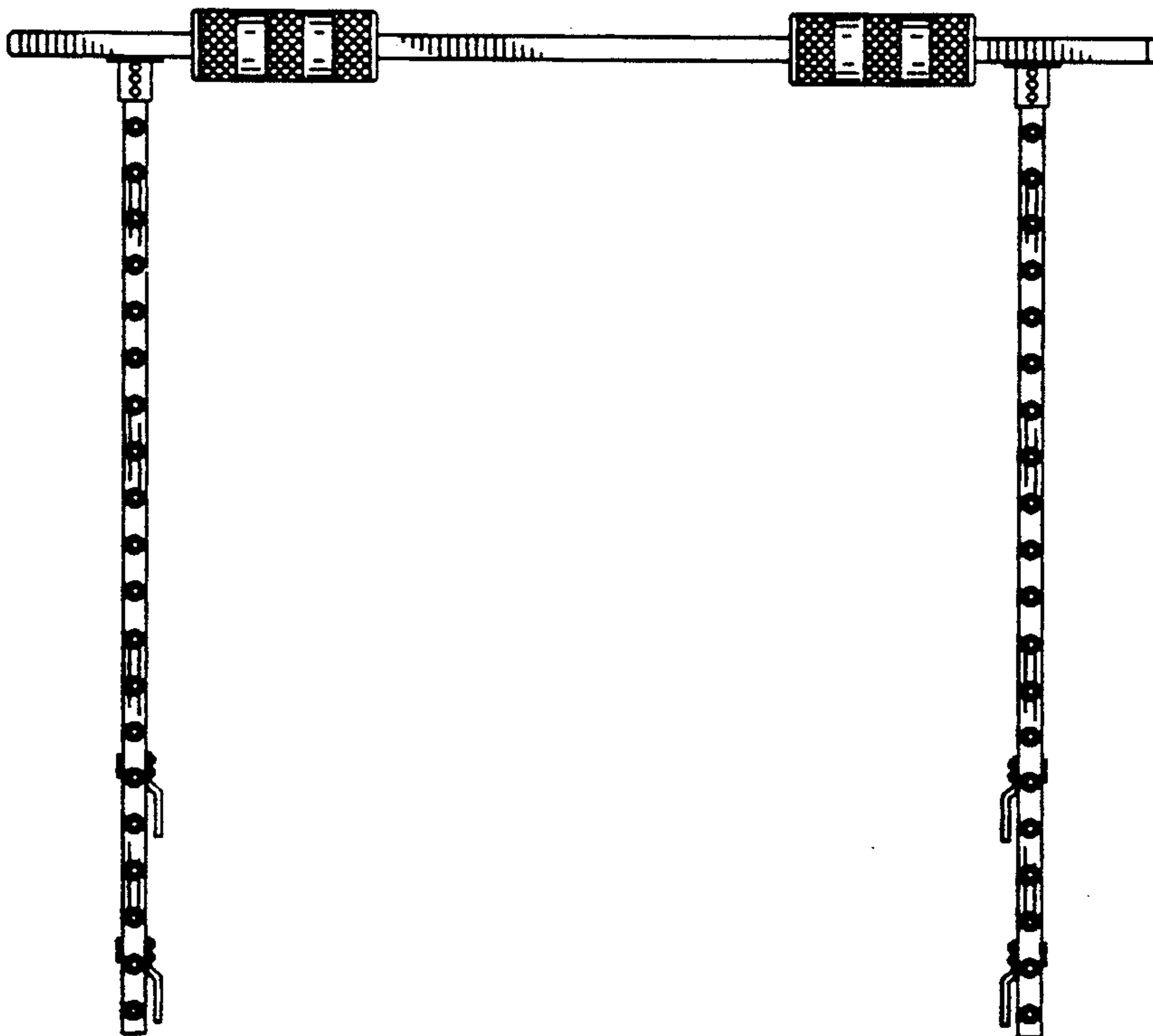

FIG. 3

FIG. 4

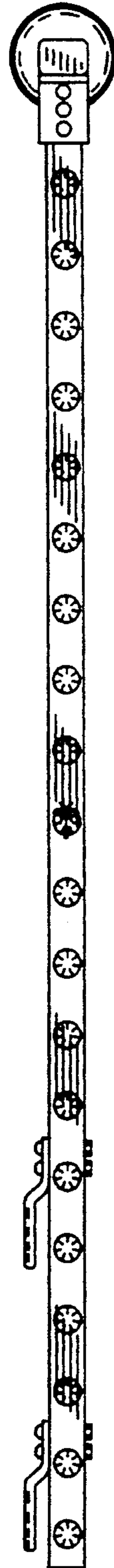
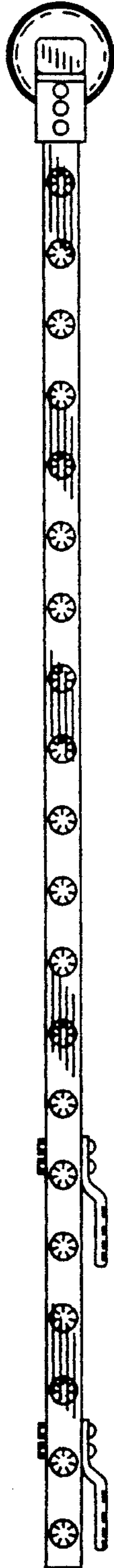

FIG. 5

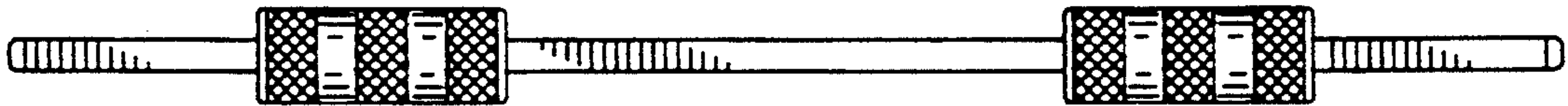

FIG. 6

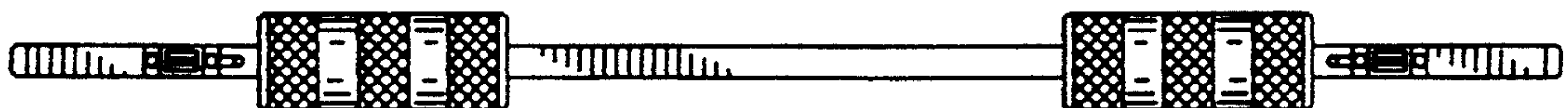

FIG. 7

