



US00D335254S

United States Patent [19]

[11] Patent Number: **Des. 335,254**

Carter

[45] Date of Patent: **** May 4, 1993**

[54] SAFETY FLAG MOUNTING BRACKET FOR USE WITH A RECREATIONAL VEHICLE

[76] Inventor: **William W. Carter**, Rte. 1 Box 42, Brundidge, Ala. 36010

[**] Term: **14 Years**

[21] Appl. No.: **736,829**

[22] Filed: **Jul. 29, 1991**

[52] U.S. Cl. **D8/354; D8/373; D8/380**

[58] Field of Search **D12/115; 248/61-65, 248/69, 74.1; D8/373, 354, 349, 394, 396, 380; 24/335, 329; 211/60.1**

[56] **References Cited**

U.S. PATENT DOCUMENTS

3,051,424	8/1962	Duhamel	248/62
3,162,112	12/1964	Wheeler	248/62 X
3,652,045	3/1972	Hirt	248/62
3,848,786	11/1974	Baxter	211/60.1 X
4,461,440	7/1984	Heath	248/62 X
4,479,625	10/1984	Martz	248/62 X

OTHER PUBLICATIONS

KMC Stampings Brochure, Aug. 1, 1982, p. 48, hole piercing tool, item G circled at top of page.

Zierick catalog, 1986, p. 69, cable clamp, item 116 located at bottom left corner of page.

Primary Examiner—Wallace R. Burke
Assistant Examiner—H. Baynham
Attorney, Agent, or Firm—Veal & Associates

[57] **CLAIM**

The ornamental design for a safety flag mounting bracket for use with a recreational vehicle, as shown and described.

DESCRIPTION

FIG. 1 is a front perspective view of a safety flag mounting bracket for use with a recreational vehicle showing my new design;
FIG. 2 is a rear perspective view thereof;
FIG. 3 is a front elevational view thereof;
FIG. 4 is a rear elevational view thereof;
FIG. 5 is left side elevational view thereof;
FIG. 6 is a right side elevational view thereof;
FIG. 7 is a top plan view thereof;
FIG. 8 is a bottom view thereof; and,
FIG. 9 is a reduced scale perspective view showing the article in use.

The broken line showing of a structural member and a flag staff is for illustrative purposes only and forms no part of the claimed design.

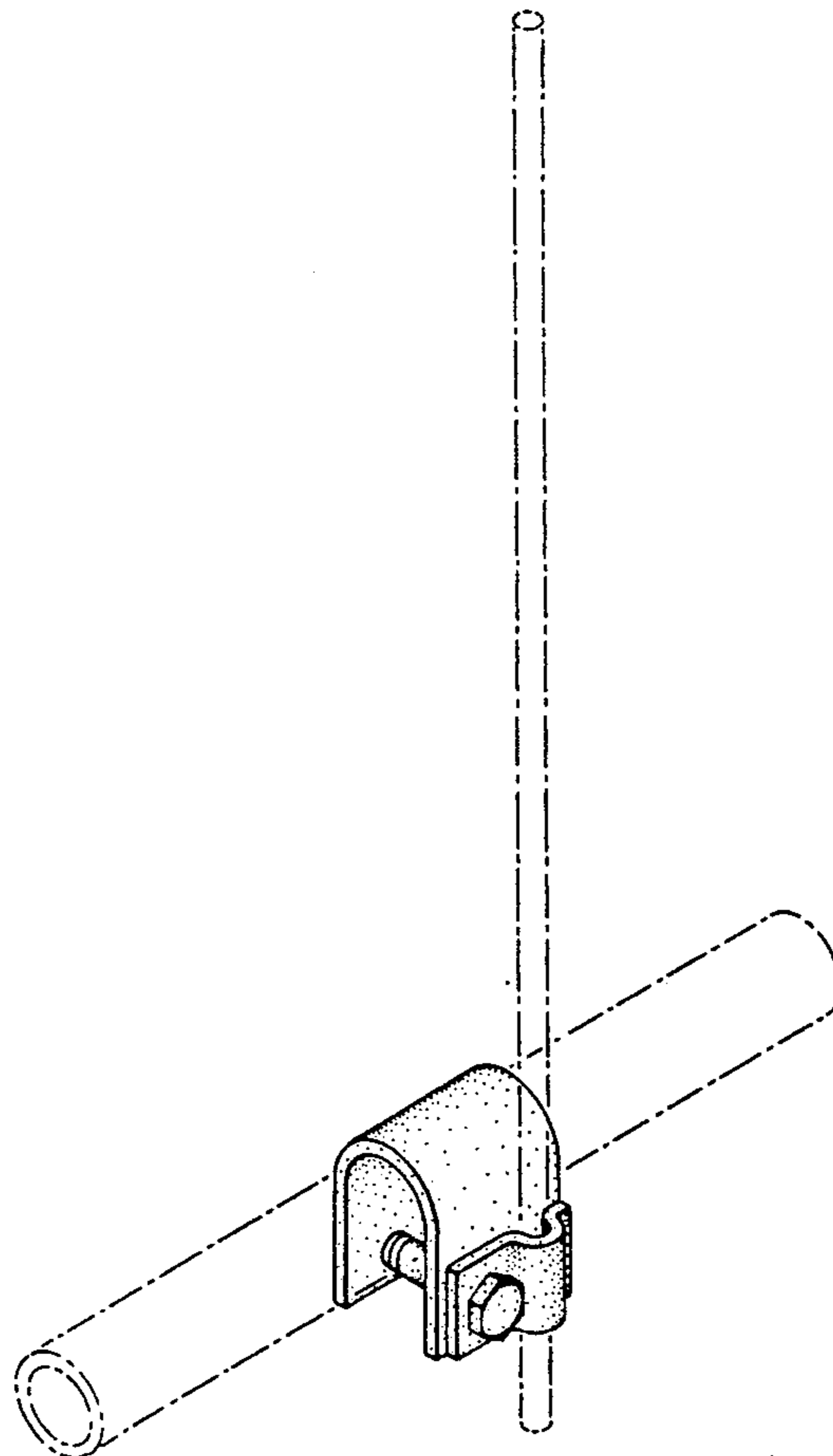

FIG. 1

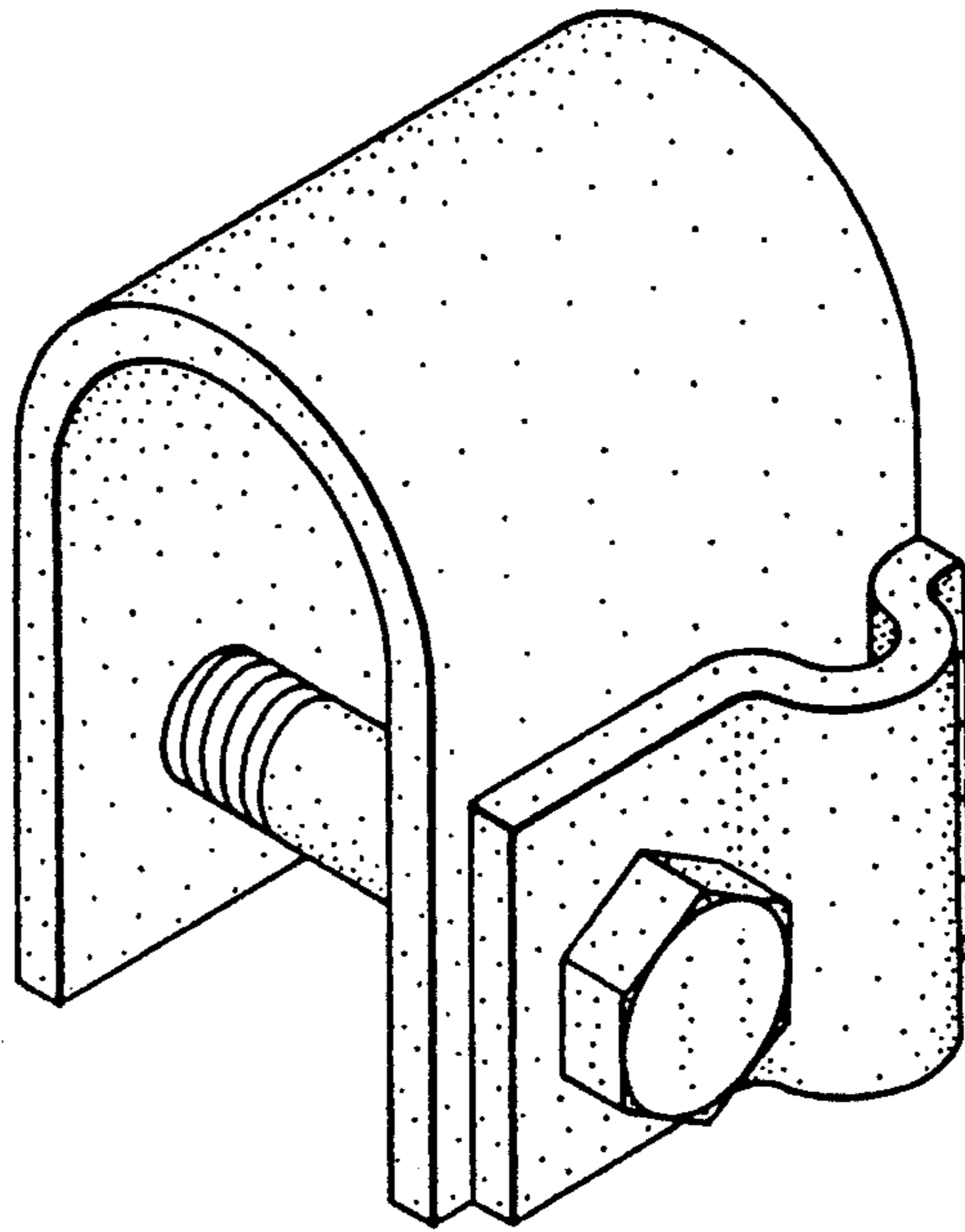

FIG. 2

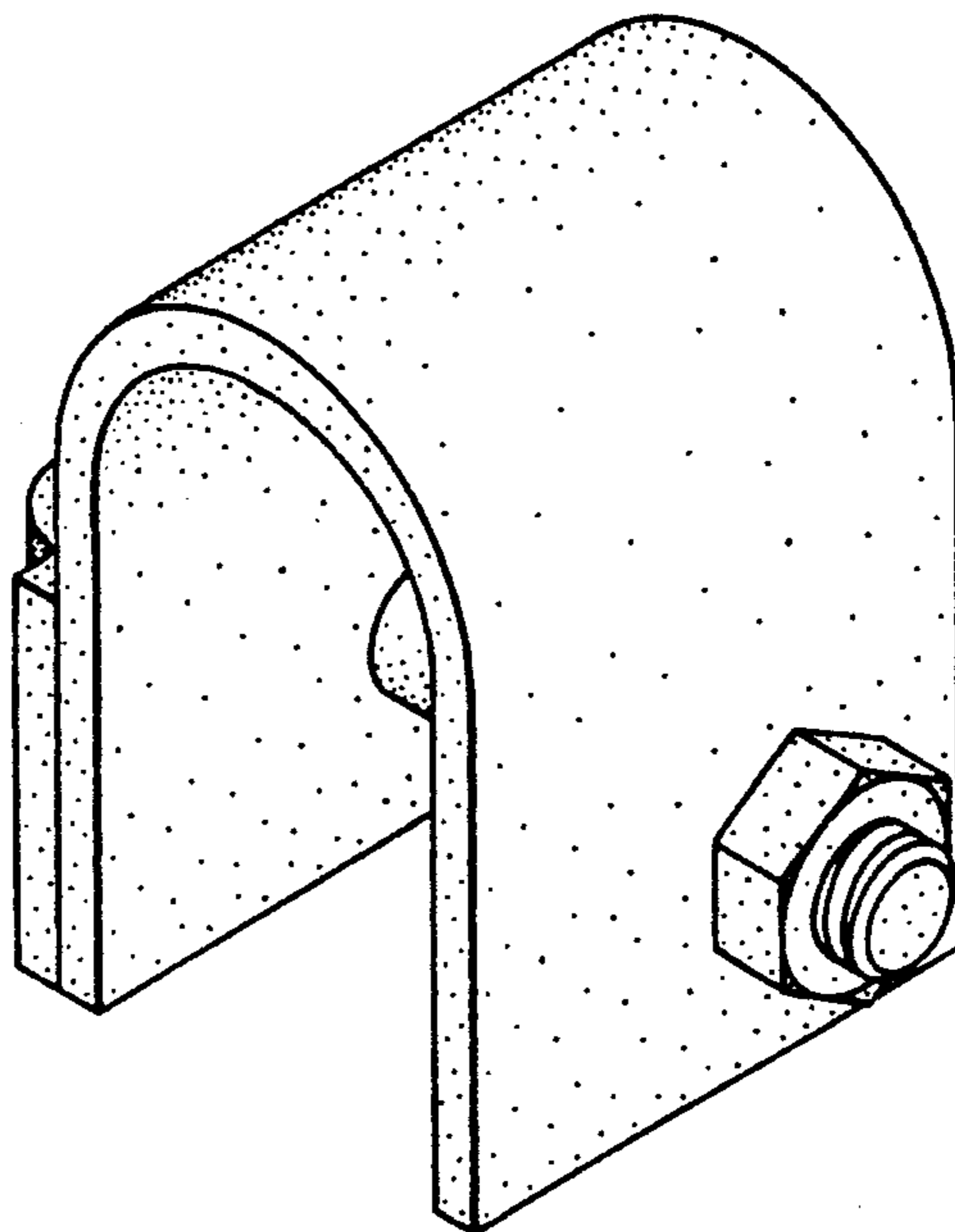

FIG. 3

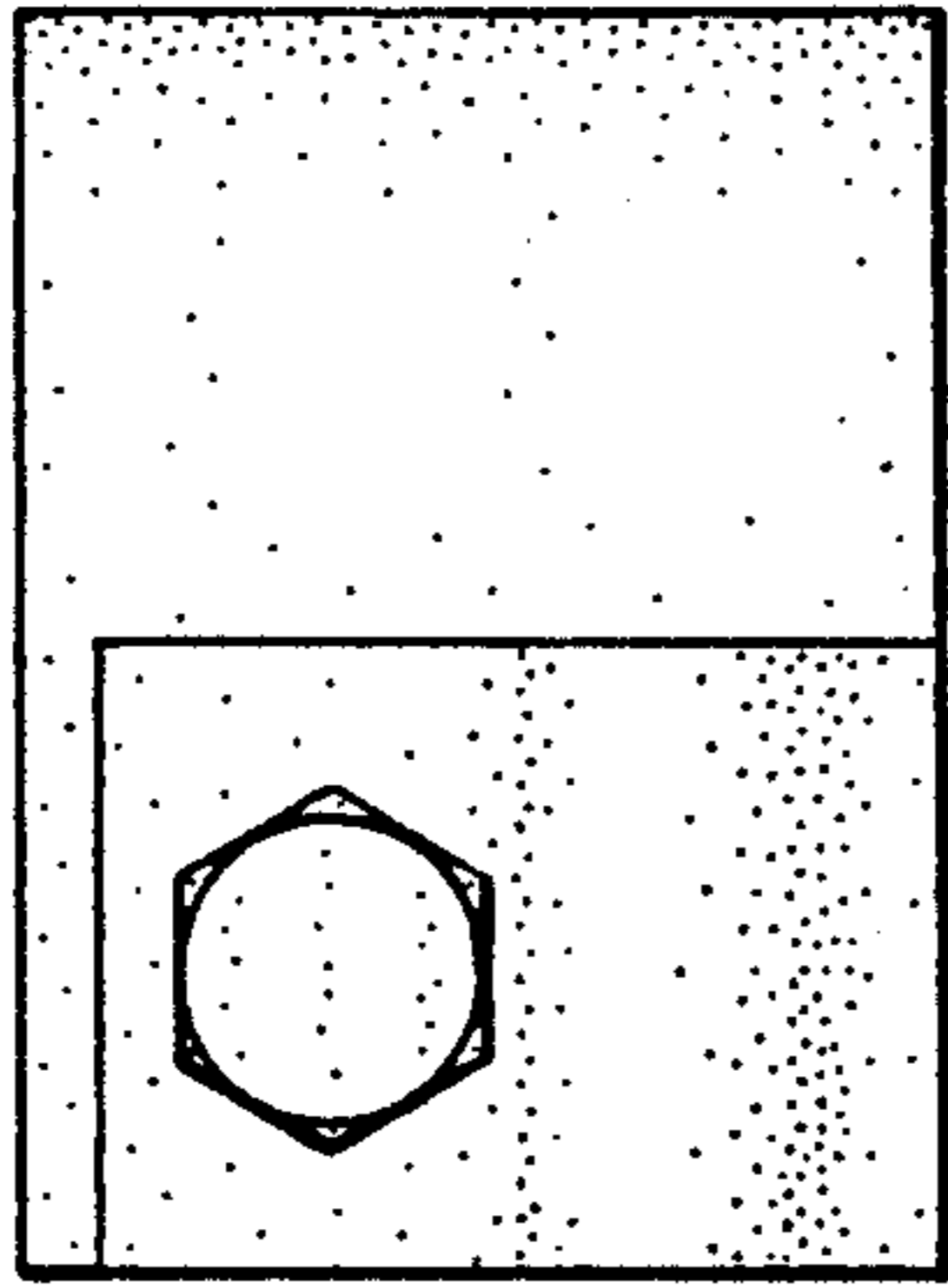

FIG. 4

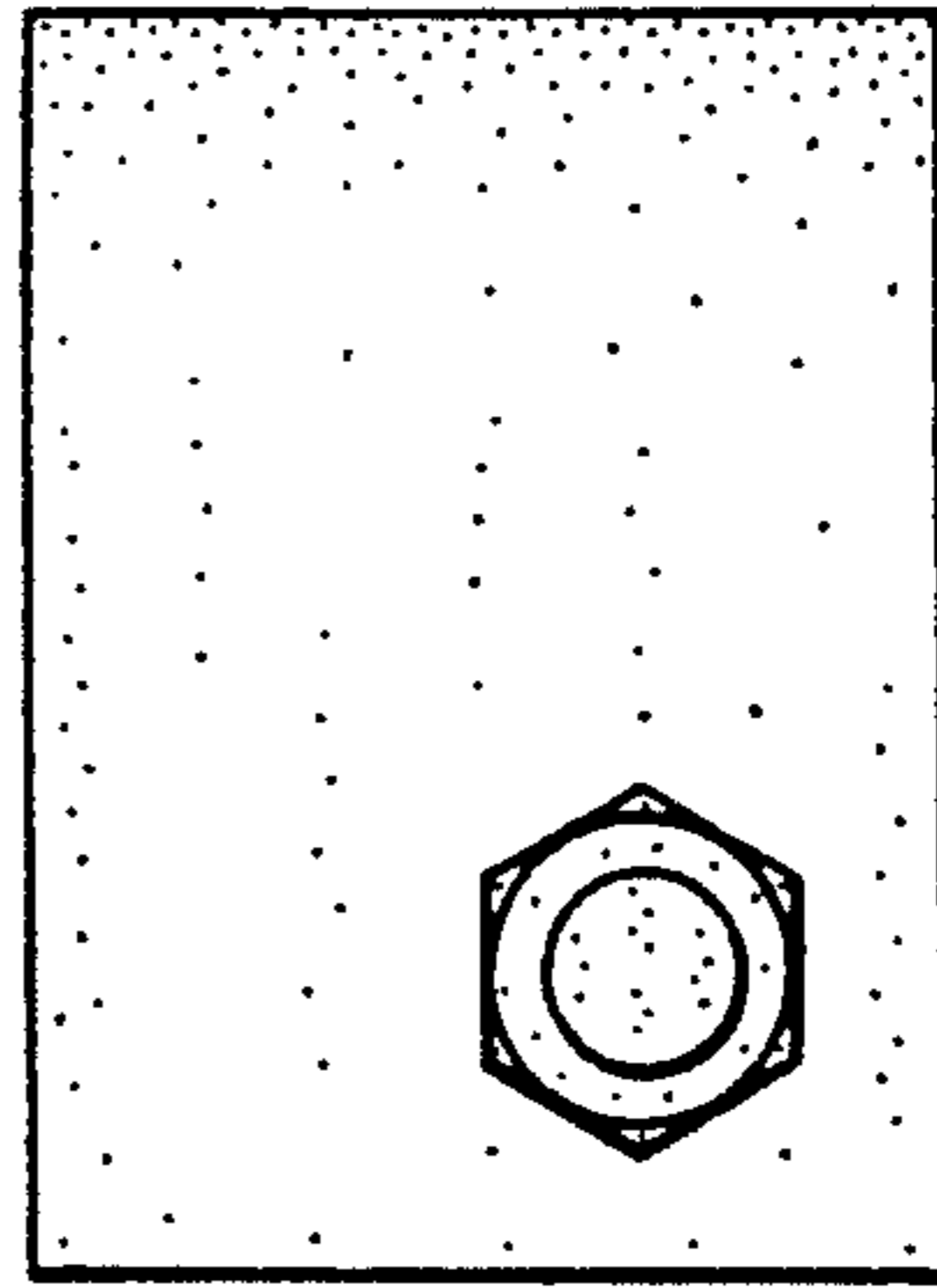

FIG. 5

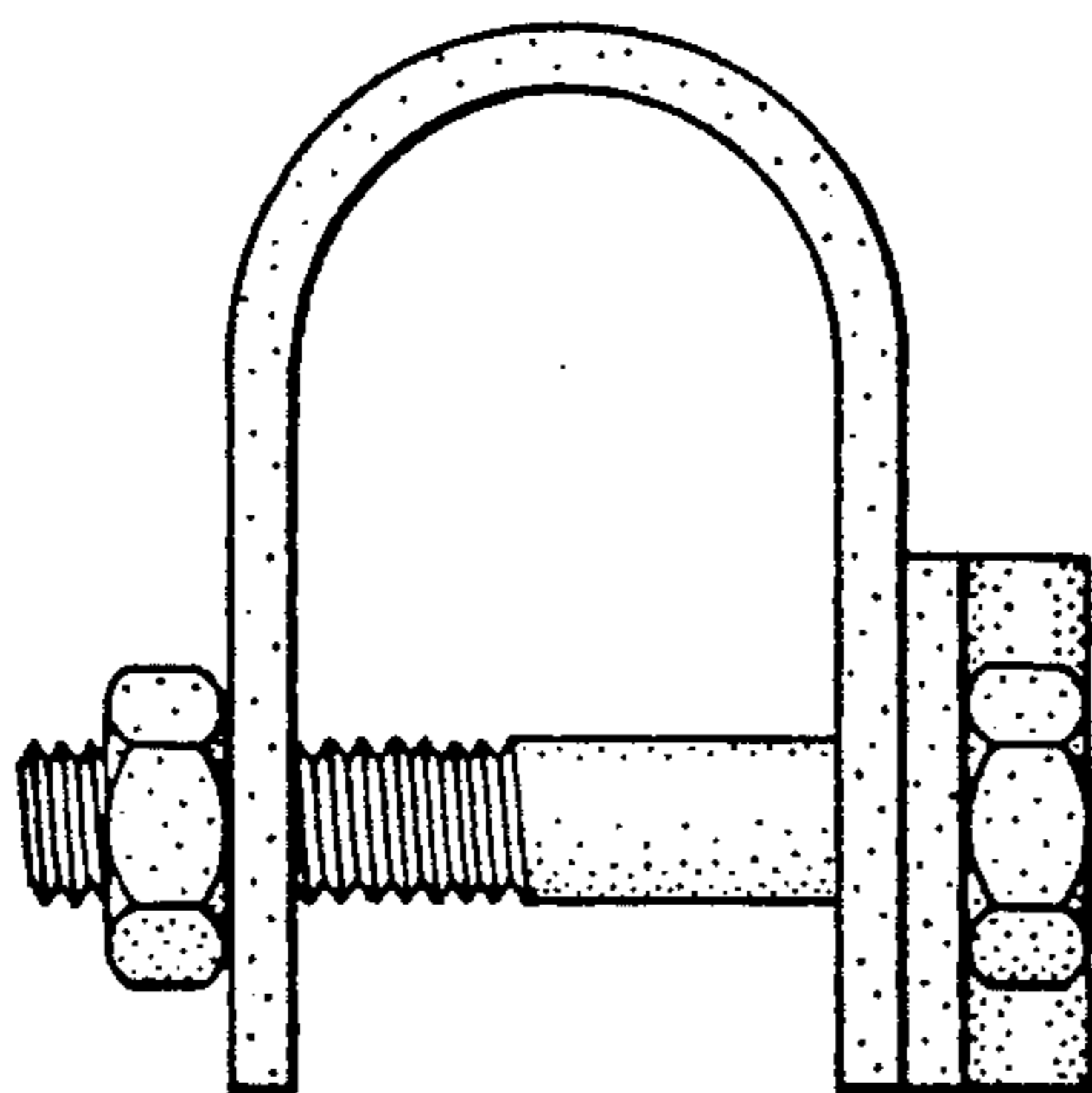

FIG. 6

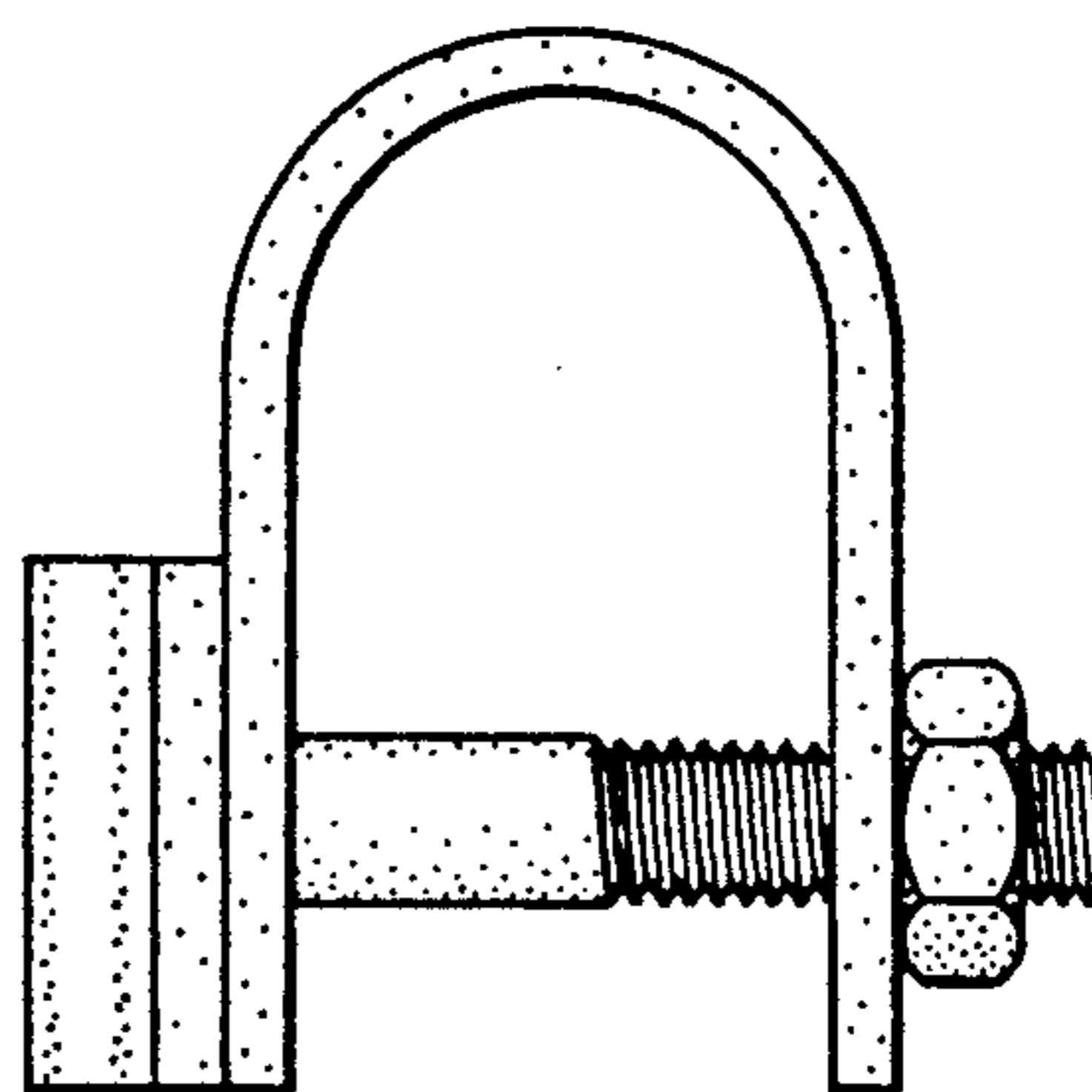

FIG. 7

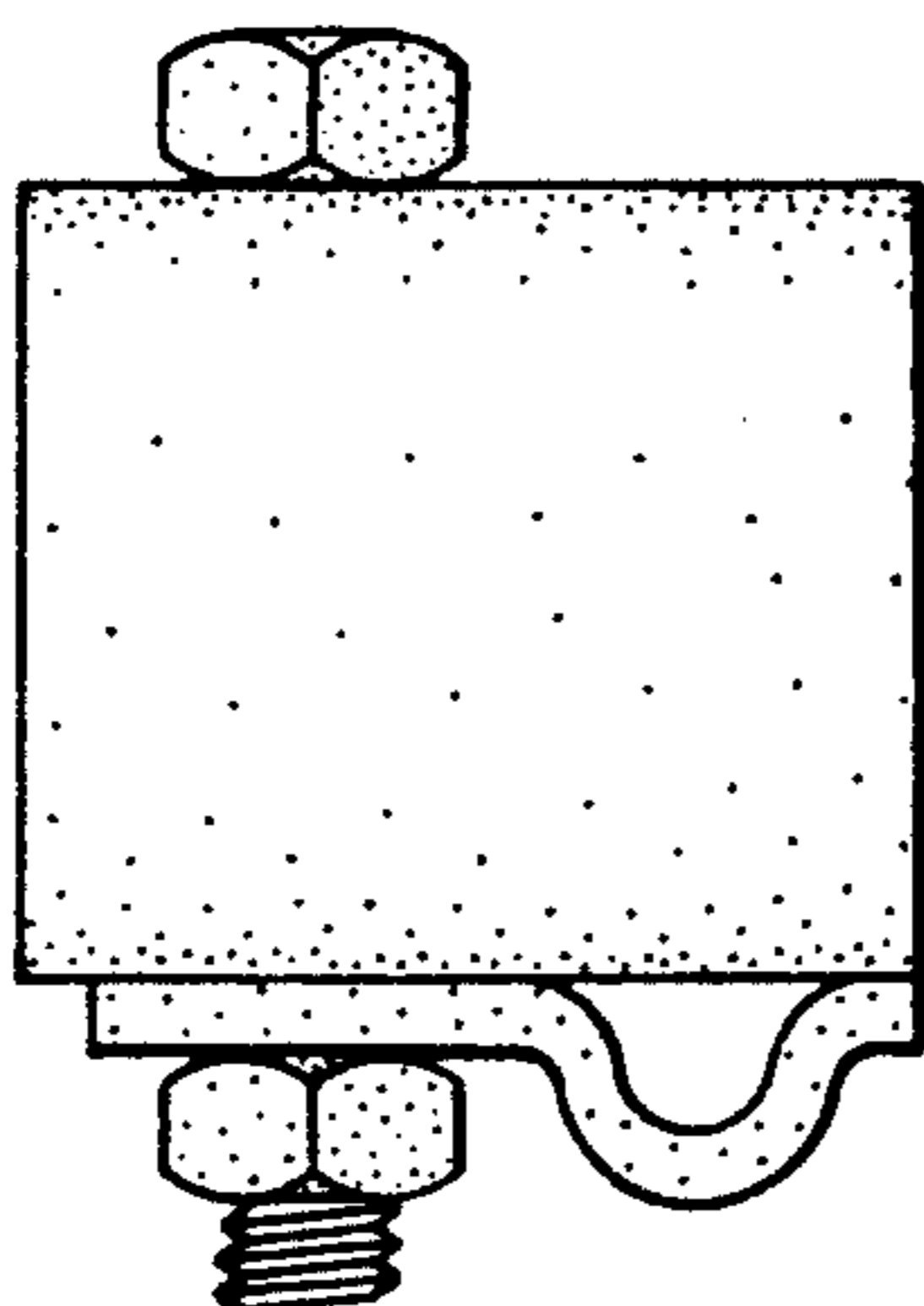

FIG. 8

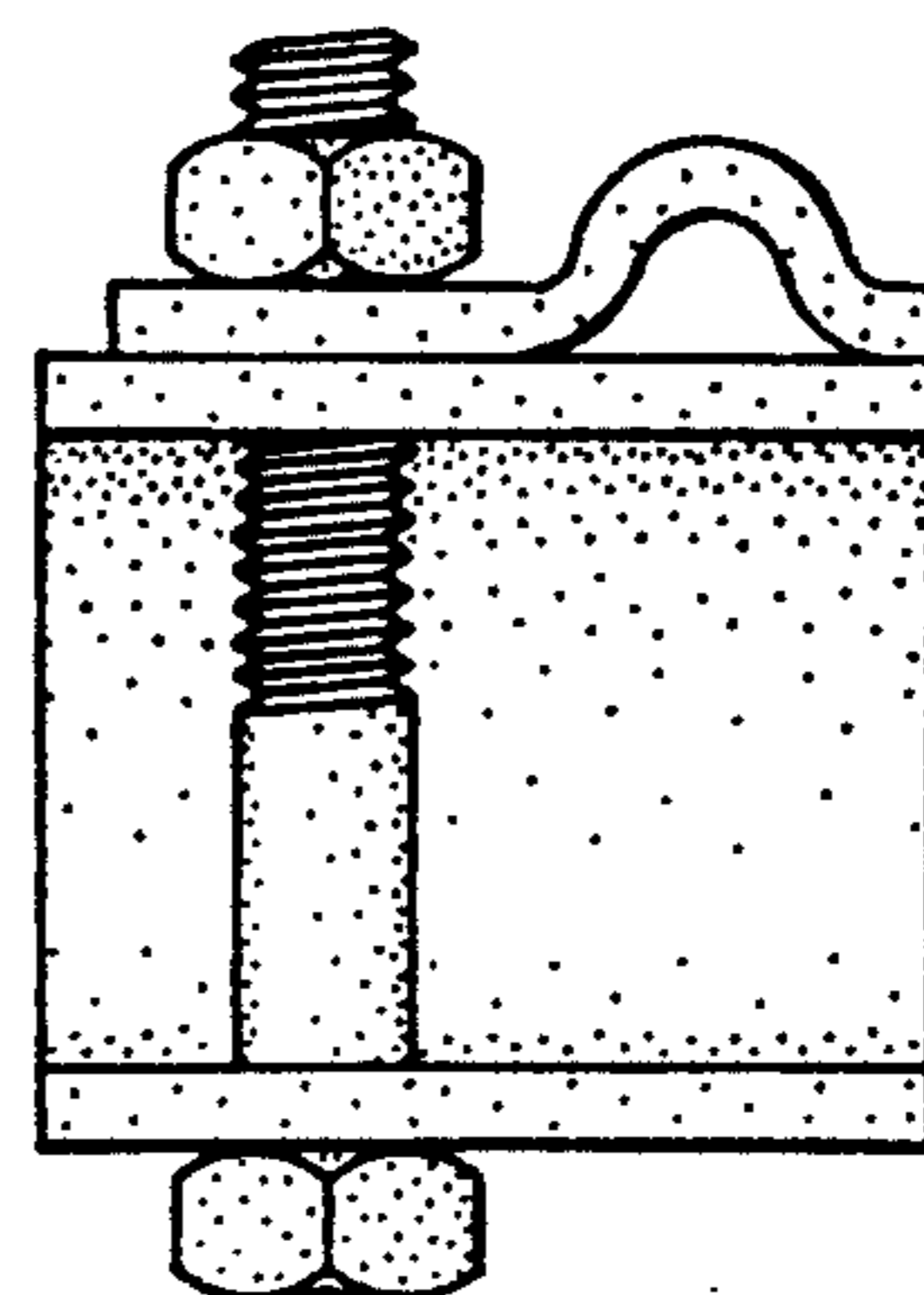

FIG. 9

