



US00D335118S

# United States Patent [19]

[11] Patent Number: **Des. 335,118**

Alexander

[45] Date of Patent: **\*\* Apr. 27, 1993**

[54] POWER BOAT

[75] Inventor: **John E. Alexander, Monroeville, Ind.**

[73] Assignee: **Porter, Inc., Decatur, Ind.**

[\*\*] Term: **14 Years**

[21] Appl. No.: **663,658**

[22] Filed: **Mar. 4, 1991**

[52] U.S. Cl. .... **D12/314**

[58] Field of Search ..... **D12/300, 310-314, D12/318; 114/56, 355, 288-291**

[56] **References Cited**

**PUBLICATIONS**

Boating, Jul. 1983, p. 68, Wellcraft's "Scarab III".  
Excalibur Marine Inc. brochure 1980 ©, "Excalibur 27".

The Sharper Image Cat. Feb. 1986, Cigarette Cafe Racer TM.

*Primary Examiner*—Kay H. Chin  
*Attorney, Agent, or Firm*—Pearne, Gordon, McCoy & Granger

[57] **CLAIM**

The ornamental design for a power boat, as shown and described.

**DESCRIPTION**

FIG. 1 is a perspective view from below of a power boat, showing my new design;  
FIG. 2 is a side elevational view thereof, the opposite side elevation being a mirror image of that shown;  
FIG. 3 is a top plan view thereof;  
FIG. 4 is a bottom plan view thereof;  
FIG. 5 is a front elevational view thereof;  
FIG. 6 is a rear elevational view thereof; and,  
FIG. 7 is a top and rear perspective view thereof.

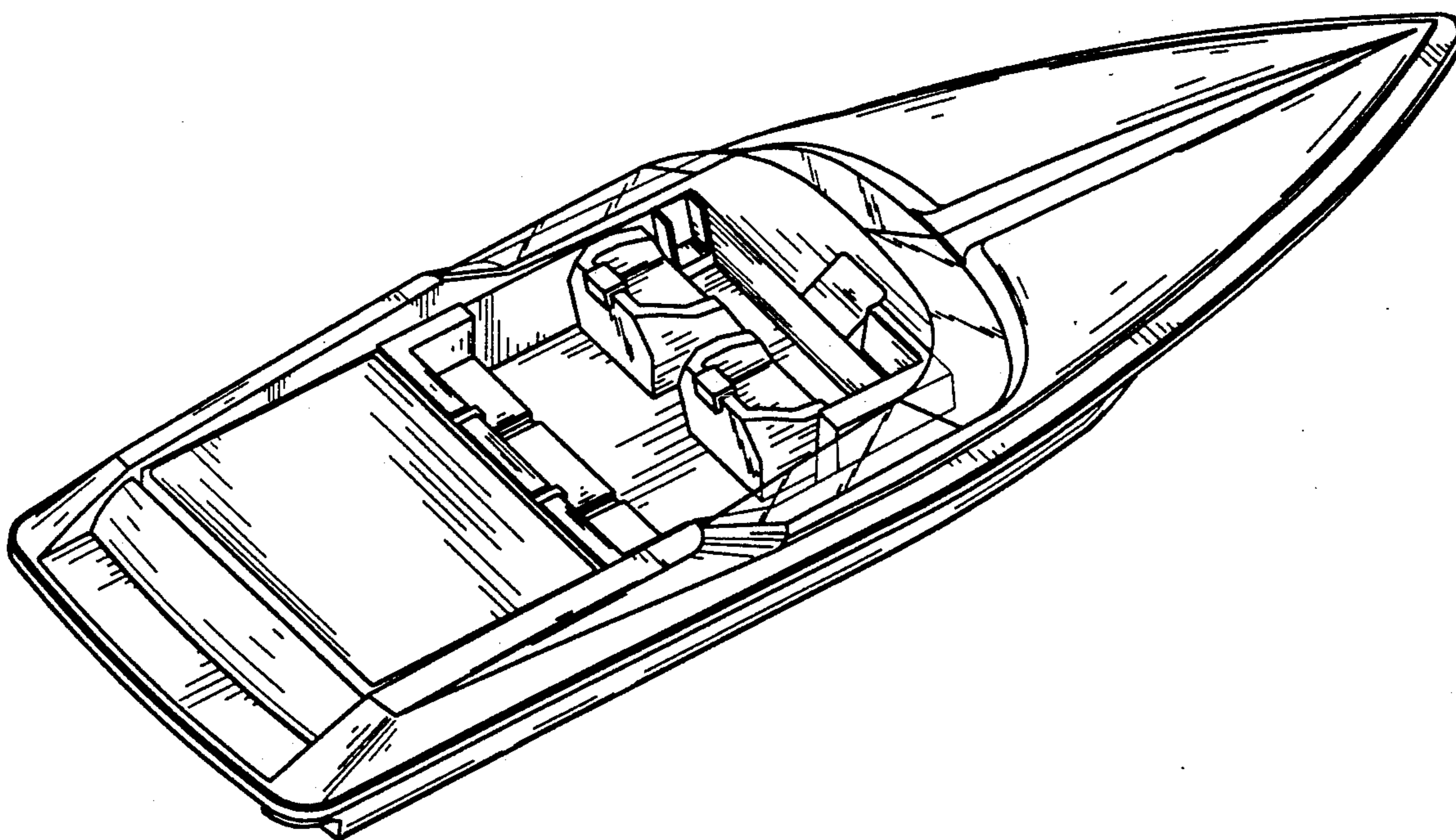



Fig. 1



Fig. 2

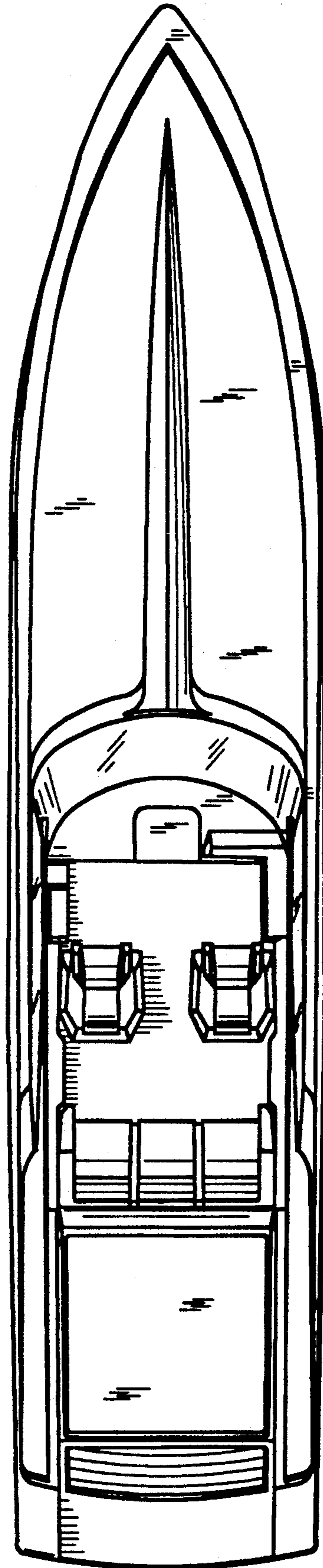

Fig. 3

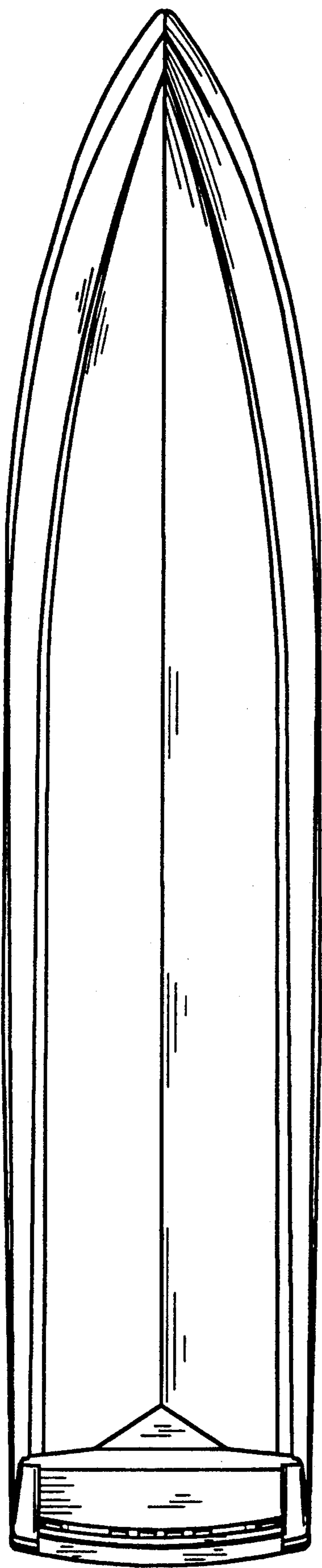

Fig. 4

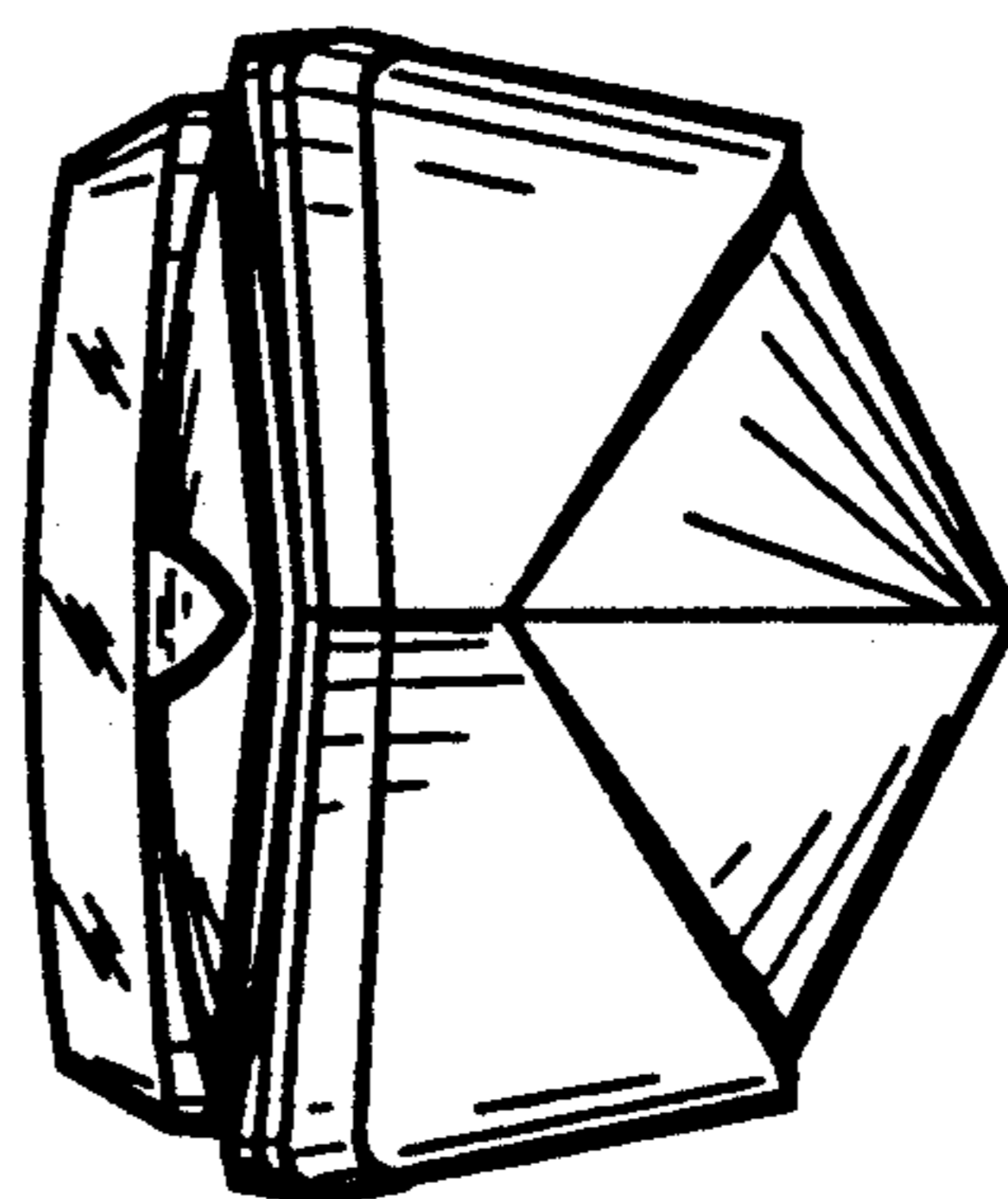

Fig. 5

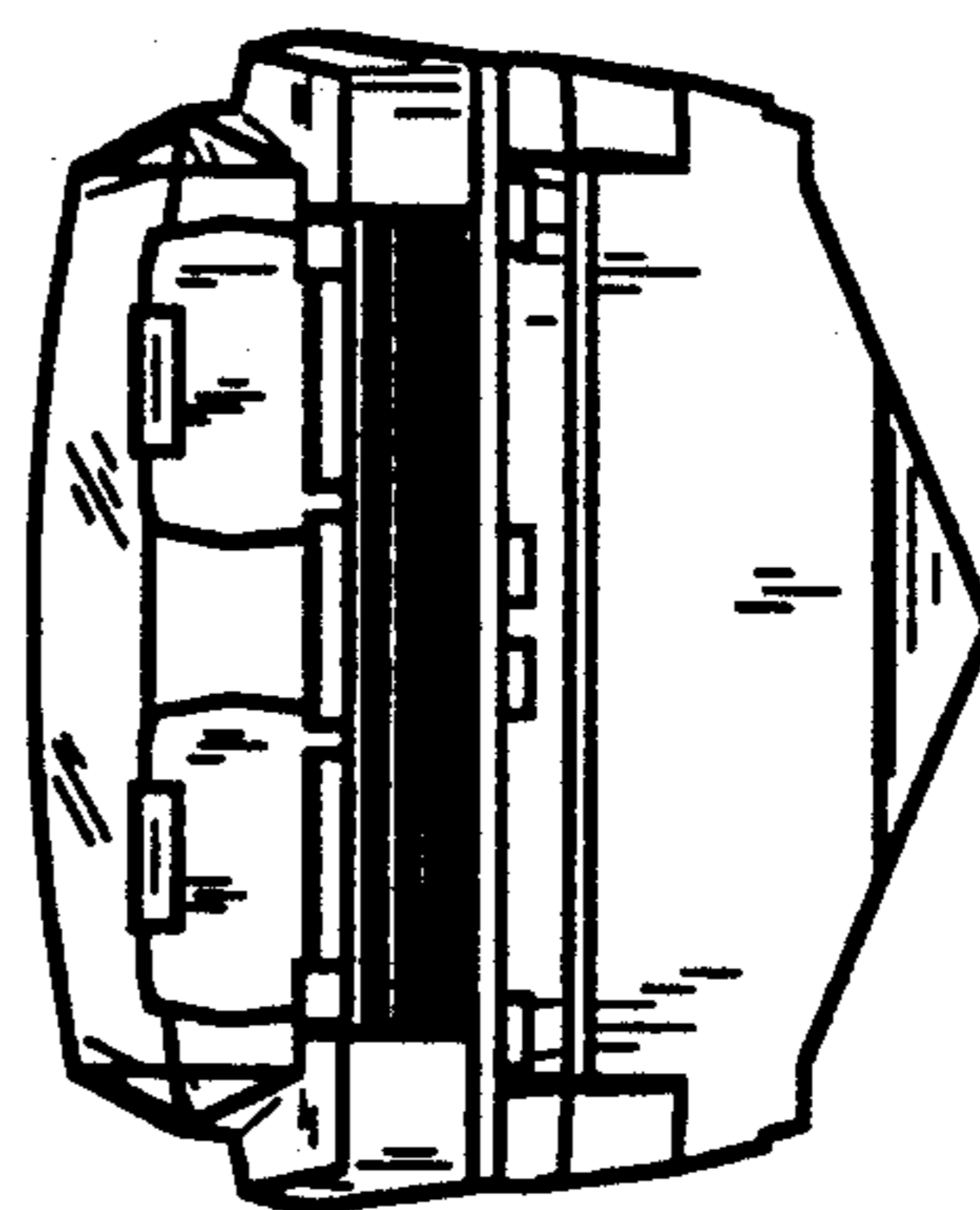

Fig. 6

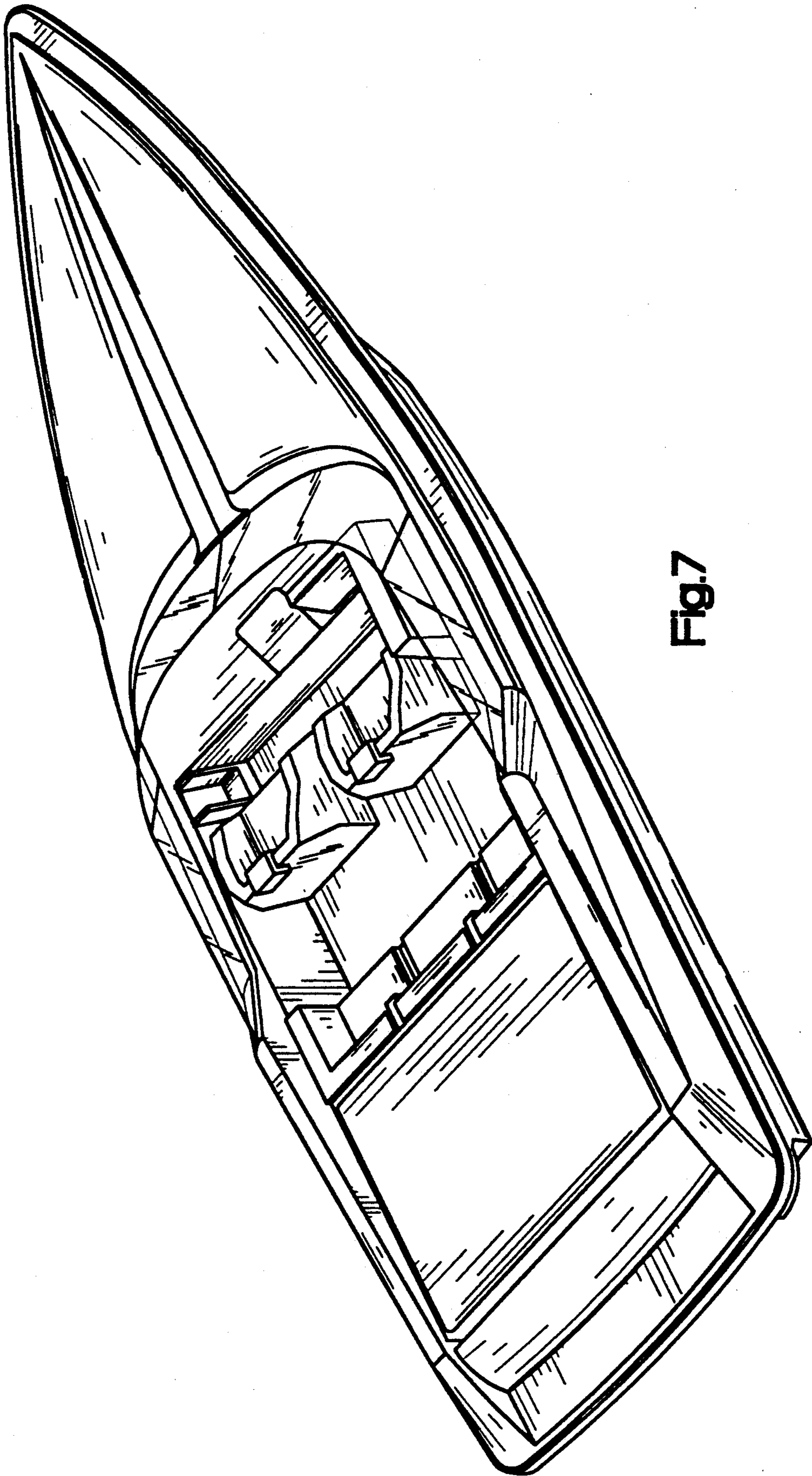

Fig. 7