



US00D335116S

United States Patent [19]

[11] Patent Number: **Des. 335,116**

Reed et al.

[45] Date of Patent: **** Apr. 27, 1993**

[54] **CARGO BOX FOR ATTACHMENT TO THE REAR WINDOW OF TRUCKS**

D. 300,735 4/1989 Thomas D12/156
3,833,253 9/1974 Butler 296/99.1

[75] Inventors: **Floyd W. Reed**, P.O. Box 36,
Rochford, S. Dak. 57778; **Arlen L. Huff**, South Bend, Ind.

Primary Examiner—James M. Gandy
Attorney, Agent, or Firm—Peterson, Wicks, Nemer & Kamrath

[73] Assignee: **Floyd W. Reed**, Rochford, S. Dak.

[57] **CLAIM**

[**] Term: **14 Years**

The ornamental design for cargo box for attachment to the rear window of trucks, as shown and described.

[21] Appl. No.: **801,970**

DESCRIPTION

[22] Filed: **Dec. 3, 1991**

[52] U.S. Cl. **D12/157; D12/156**

[58] Field of Search **D12/156, 157; 296/10, 296/26, 99.1, 100, 102, 164; 224/42.42**

FIG. 1 is a perspective view of a cargo box for attachment to the rear windows of trucks embodying our new design;

FIG. 2 is a top plan view;

FIG. 3 is a rear elevational view;

FIG. 4 is a bottom plan view;

FIG. 5 is a left side elevational view, with the opposite side being a mirror image thereof; and,

FIG. 6 is a front elevational view.

[56] **References Cited**

U.S. PATENT DOCUMENTS

D. 244,267 5/1977 Fay D12/156

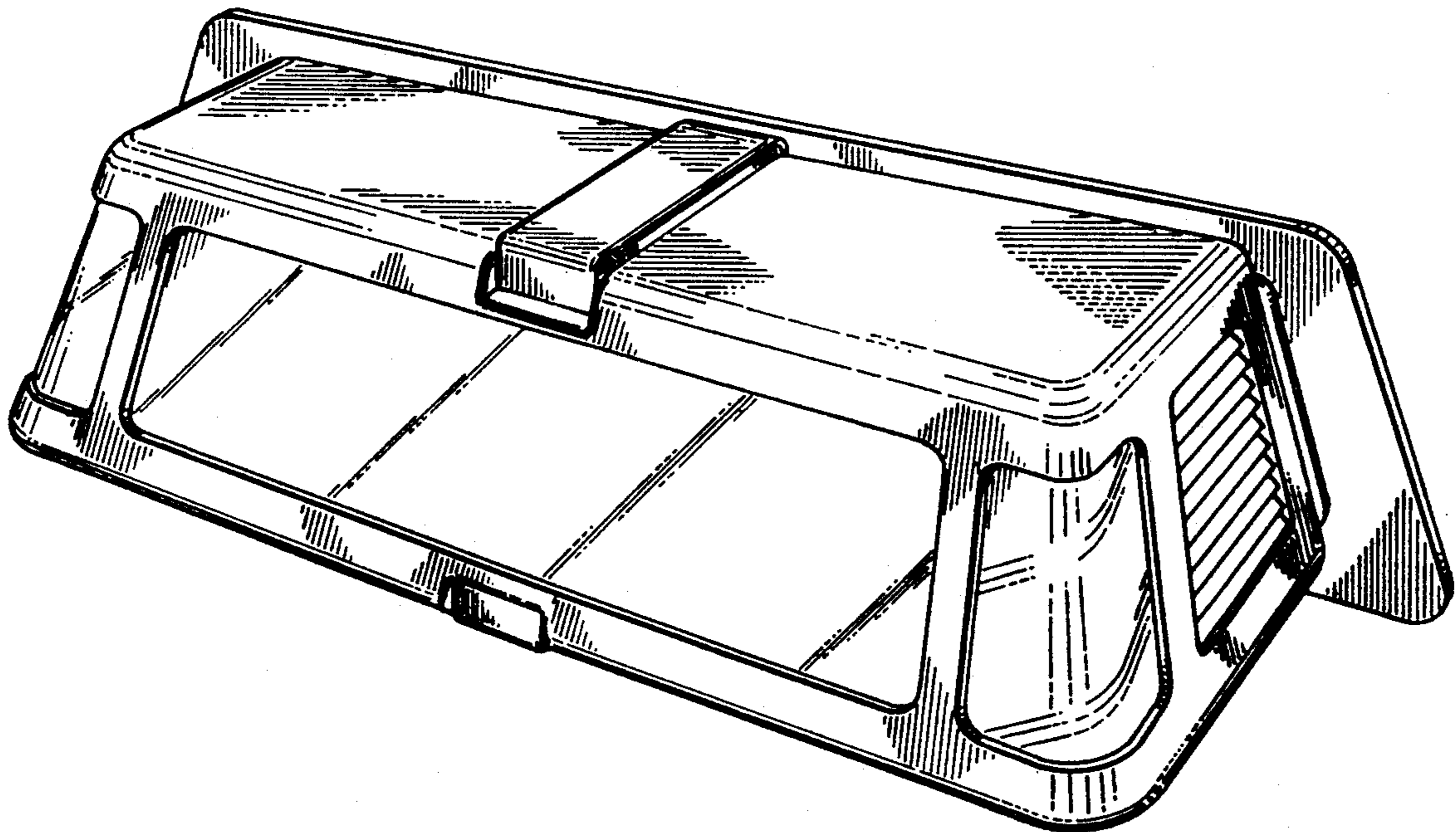

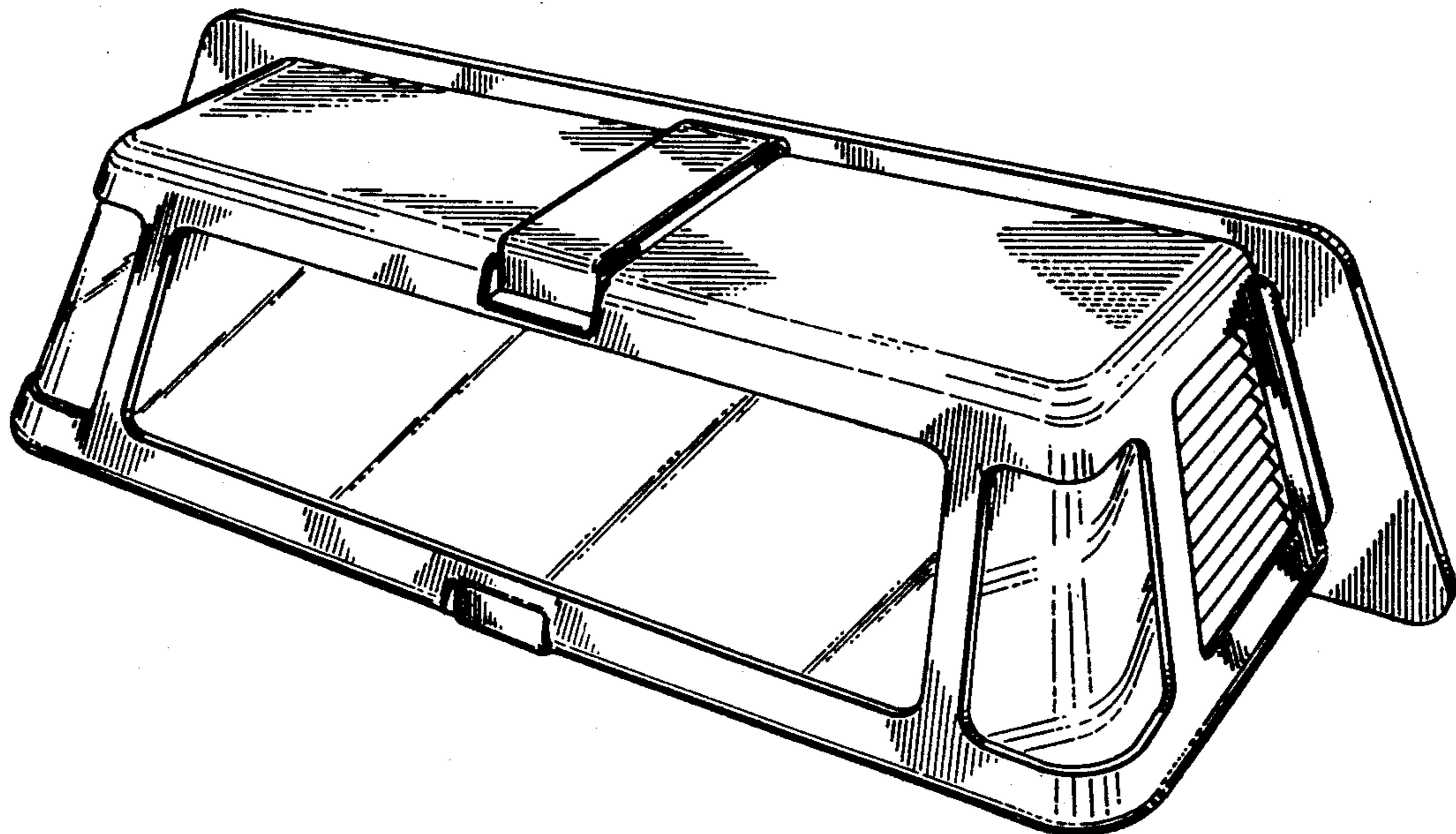

Fig 1

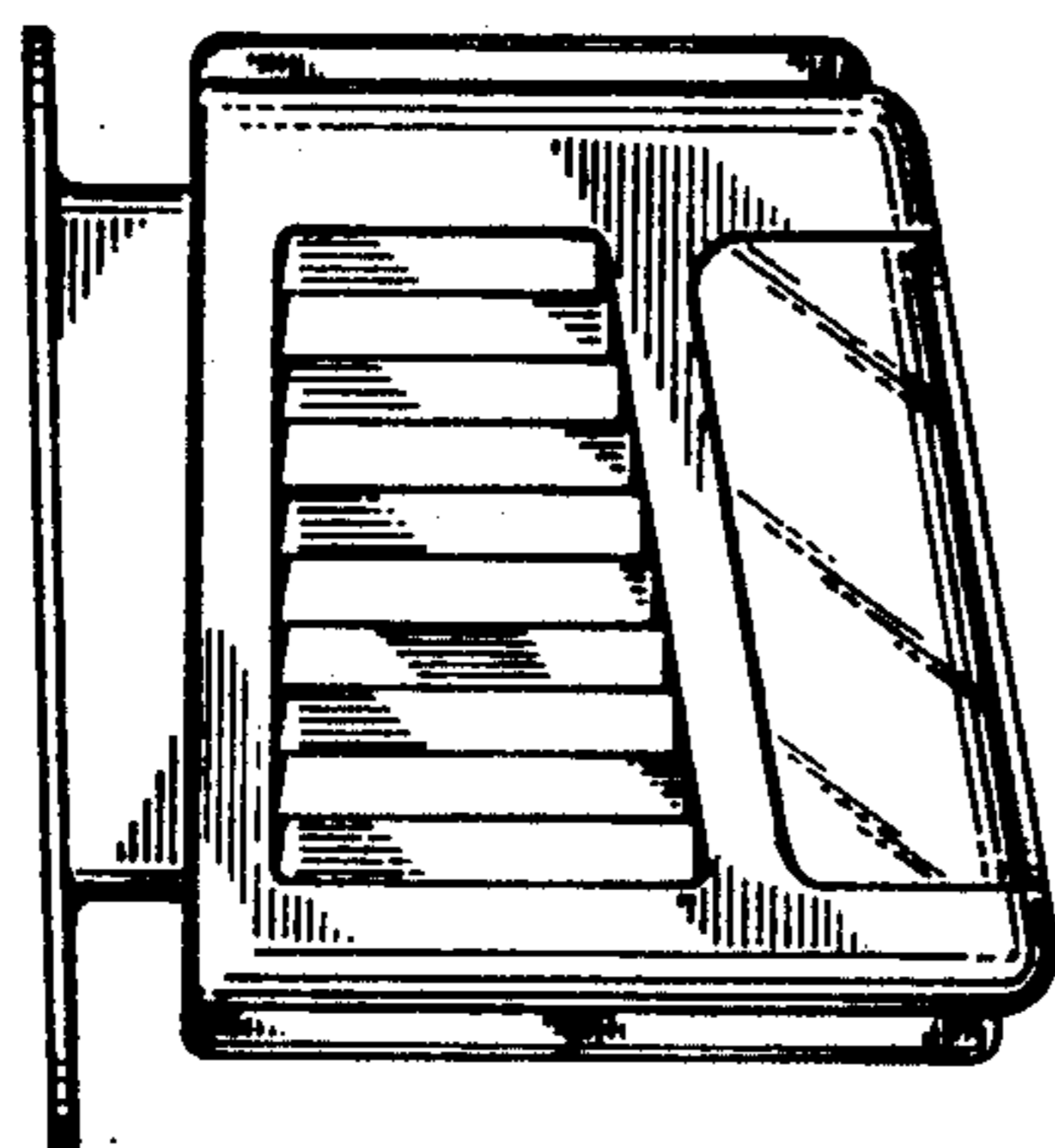

Fig 5

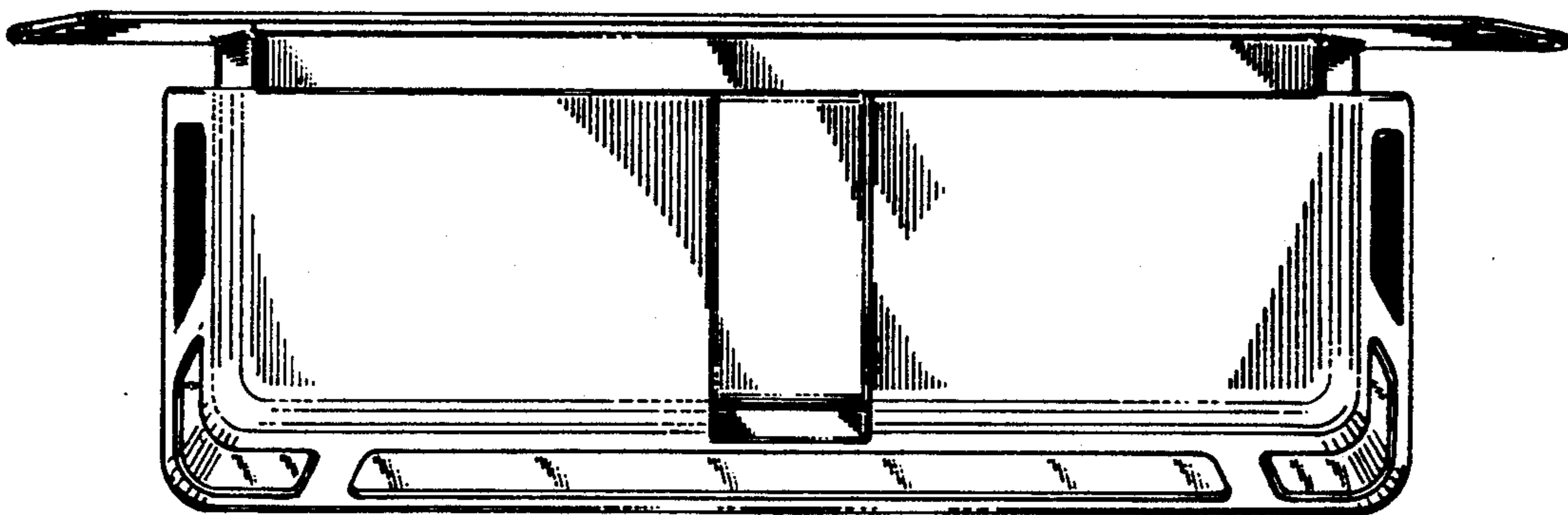

Fig 2

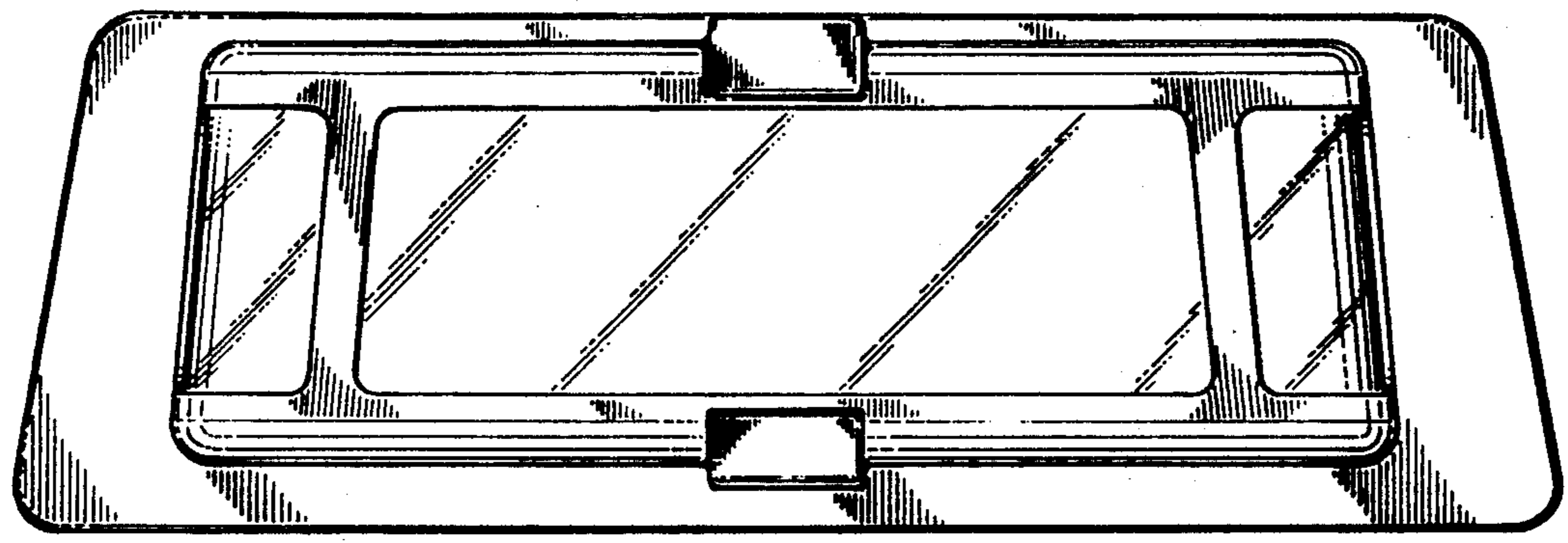

Fig 3

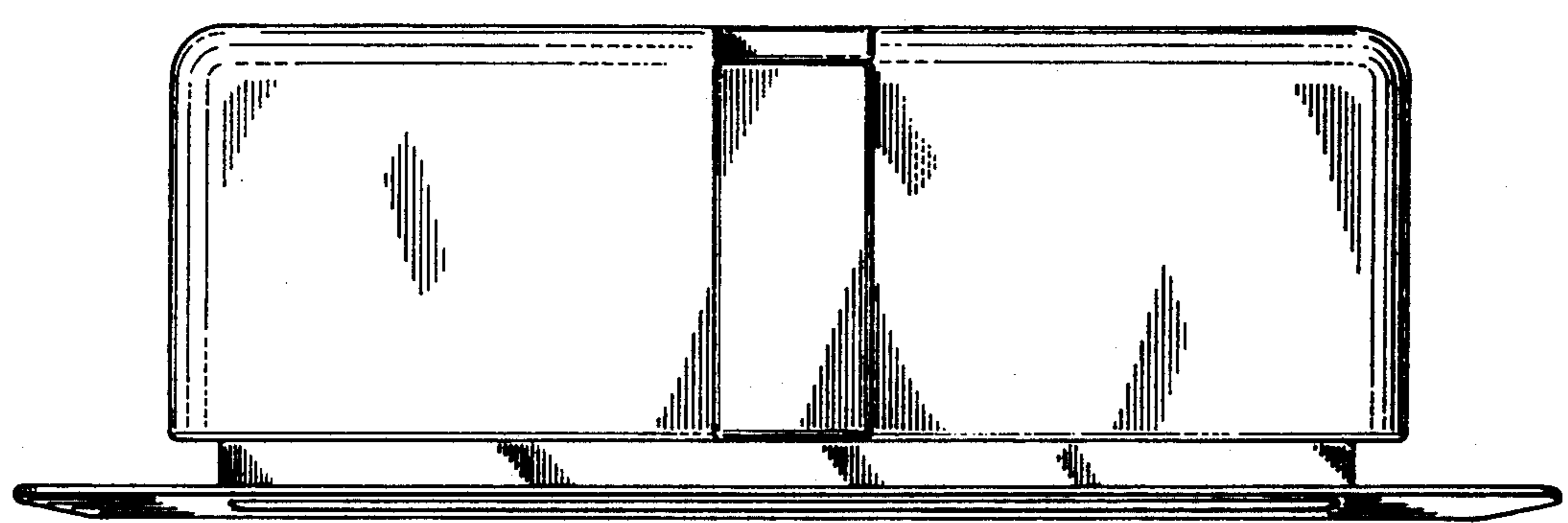

Fig 4

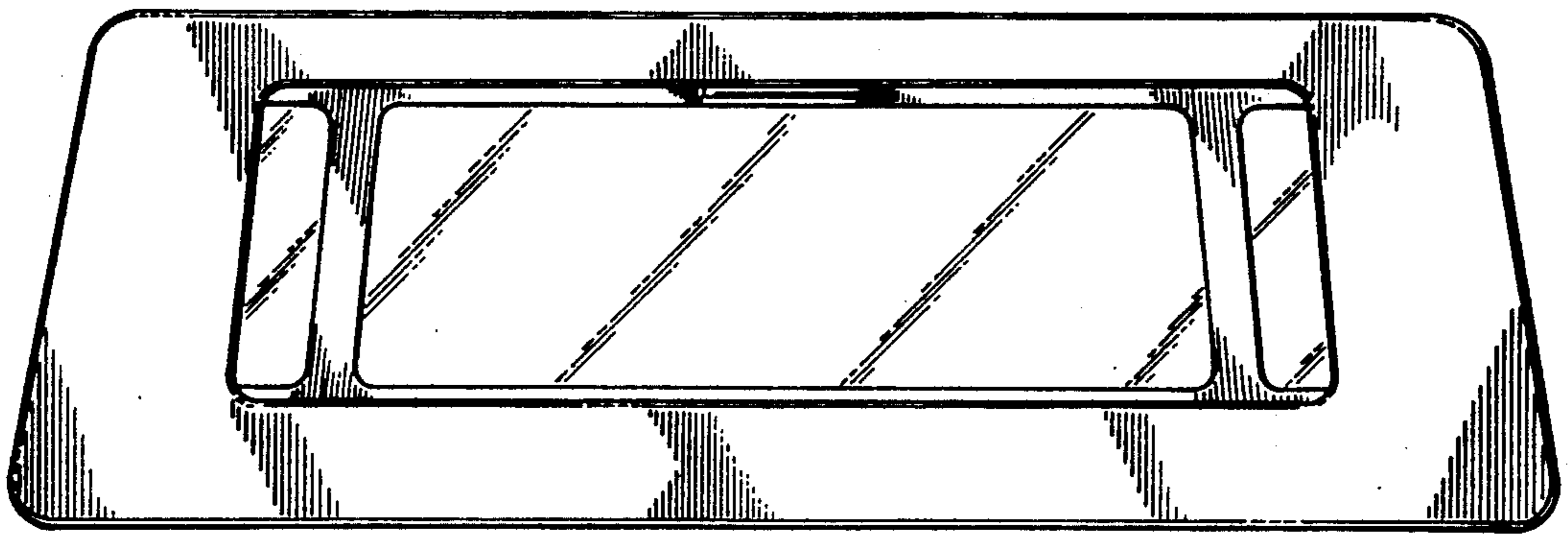

Fig 6

**UNITED STATES PATENT AND TRADEMARK OFFICE
CERTIFICATE OF CORRECTION**

PATENT NO. : Des. 335,116
DATED : April 27, 1993
INVENTOR(S) : Floyd W. Reed et al.

It is certified that error appears in the above-identified patent and that said Letters Patent is hereby corrected as shown below:

In the Title page, item [54]: in the Title, delete "ATTACHMENT TO" and substitute therefor --INSERTION INTO--.

In the Title page, right column, after "Butler 296/99.1" insert

--2,971,794	2/1961	Garcia	296/26
3,249,382	5/1966	Swithenbank	296/26
3,508,786	4/1970	Colville	296/99
4,681,361	7/1987	Jolley et al.	296/37.7
4,892,346	1/1990	Berlin	296/26

OTHER DOCUMENTS

Sleeper Cabs by Pape Enterprises Incorporated,
El Cajon, California, effective 10/1/89--.

In the Title page, right column, under CLAIM, line 1, delete "attachment to" and substitute therefor --insertion into--.

In the Title page, right column, under DESCRIPTION, lines 1 and 2, delete "attachment to" and substitute therefor --insertion into--.

Signed and Sealed this
Twelfth Day of July, 1994

Attest:



BRUCE LEHMAN

Attesting Officer

Commissioner of Patents and Trademarks