



US00D334907S

United States Patent [19]

[11] Patent Number: **Des. 334,907**

Boyer

[45] Date of Patent: **** Apr. 20, 1993**

[54] **AUTOMOBILE**

[75] Inventor: **Boyke Boyer**, Seefeld, Fed. Rep. of Germany

[73] Assignee: **Bayerische Motoren Werke AG**, Fed. Rep. of Germany

[**] Term: **14 Years**

[21] Appl. No.: **610,992**

[22] Filed: **Nov. 6, 1990**

[30] **Foreign Application Priority Data**

May 18, 1990 [DE] Fed. Rep. of Germany 9003568

[52] U.S. Cl. **D12/92**

[58] Field of Search D12/92; 296/185

[56] **References Cited**

PUBLICATIONS

Road & Track, Jan. 1989, p. 125, BMW 535i Automobile.

Motor Trend, Sep. 1986, p. 22, Jaguar XJ40 Automobile, top of page.

Motor Trend, Jan. 1986, p. 19, Auston Martin Vantage Zagato Automobile, top of page.

Autocar & Motor, Aug. 30, 1989, p. 7, BMW 7-Series Automobile, top of page.

Primary Examiner—James M. Gandy
Attorney, Agent, or Firm—Evenson, Wands, Edwards, Lenahan & McKeown

[57] **CLAIM**

The ornamental design for an automobile, as shown and described.

DESCRIPTION

FIG. 1 is a front perspective view of an automobile embodying my novel design;

FIG. 2 is a rear perspective view thereof;

FIG. 3 is a left side elevation view thereof;

FIG. 4 is a right side elevation view thereof;

FIG. 5 is a left side perspective view taken from the rear thereof;

FIG. 6 is a left side perspective view taken from the front thereof; and,

FIG. 7 is a top perspective view thereof.

The broken line showing of environmental structure in FIGS. 1, 2, 5, 6 and 7 of the drawing is for illustrative purposes only and forms no part of the claimed design.

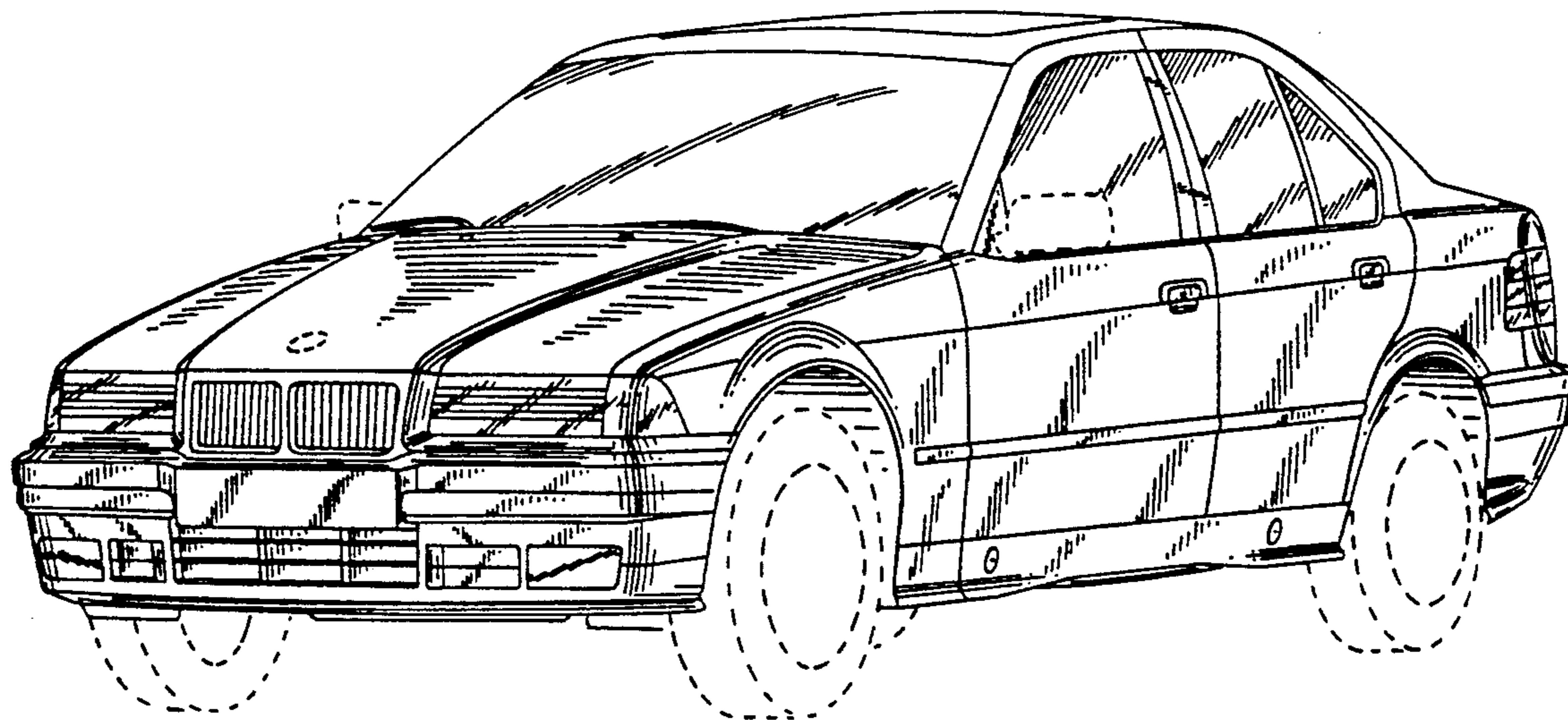

FIG. 1

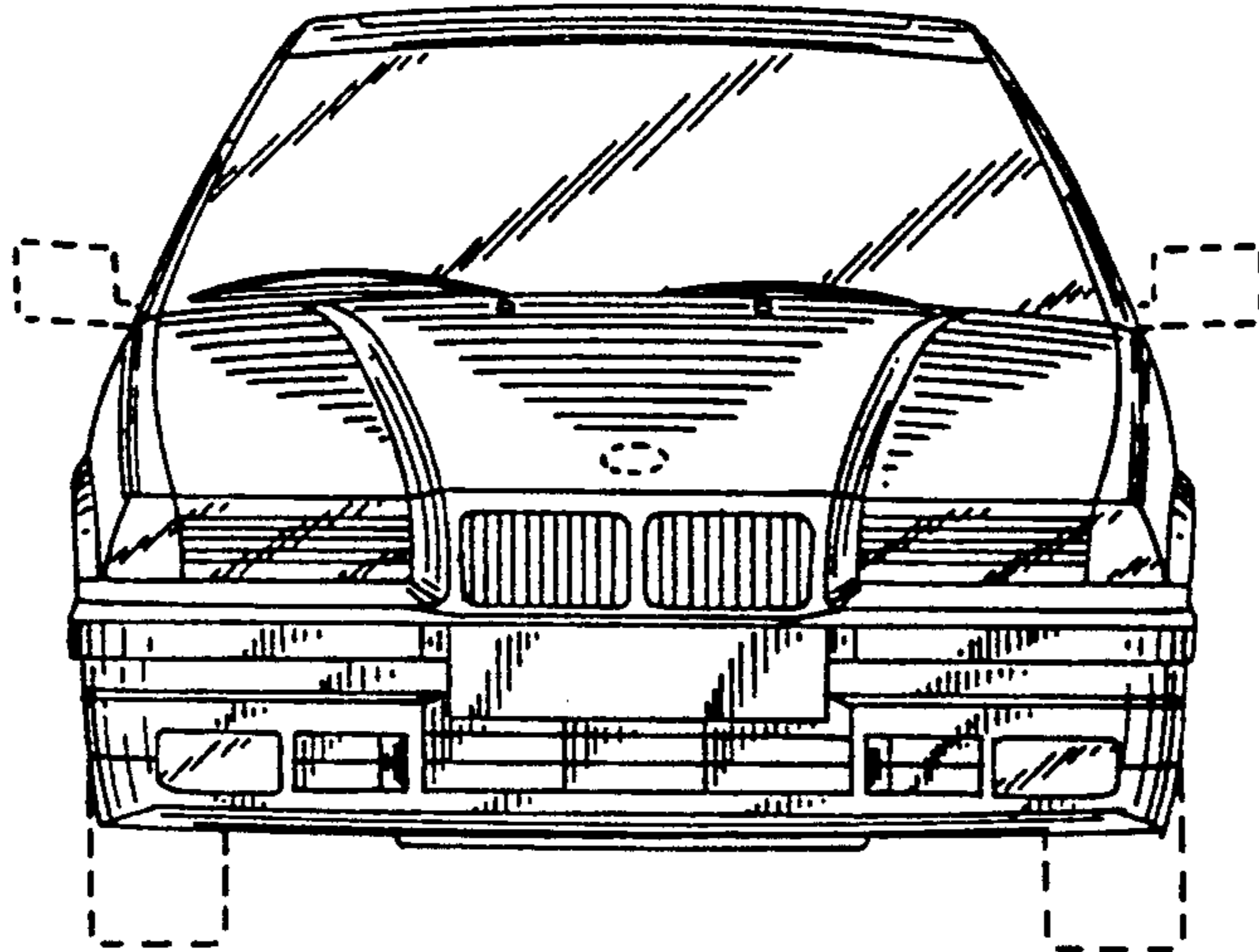

FIG. 2

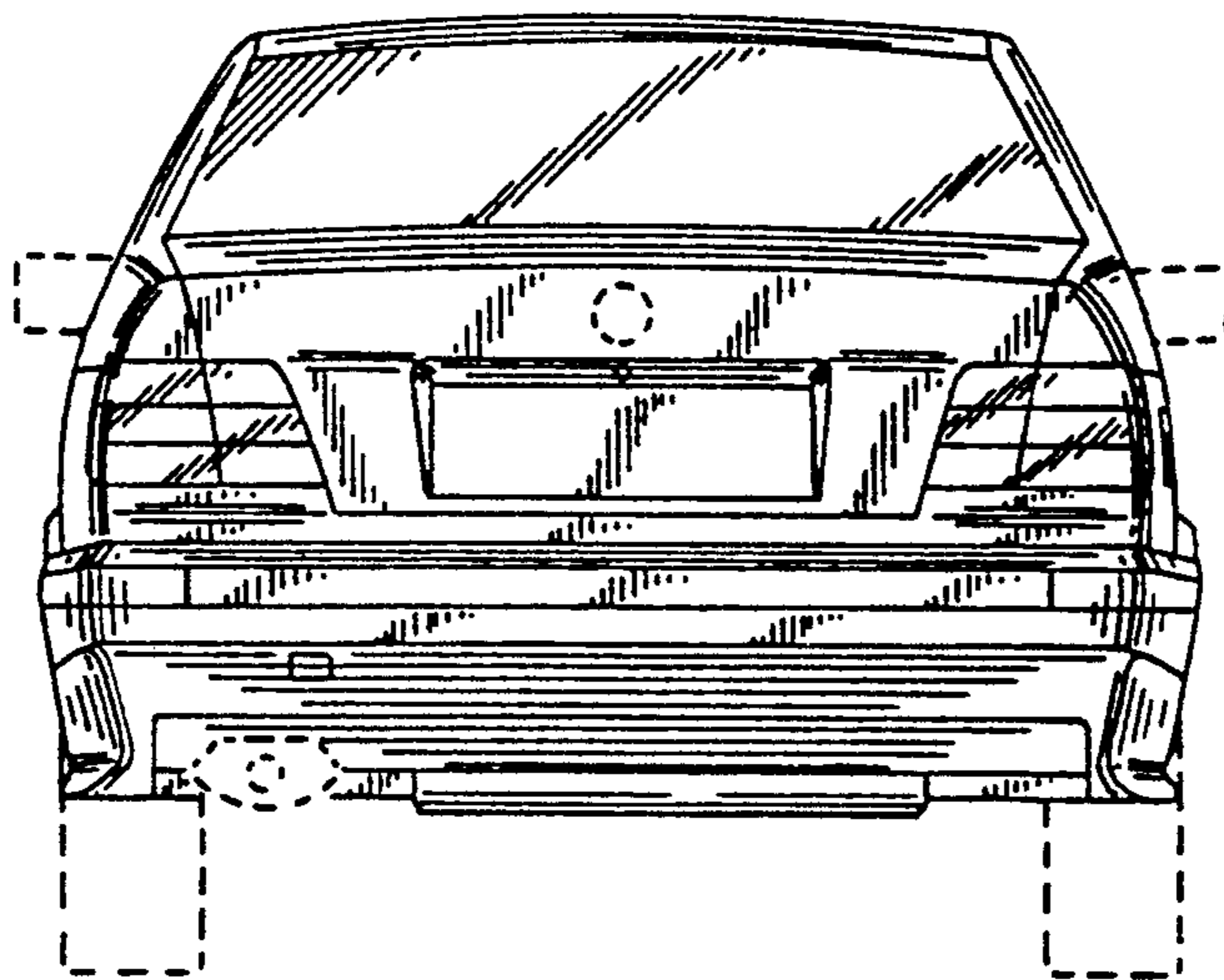

FIG. 3

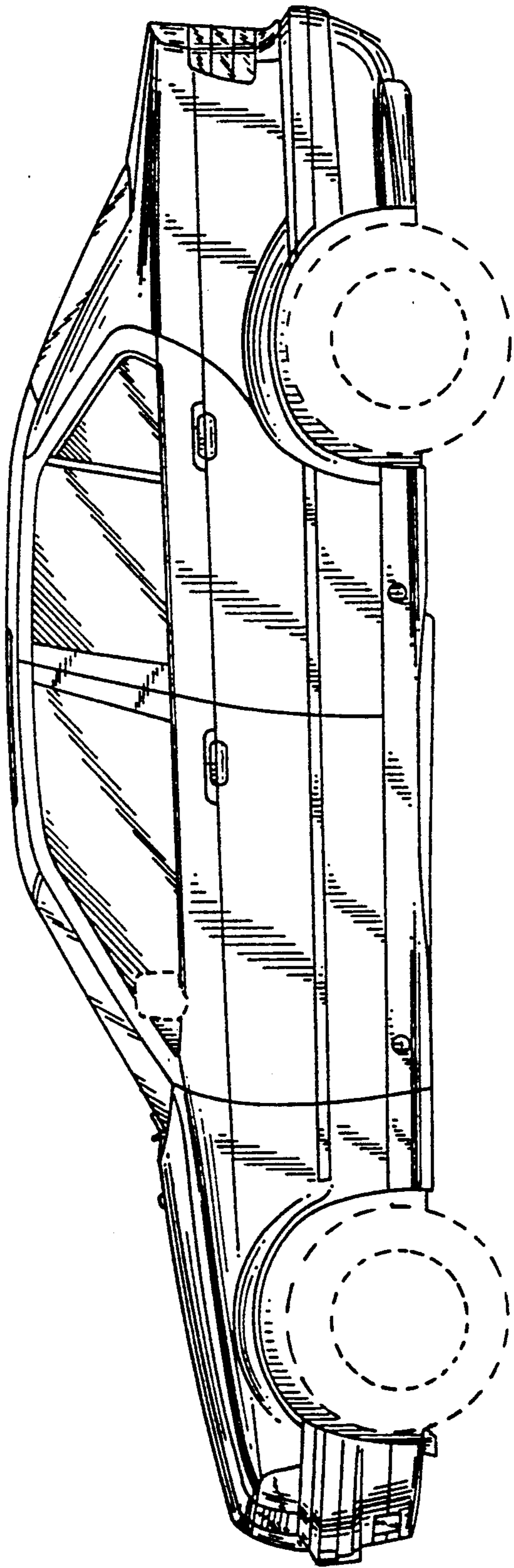

FIG. 4

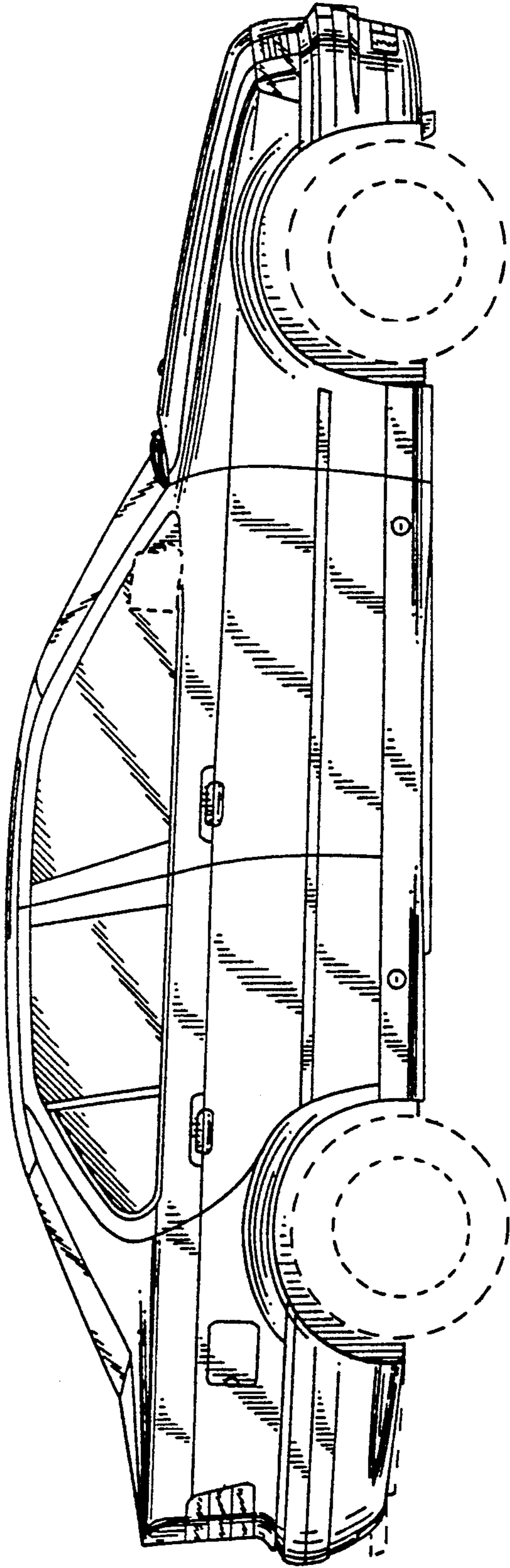

FIG. 5

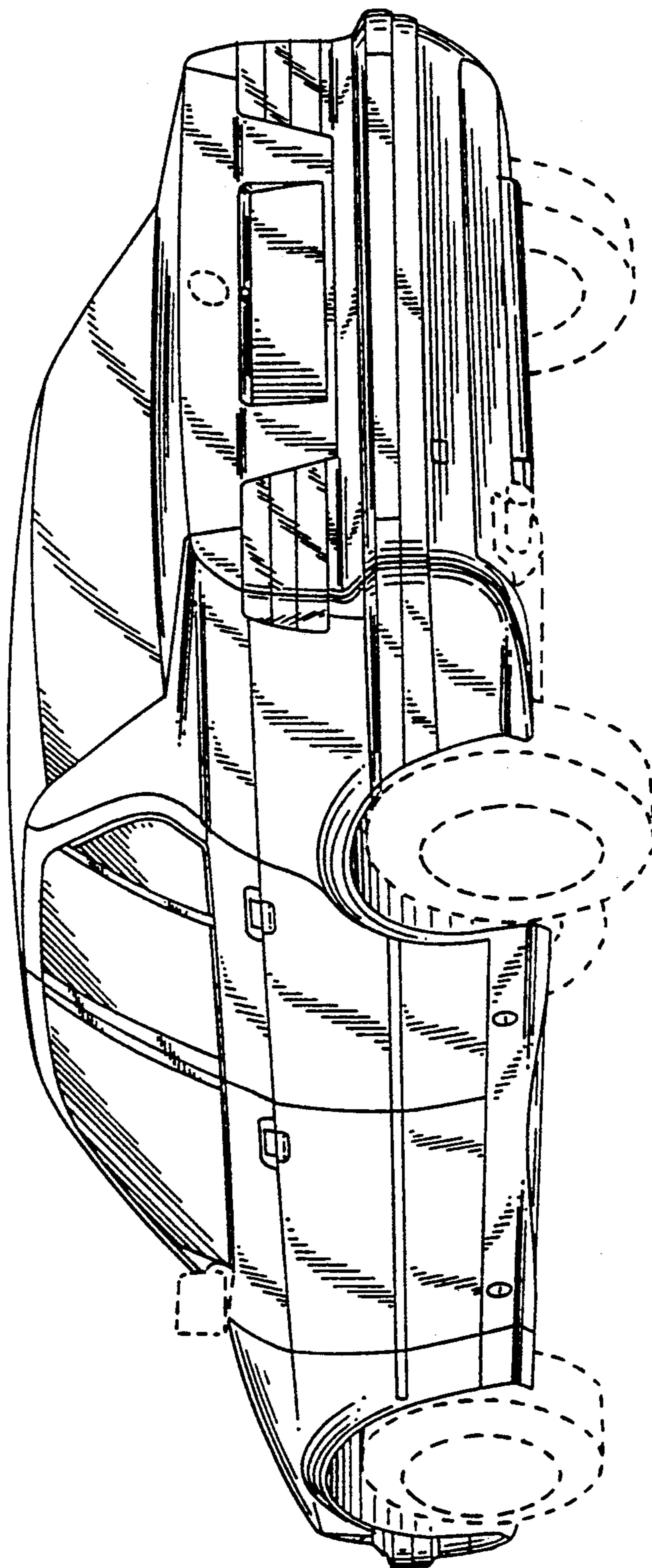

FIG. 6

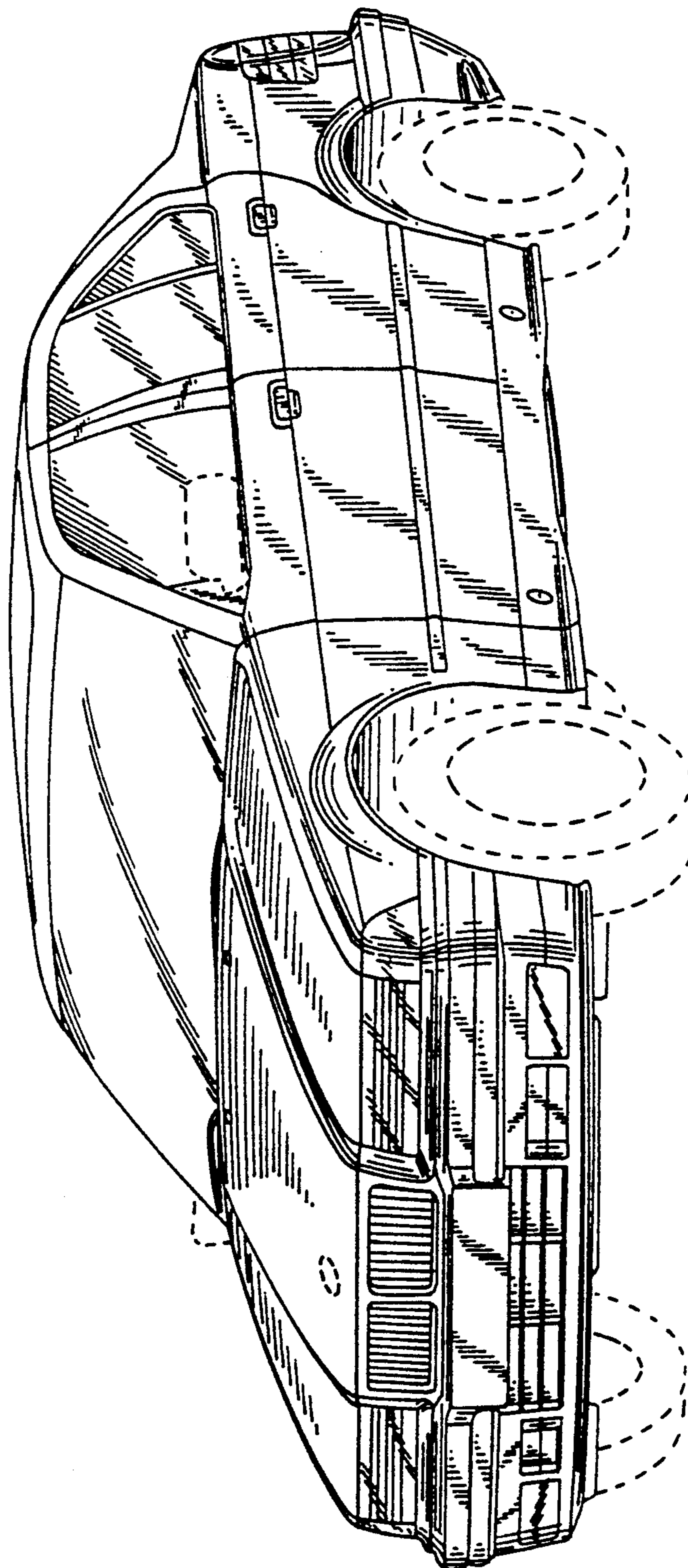

FIG. 7

