



US00D334623S

# United States Patent [19]

[11] Patent Number: **Des. 334,623**

Burton et al.

[45] Date of Patent: **\*\* Apr. 6, 1993**

[54] **TRACTION UNIT FOR REMOVING LOADING FROM THE BACK**

[75] Inventors: **Charles V. Burton, Excelsior; Gregory K. Peterson, North Oaks; Casey L. Carlson, Edina; Jeffrey A. Weber; William E. Stumpf, both of Minneapolis, all of Minn.**

[73] Assignee: **Spinal Designs International, Inc., Minneapolis, Minn.**

[\*\*] Term: **14 Years**

[21] Appl. No.: **473,686**

[22] Filed: **Feb. 1, 1990**

[52] U.S. Cl. .... **D24/188**

[58] Field of Search ..... **D24/188; 128/78, 83.5, 128/68, 75, 79; 602/36, 19**

[56] **References Cited**

**U.S. PATENT DOCUMENTS**

|            |         |                     |         |
|------------|---------|---------------------|---------|
| D. 296,590 | 7/1988  | Cottrell .....      | D24/188 |
| D. 310,882 | 9/1990  | Pope .....          | D24/188 |
| 1,356,365  | 10/1920 | Hosmer .            |         |
| 2,984,238  | 5/1961  | Axtell et al. ....  | 128/75  |
| 3,103,357  | 9/1963  | Berne .....         | 272/79  |
| 3,167,068  | 1/1965  | Carr .....          | 128/75  |
| 3,353,532  | 11/1967 | Ellis .....         | 128/75  |
| 3,396,012  | 8/1983  | Cobiski .....       | 128/75  |
| 4,030,489  | 6/1977  | Buckner .....       | 128/75  |
| 4,205,665  | 6/1980  | Burton .....        | 128/68  |
| 4,269,179  | 5/1981  | Burton et al. ....  | 128/75  |
| 4,422,452  | 12/1983 | Burton .....        | 128/75  |
| 4,515,152  | 5/1985  | Teeter .....        | 128/75  |
| 4,569,340  | 2/1986  | Burton .....        | 128/75  |
| 4,583,533  | 4/1986  | Goodley et al. .... | 128/75  |
| 4,603,689  | 8/1986  | Horner .....        | 128/75  |
| 4,617,919  | 10/1986 | Suhre .....         | 128/78  |

|           |         |                  |         |
|-----------|---------|------------------|---------|
| 4,688,557 | 8/1987  | Bradstreet ..... | 128/71  |
| 4,715,362 | 12/1987 | Scott .....      | 128/75  |
| 4,725,055 | 2/1988  | Skowronski ..... | 272/134 |
| 4,746,116 | 5/1988  | Inada .....      | 272/144 |
| 4,854,305 | 8/1989  | Bremer .....     | 128/75  |
| 4,881,528 | 11/1989 | Scott .....      | 128/75  |
| 5,033,459 | 7/1991  | Burton .....     | 128/71  |
| 5,088,476 | 2/1992  | Burton .....     | 606/241 |
| 5,105,803 | 4/1992  | Burton .....     | 602/36  |

**FOREIGN PATENT DOCUMENTS**

|            |         |                        |
|------------|---------|------------------------|
| 980199     | 12/1975 | Canada .               |
| 2363390    | 6/1975  | Fed. Rep. of Germany . |
| 3104832A1  | 1/1983  | Fed. Rep. of Germany . |
| 3420858A1  | 12/1985 | Fed. Rep. of Germany . |
| 1371332    | 7/1964  | France .               |
| 797664     | 1/1981  | U.S.S.R. .             |
| 812280     | 3/1981  | U.S.S.R. .             |
| WO80/01540 | 8/1980  | World Int. Prop. O. .  |
| WO89/10732 | 11/1989 | World Int. Prop. O. .  |

*Primary Examiner*—Stella Reid  
*Attorney, Agent, or Firm*—Merchant, Gould, Smith, Edell, Welter & Schmidt

[57] **CLAIM**

The ornamental design for a traction unit for removing loading from the back, as shown and described.

**DESCRIPTION**

FIG. 1 is a perspective view of a traction unit for removing loading from the back, showing our new design;  
FIG. 2 is a top plan view thereof;  
FIG. 3 is a front elevational view thereof;  
FIG. 4 is a bottom plan view thereof;  
FIG. 5 is a right side elevational view thereof;  
FIG. 6 is a left side elevational view thereof; and,  
FIG. 7 is a rear elevational view thereof.

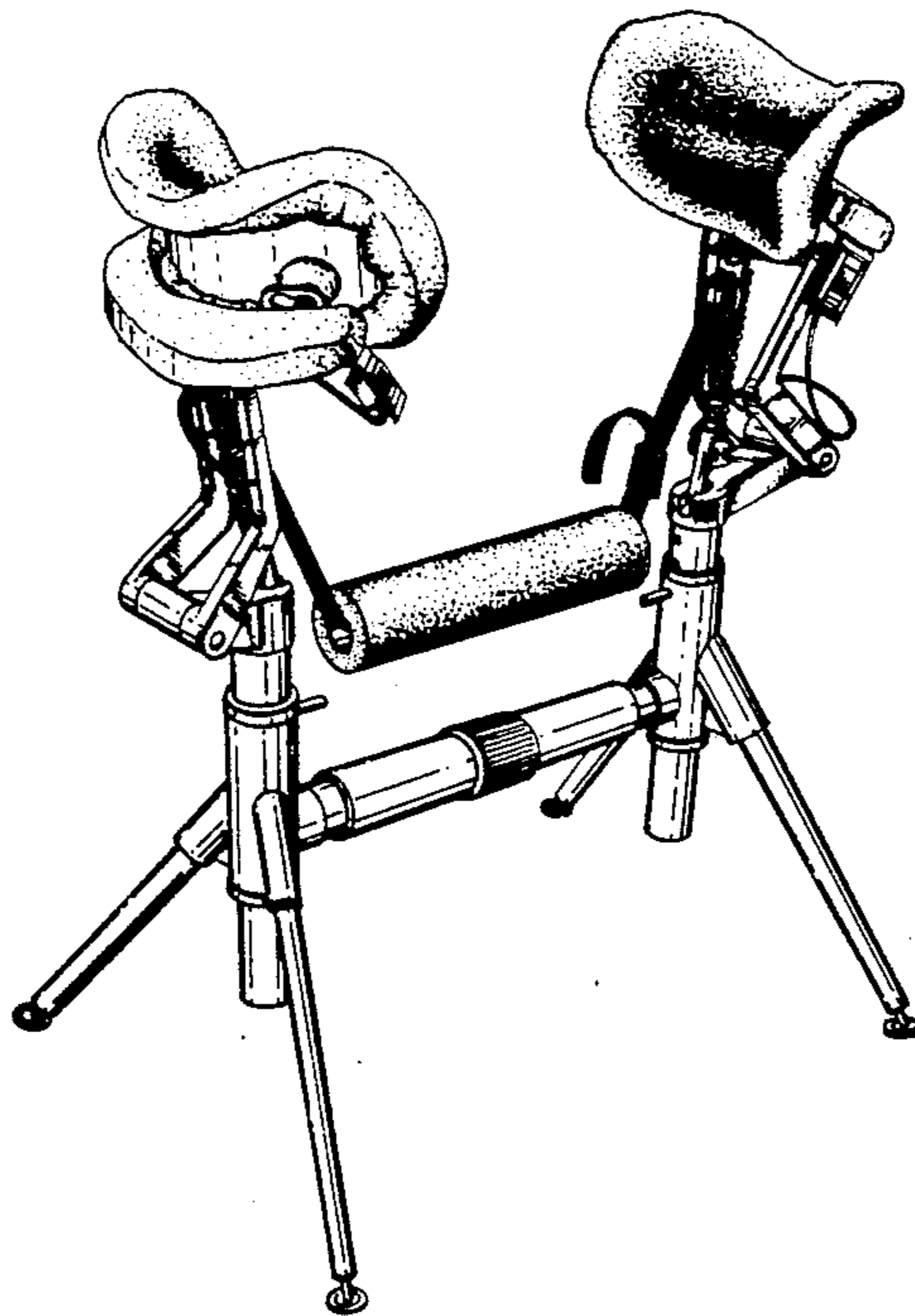
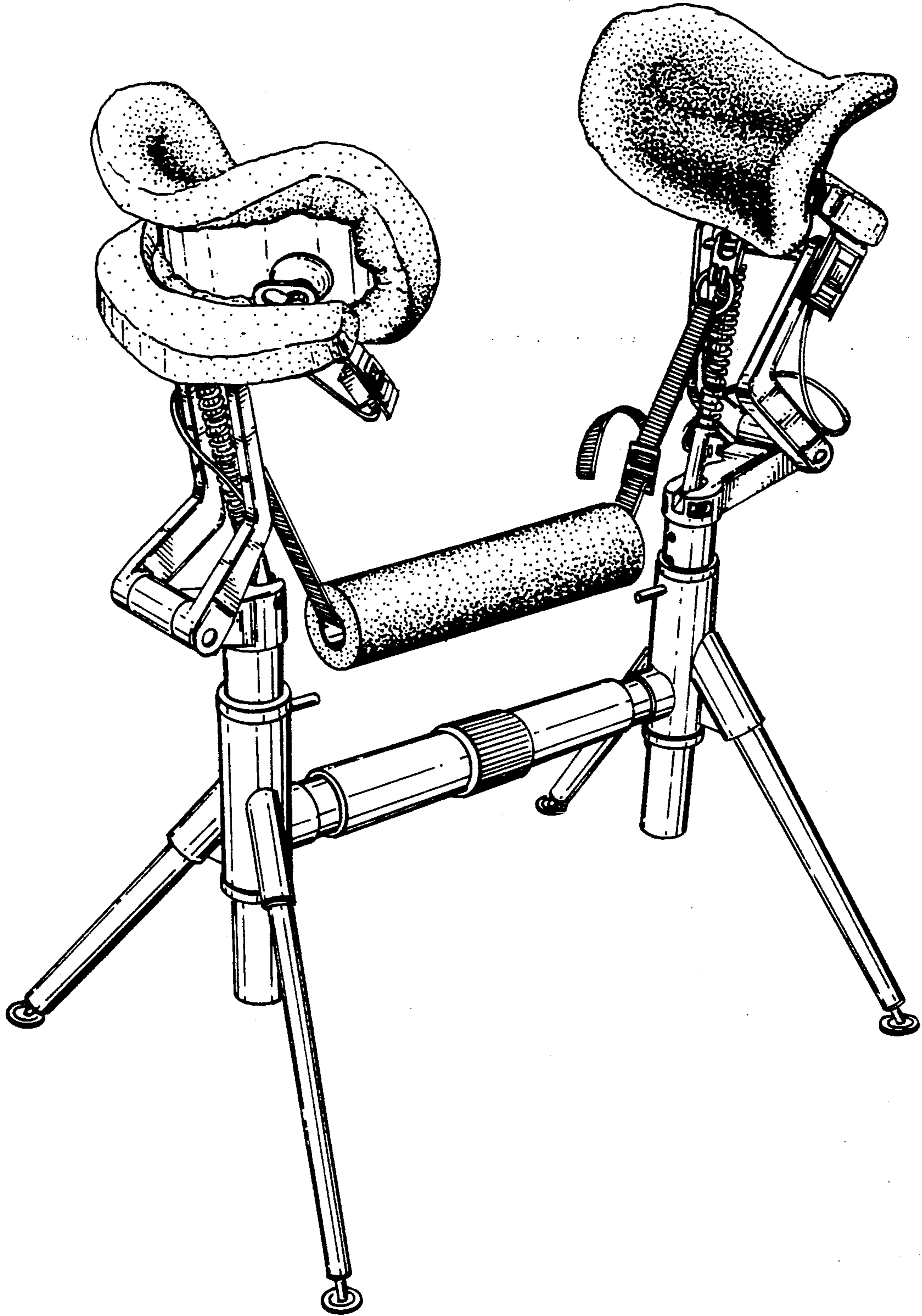

FIG. 1



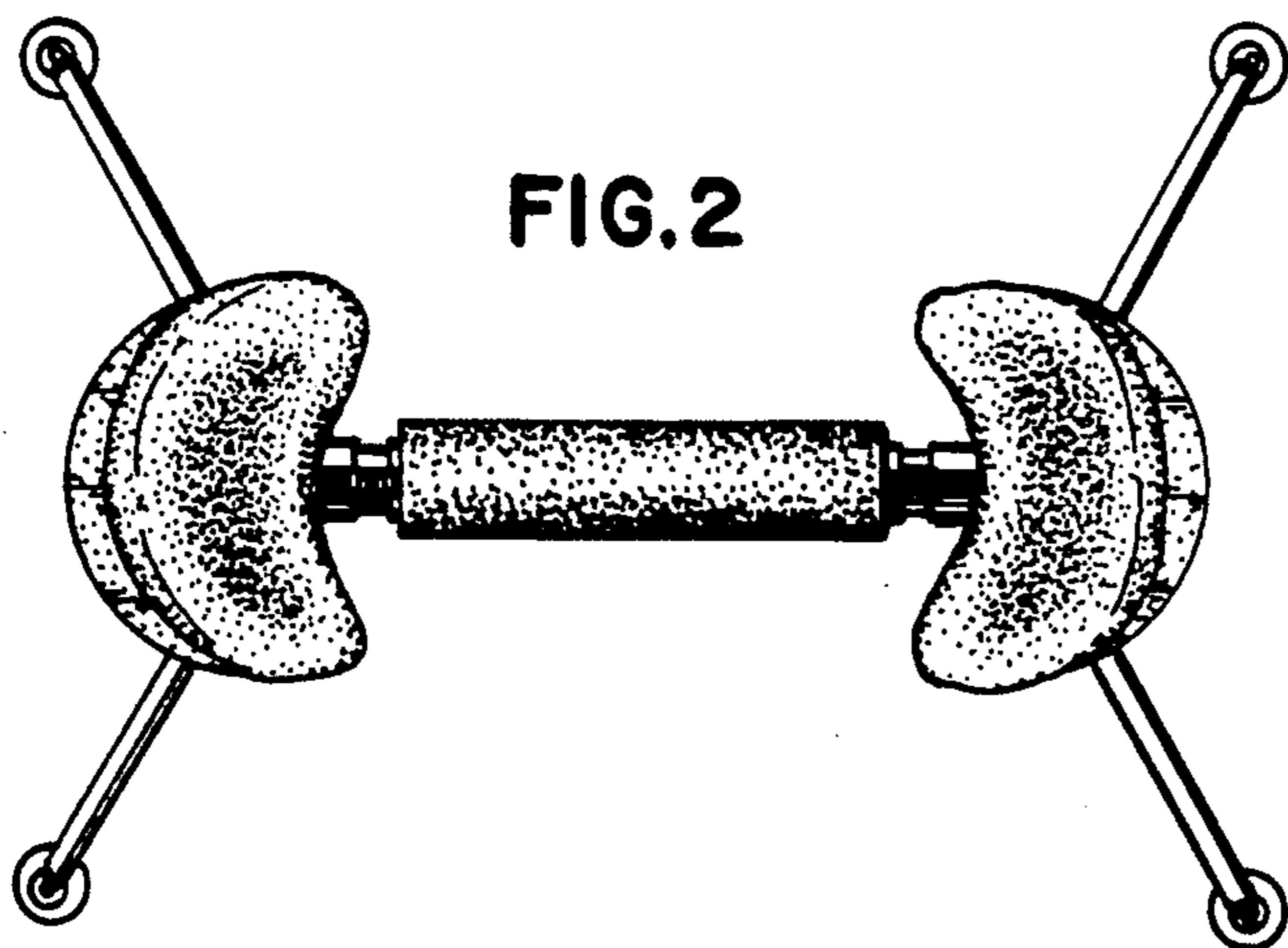

FIG. 2

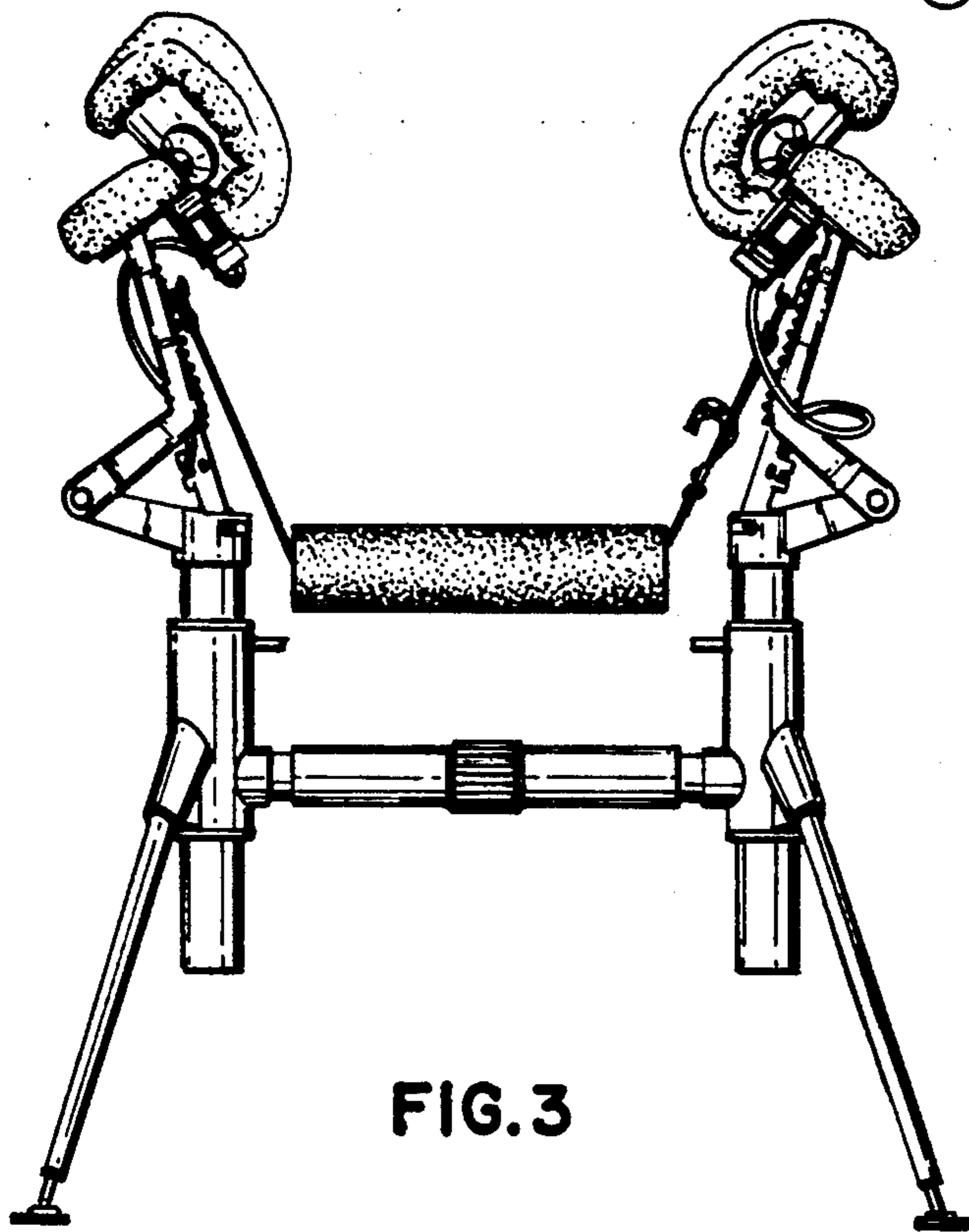

FIG. 3

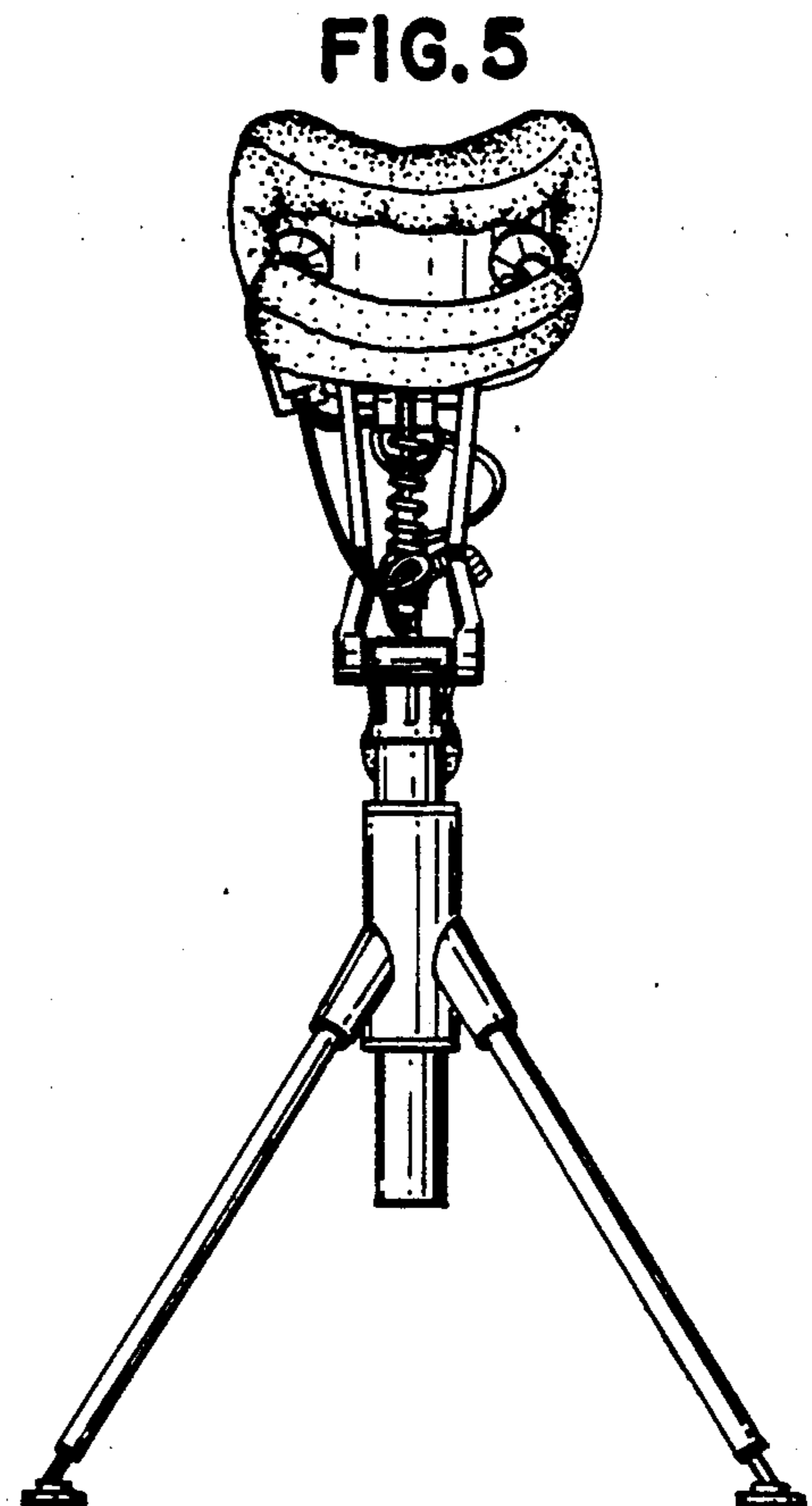

FIG. 5

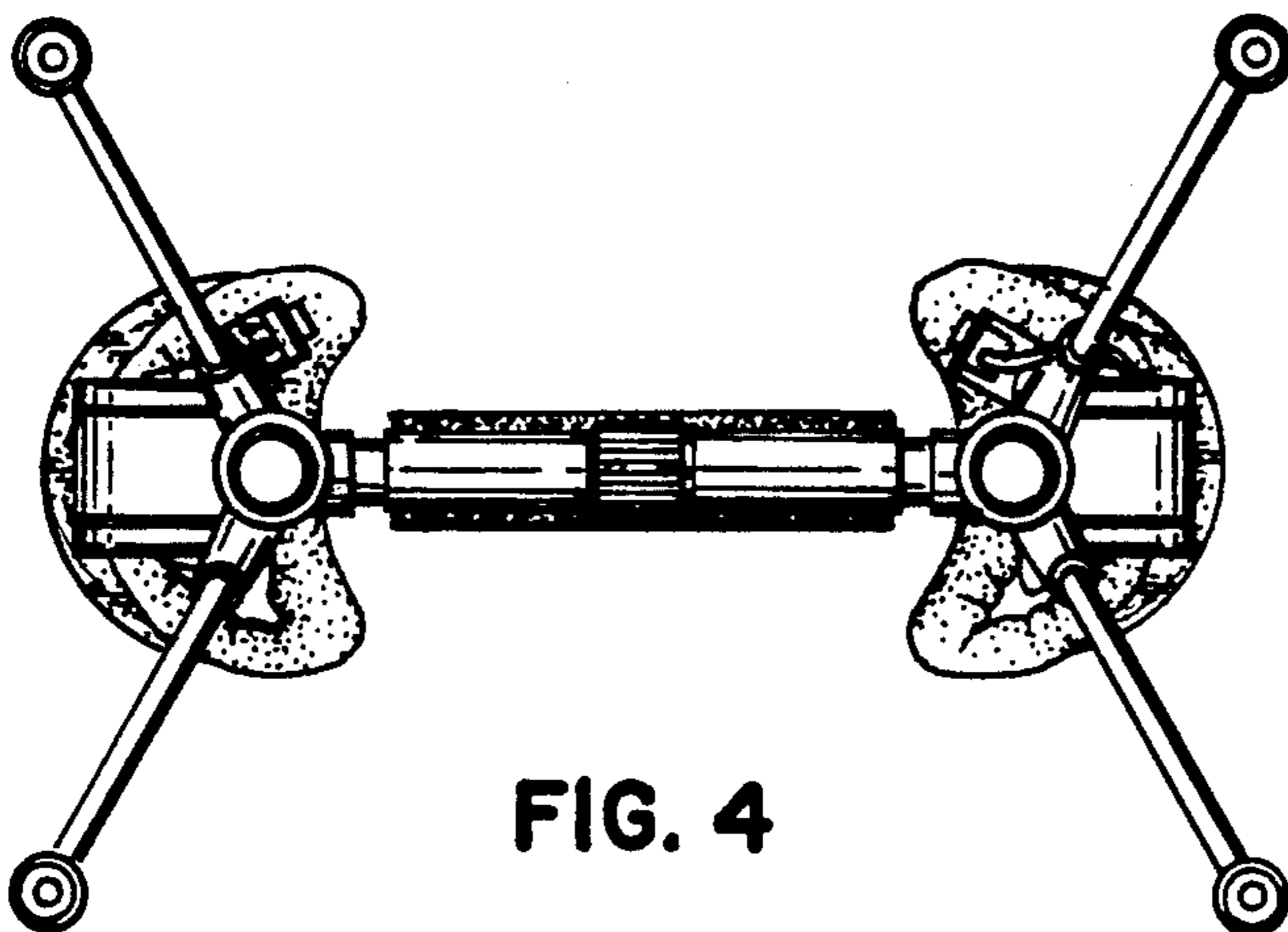

FIG. 4

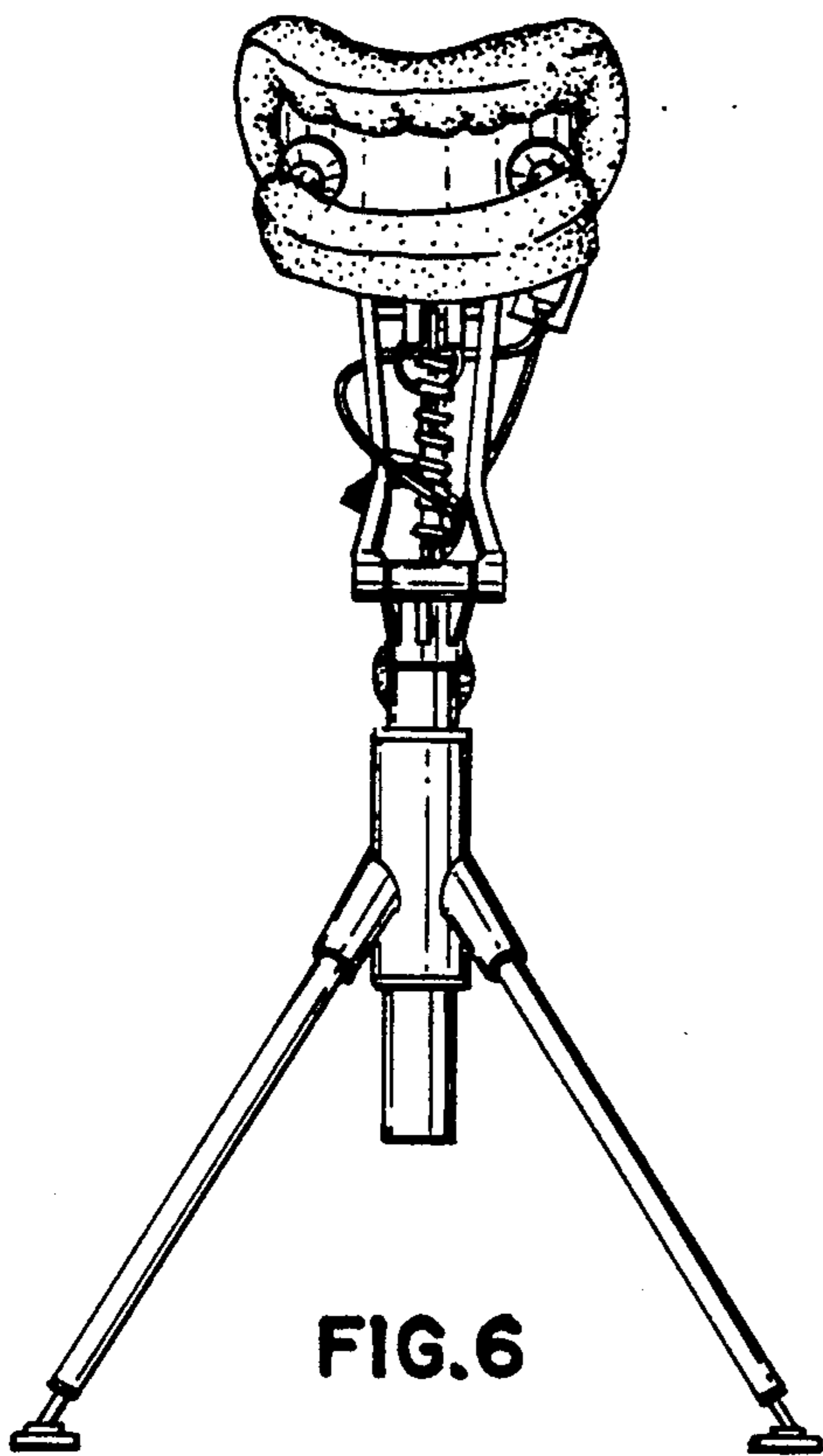

FIG. 6

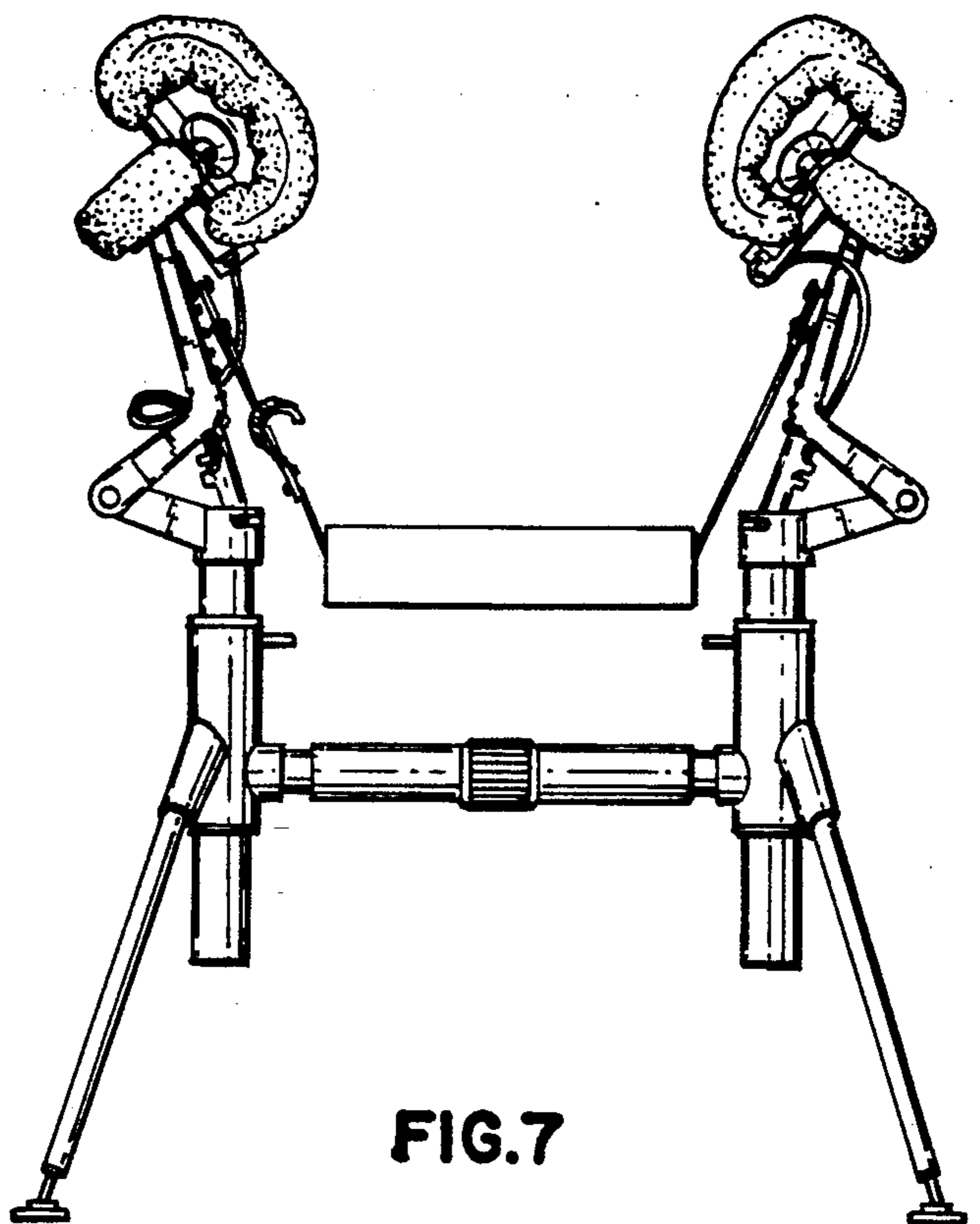

FIG. 7