



US00D334164S

United States Patent [19]
Klieber

[11] **Patent Number: Des. 334,164**
[45] **Date of Patent: ** Mar. 23, 1993**

[54] **CLIP-ON AEROBAR FOR BICYCLES**

[76] **Inventor: Jochen Klieber, Dammweg 1 D-8221, Tacherting, Fed. Rep. of Germany**

[**] **Term: 14 Years**

[21] **Appl. No.: 728,254**

[22] **Filed: Jul. 10, 1991**

[52] **U.S. Cl. D12/178**

[58] **Field of Search D12/178; 74/551.1, 551.8, 74/551.9, 551.3**

[56] **References Cited**

U.S. PATENT DOCUMENTS

D. 283,209	4/1986	Rodriguez	D12/114
D. 315,328	3/1991	Giard, Jr.	D12/178
D. 323,805	2/1992	Giard, Jr.	D12/178
4,878,397	11/1989	Lennon	74/551.1
4,951,525	8/1990	Borromeo	74/551.8
5,000,469	3/1991	Smith	74/551.9
5,094,322	3/1992	Casillas	74/551.8
5,154,094	10/1992	Klieber	74/551.8

OTHER PUBLICATIONS

American Bicyclist & Motorcyclist, Apr. 1991, p. 42, Clip On Handlebars.
American Bicyclist & Motorcyclist, Dec. 1990, p. 48, the Unelli clip on handlebars.

Primary Examiner—Wallace R. Burke
Assistant Examiner—Melody Brown
Attorney, Agent, or Firm—Tilton, Fallon, Lungmus

[57] **CLAIM**

The ornamental design for a clip-on aerobar for bicycles, as shown.

DESCRIPTION

FIG. 1 is a right side perspective view of the design of a clip-on aerobar for bicycles of the present invention, viewed from the top and front; FIG. 2 is a front elevation view of the design of FIG. 1; FIG. 3 is a top plan view of the design of FIG. 1; FIG. 4 is a left side elevation view of the present design, the right side elevation view being a mirror image of that shown; FIG. 5 is a bottom plan view; and, FIG. 6 is a rear elevation view.
My new design of a clip-on aerobar for bicycles may be applied to different conventional styles of bicycle handlebars.

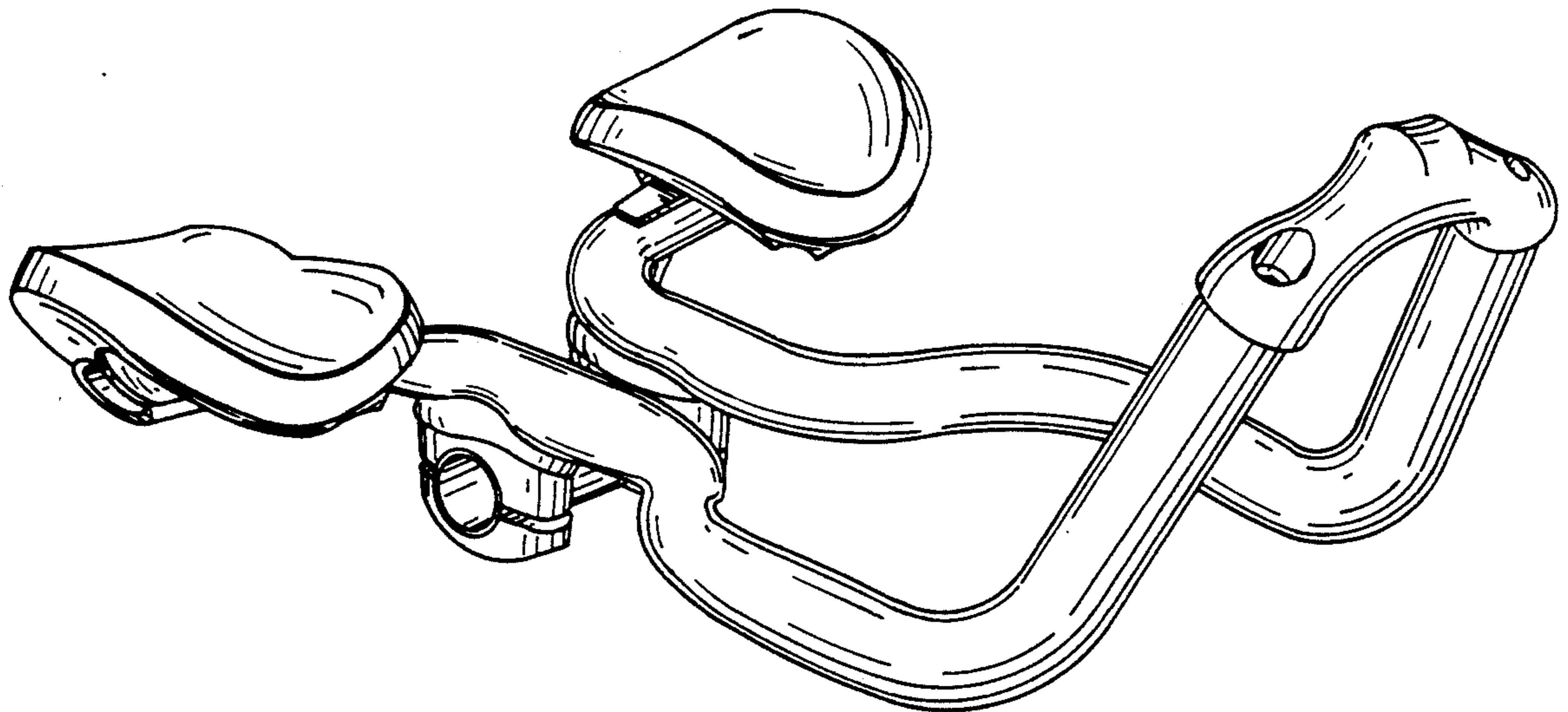

Fig. 1

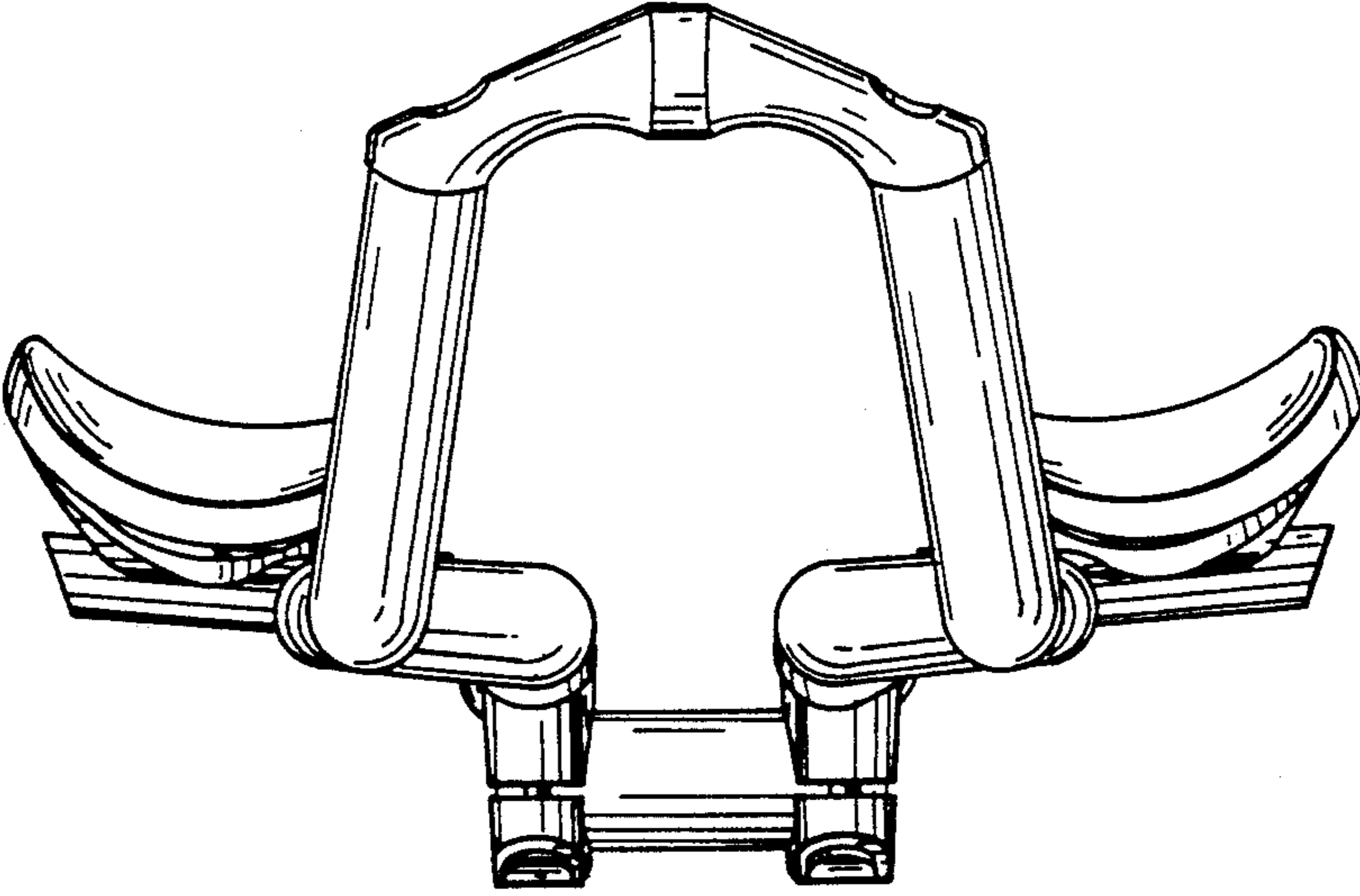
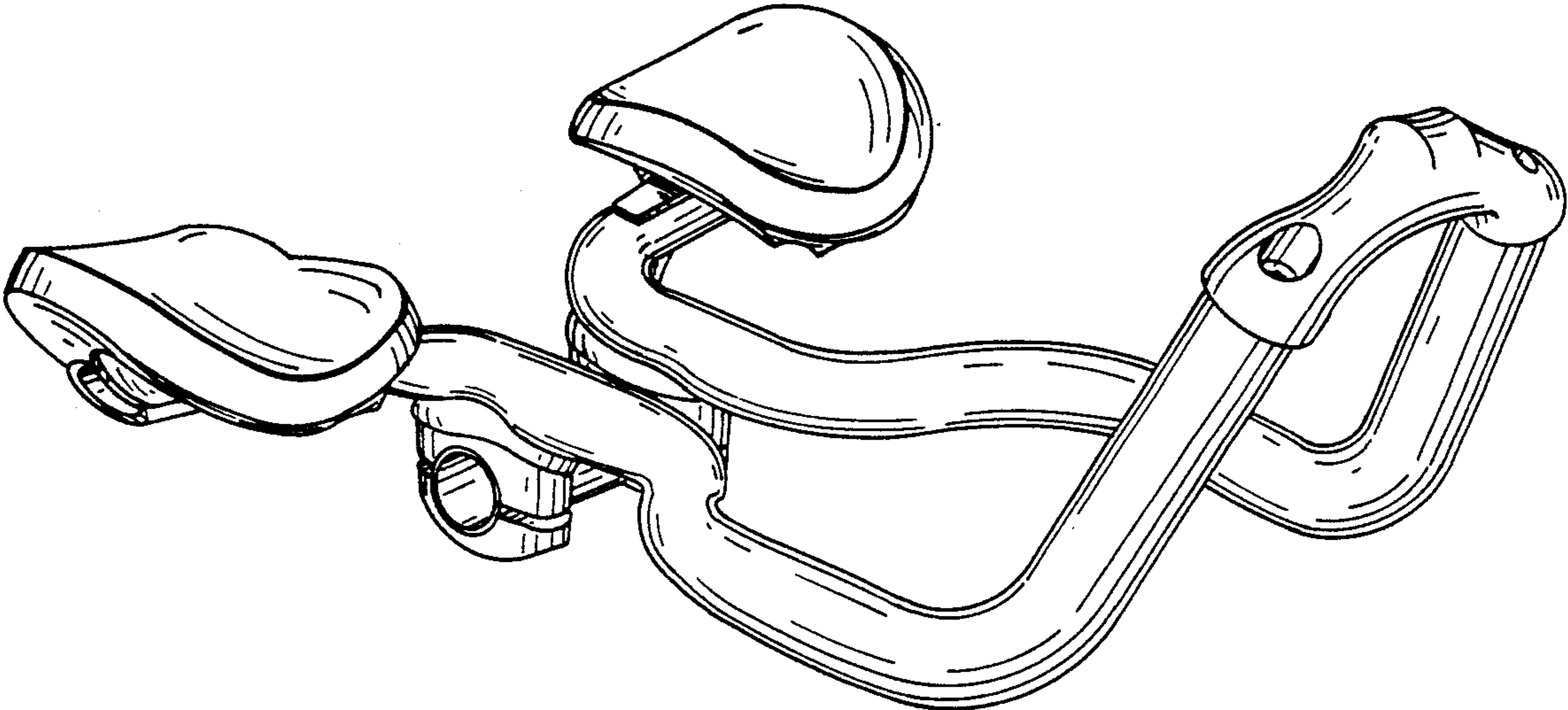

Fig. 2

Fig. 3

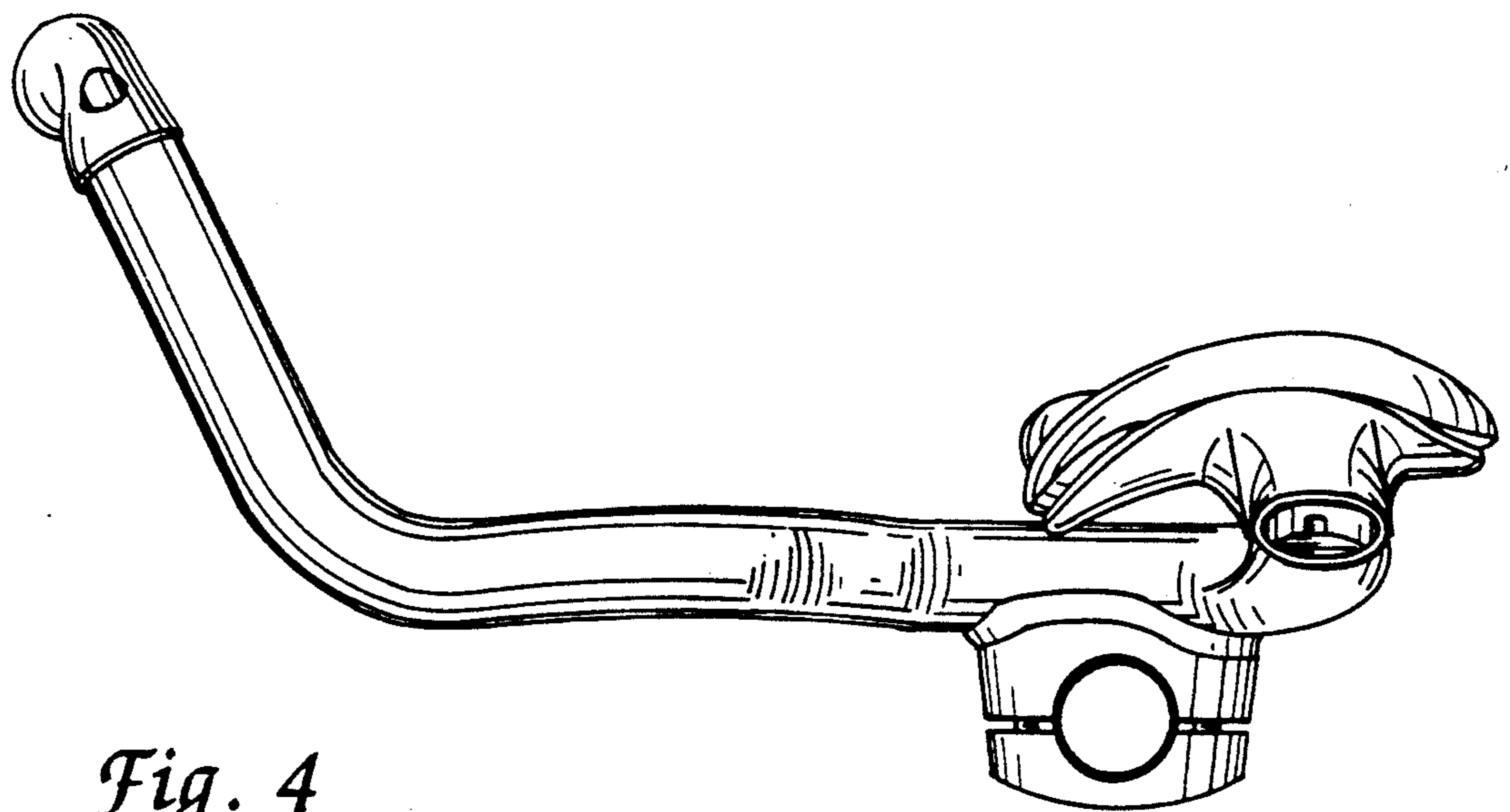
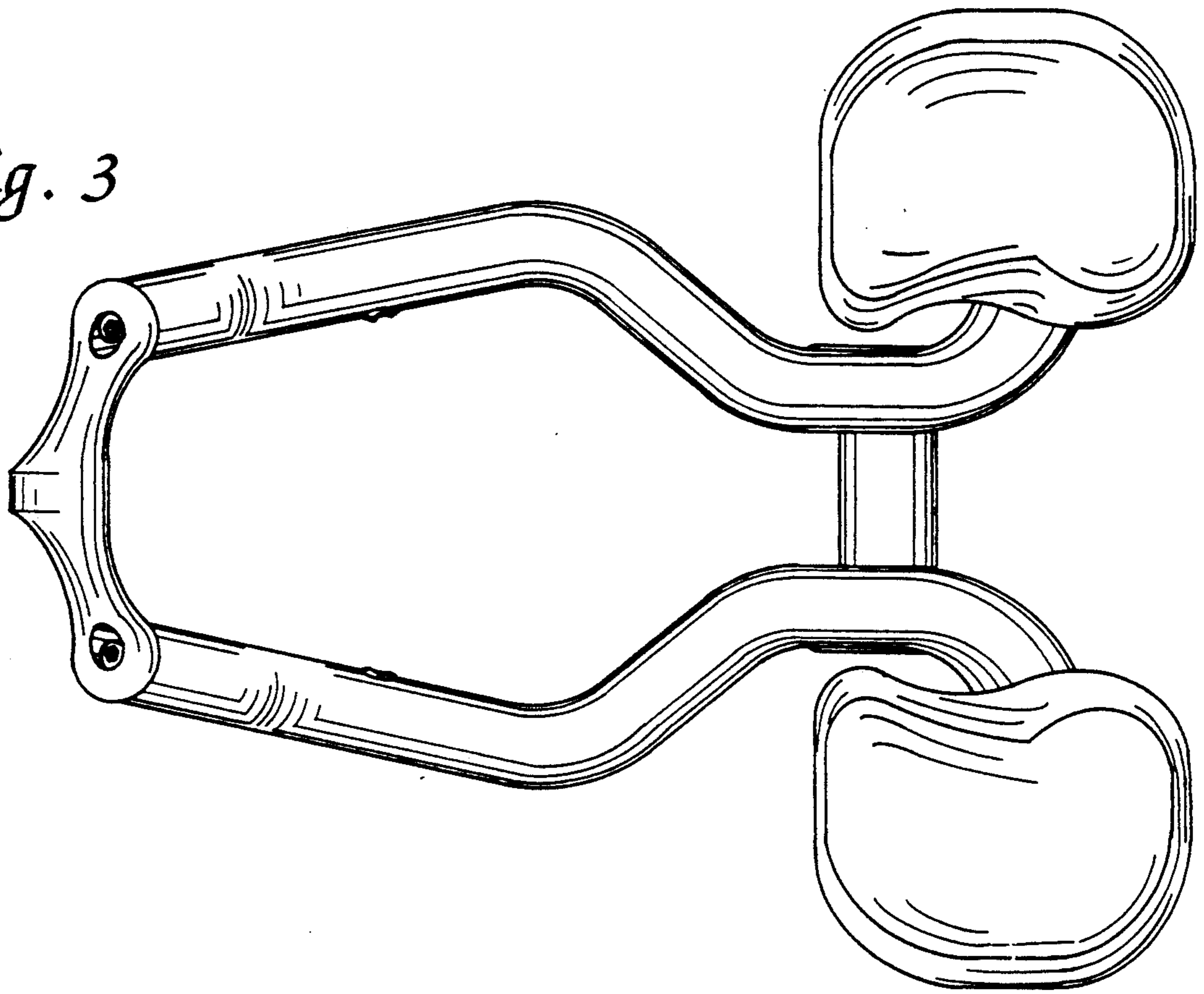

Fig. 4

Fig. 5

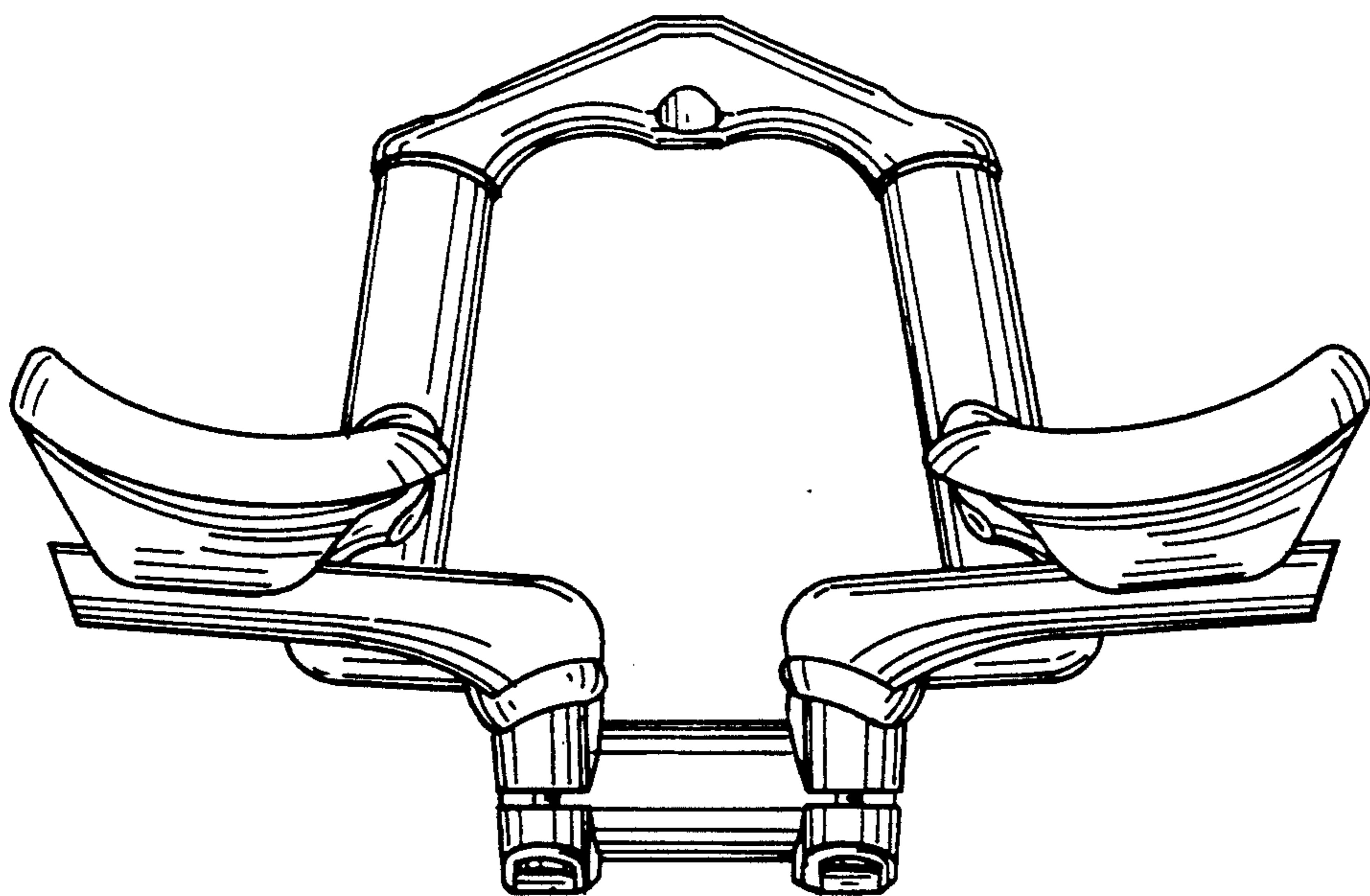
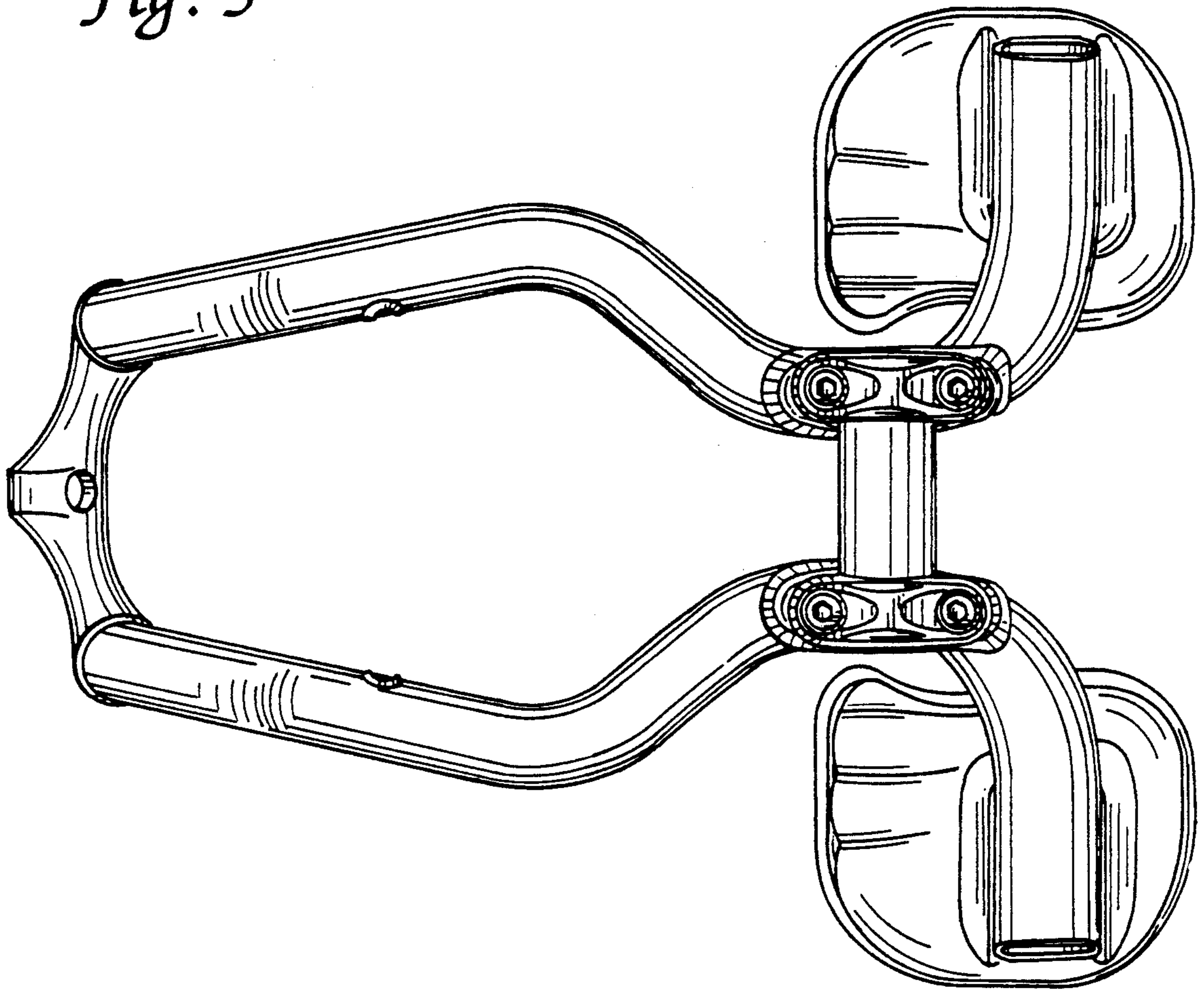

Fig. 6