



US00D334162S

United States Patent [19]

[11] Patent Number: **Des. 334,162**

Cucheran et al.

[45] Date of Patent: **** Mar. 23, 1993**

[54] **VEHICLE LUGGAGE CARRIER**

[75] Inventors: **John S. Cucheran, Lake Orion; Jon D. Sparham, Waterford, both of Mich.**

[73] Assignee: **John A. Bott, Grosse Pointe Farms, Mich.**

[**] Term: **14 Years**

[21] Appl. No.: **687,540**

[22] Filed: **Apr. 19, 1991**

[52] U.S. Cl. **D12/157**

[58] Field of Search **D12/157; 224/309, 316, 224/317, 322-329, 331; 296/37.7**

3,554,416	1/1971	Bott	224/42.1
3,951,320	4/1976	Bott	224/42.10
4,099,658	7/1978	Bott	224/42.1 F
4,133,465	1/1979	Bott	224/42.1
4,146,198	5/1979	Bott	224/32 A
4,156,497	5/1979	Bott	224/326
4,162,755	7/1979	Bott	224/326
4,175,682	11/1979	Bott	224/309
4,182,471	1/1980	Bott	224/326
4,222,508	9/1980	Bott	224/324
4,274,570	6/1981	Bott	224/324
4,295,587	10/1981	Bott	224/321
4,323,182	4/1982	Bott	224/321
4,364,500	12/1982	Bott	224/325
4,431,123	2/1984	Bott	224/321
4,473,178	9/1984	Bott	224/324
4,516,710	5/1985	Bott	224/324
4,684,048	8/1987	Bott	224/326
4,754,905	7/1988	Bott	224/326

[56] **References Cited**
U.S. PATENT DOCUMENTS

D. 204,932	5/1966	Bott	D12/157
D. 212,186	9/1968	Bott	D12/157
D. 215,277	9/1969	Bott	D12/157
D. 215,278	9/1969	Bott	D12/157
D. 217,959	7/1970	Bott	D12/190
D. 222,617	11/1971	Bott	D12/157
D. 250,461	12/1978	Bott	D12/157
D. 250,464	12/1978	Bott	D12/157
D. 264,203	5/1982	Bott	D12/157
D. 282,155	1/1986	Bott	D12/157
D. 283,117	5/1986	Bott	D12/157
D. 300,018	2/1989	Bott	D12/157
D. 306,990	4/1990	Bott	D12/157
D. 314,541	2/1991	Bott	D12/157
D. 314,542	2/1991	Bott	D12/157
D. 320,588	10/1991	Foster et al.	D12/157
3,330,454	7/1967	Bott	224/42.1
3,451,602	6/1969	Bott	224/42.1
3,519,180	7/1970	Bott	224/42.1

Primary Examiner—James M. Gandy
Attorney, Agent, or Firm—Harness, Dickey & Pierce

[57] **CLAIM**

The ornamental design for a vehicle luggage carrier, as shown and described.

DESCRIPTION

FIG. 1 is a perspective view of a vehicle luggage carrier showing our new design, it being understood that the broken lines are for illustrative purposes only and form no part of the claimed design;

FIG. 2 is a side elevational view of the right side thereof;

FIG. 3 is a side elevational view of the left side thereof;

FIG. 4 is a top plan view thereof;

FIG. 5 is a front end elevational view thereof; and,

FIG. 6 is a rear end elevational view thereof.

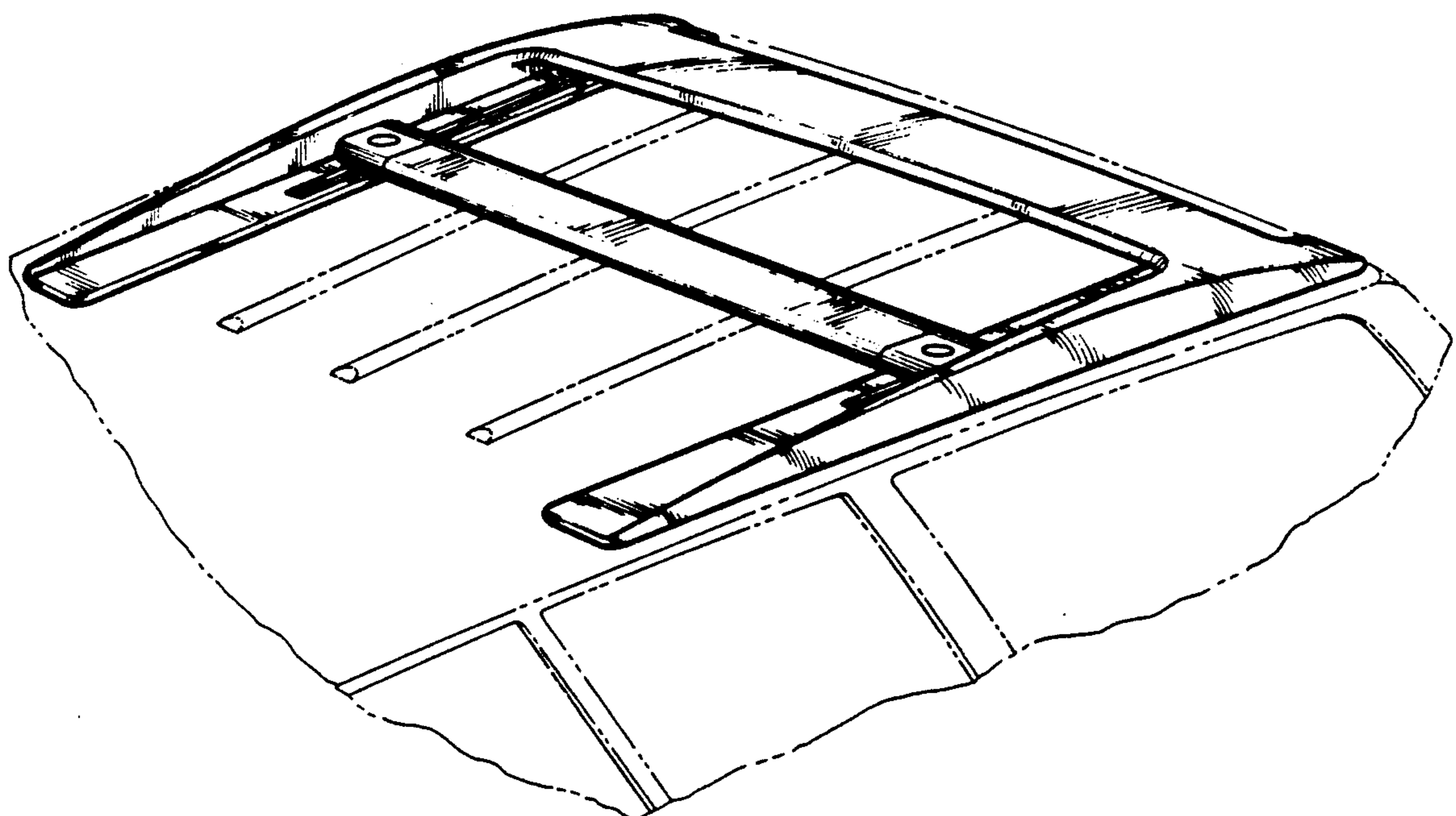

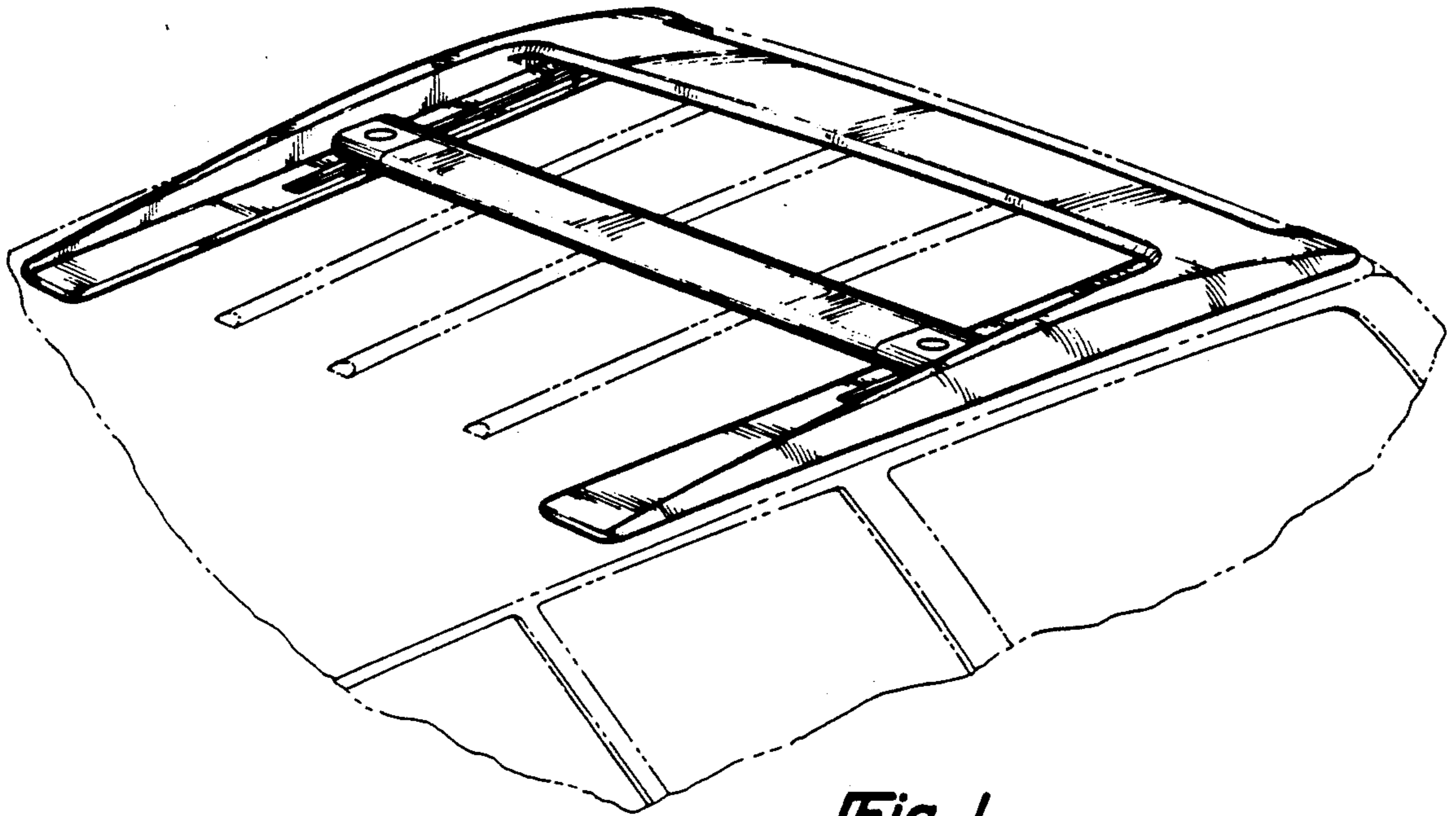

Fig-1



Fig-2



Fig-3

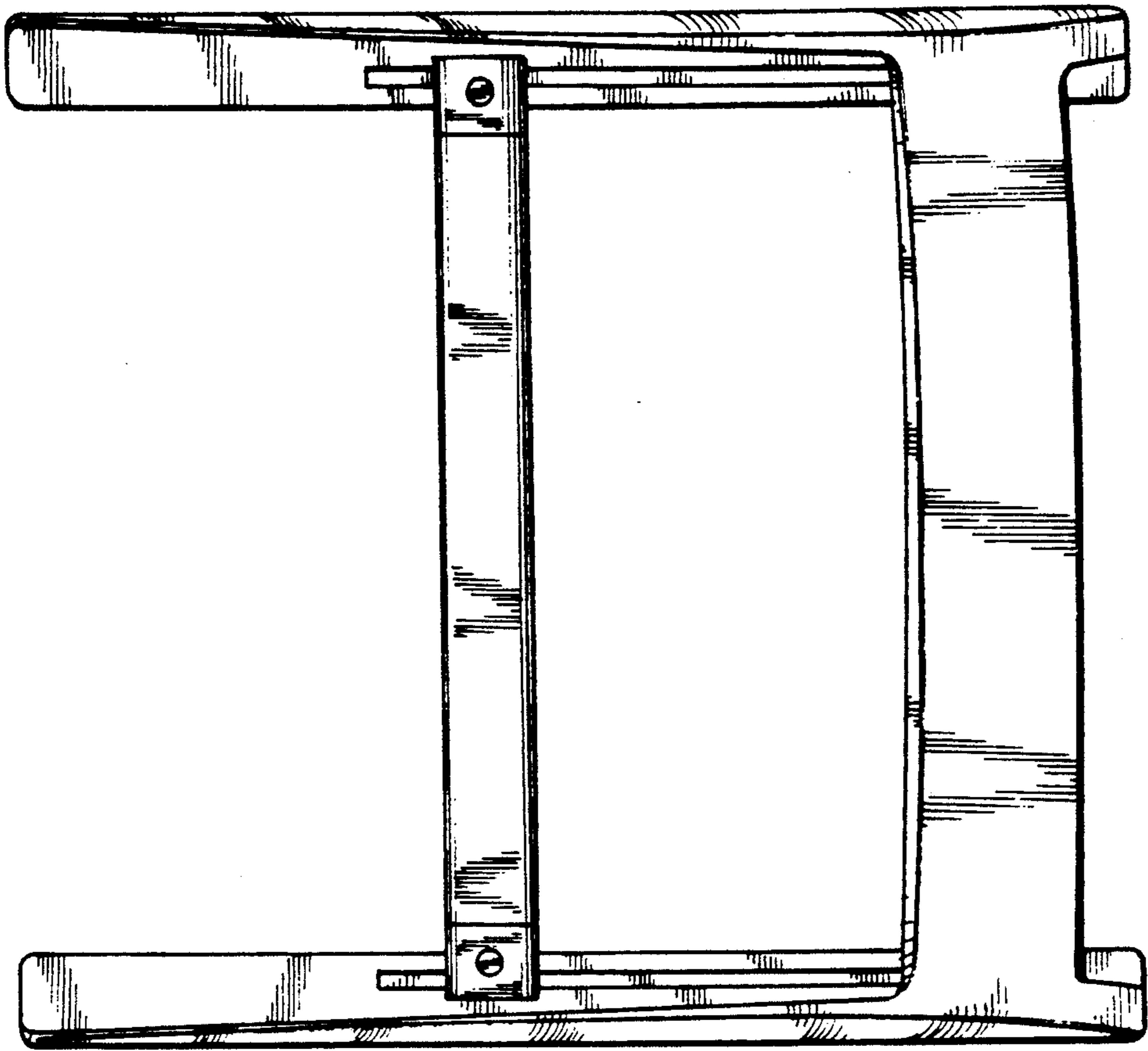

Fig-4

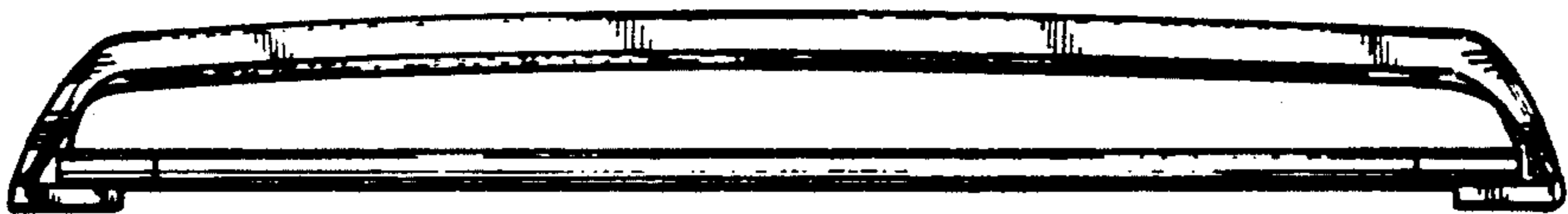

Fig-5

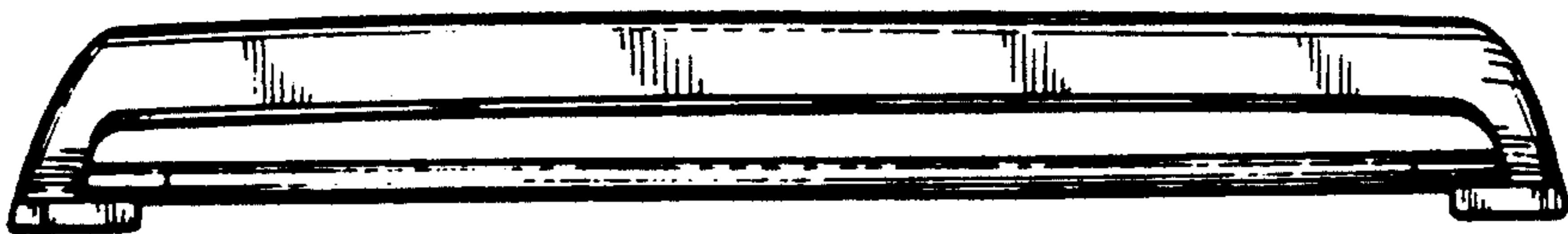

Fig-6