



US00D333999S

United States Patent [19]

[11] Patent Number: **Des. 333,999**

Hatano

[45] Date of Patent: **** Mar. 16, 1993**

[54] CLOCK MOVEMENT

[75] Inventor: **Katsuhiko Hatano, Tokyo, Japan**

[73] Assignee: **Seikosha Co., Ltd., Japan**

[**] Term: **14 Years**

[21] Appl. No.: **539,674**

[22] Filed: **Jun. 18, 1990**

[30] Foreign Application Priority Data

Dec. 20, 1989 [JP] Japan 1-46567

[52] U.S. Cl. **D10/129; D10/128**

[58] Field of Search **D10/1-40, D10/122-132; 368/220, 316, 318, 285, 204, 72, 250, 252**

[56] References Cited

U.S. PATENT DOCUMENTS

D. 311,151 10/1990 Kaneko D10/129

D. 318,024 7/1991 Kaneko D10/129

OTHER PUBLICATIONS

Hong Kong Enterprise—Jun. 1990—p. 118—Clock Mechanism at Center.

*Primary Examiner—Nelson C. Holtje
Attorney, Agent, or Firm—Bruce L. Adams; Van C. Wilks*

[57] CLAIM

The ornamental design for a clock movement, as shown and described.

DESCRIPTION

FIG. 1 is a front elevational view of a clock movement showing my new design;
FIG. 2 is a rear elevational view thereof;
FIG. 3 is a top plan view thereof;
FIG. 4 is a bottom plan view thereof;
FIG. 5 is a left side elevational view thereof;
FIG. 6 is a right side elevational view thereof;
FIG. 7 is a front right elevational view thereof; and,
FIG. 8 is a rear right perspective view thereof.

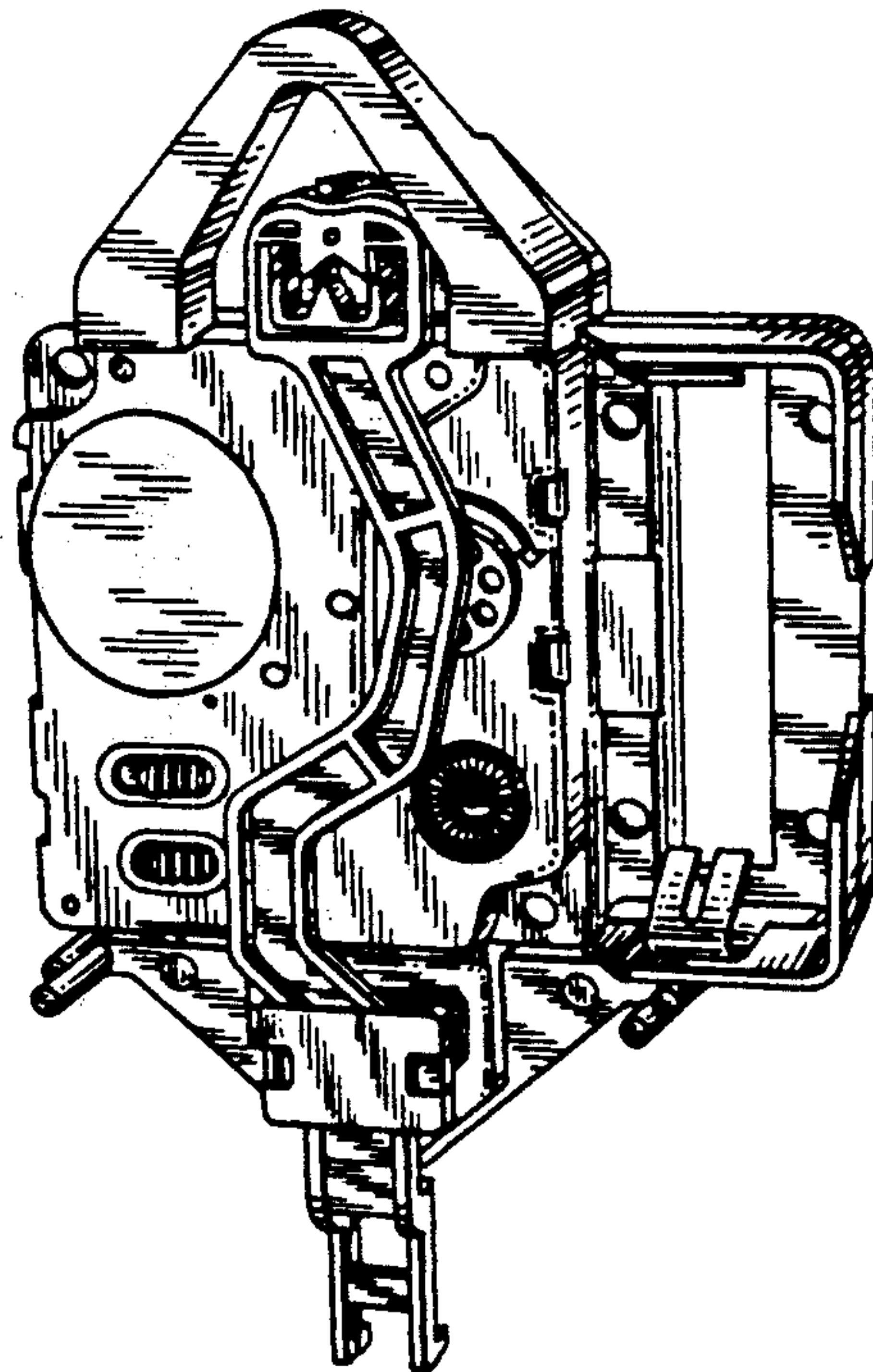

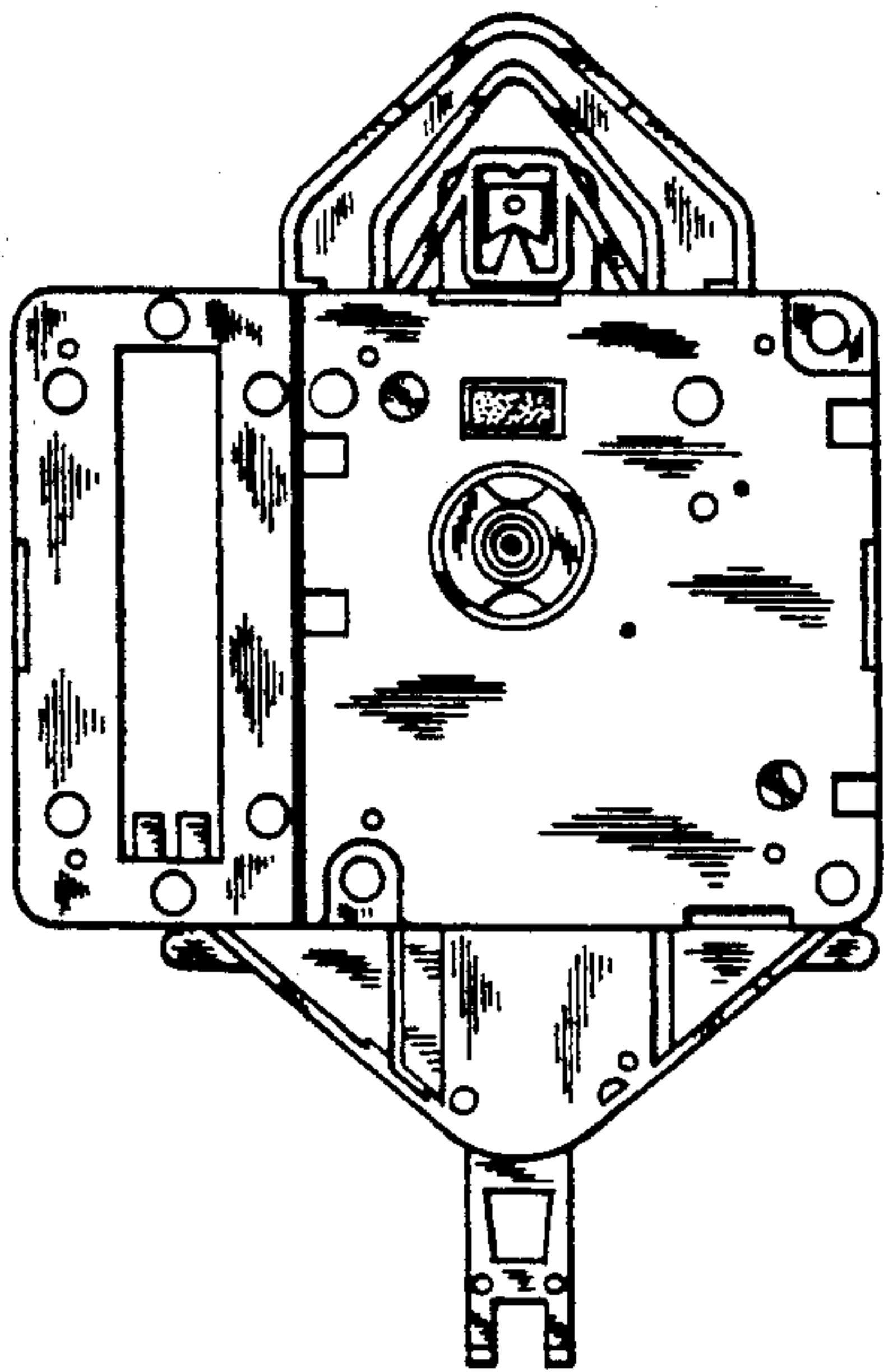

FIG. 1

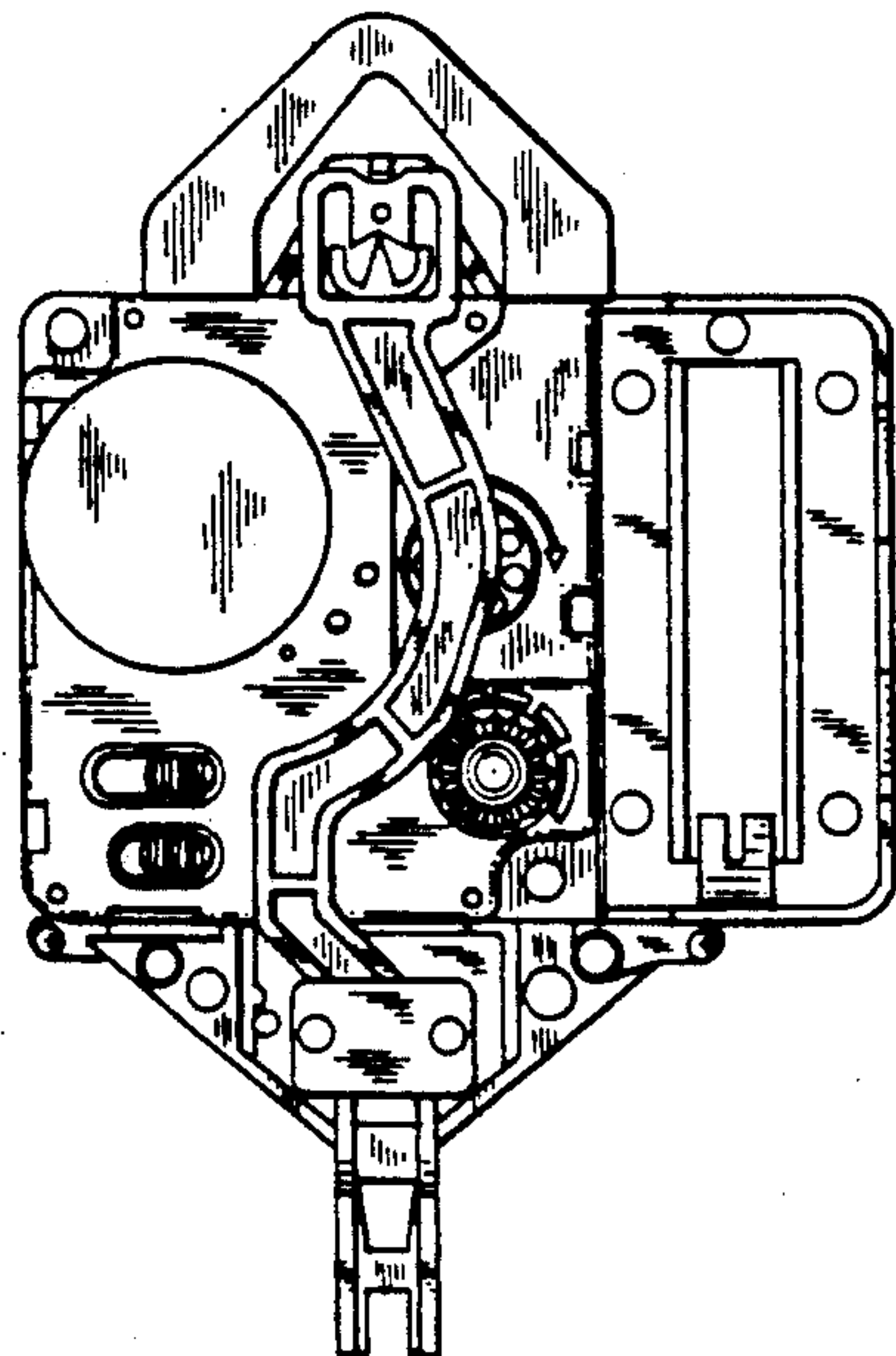

FIG. 2

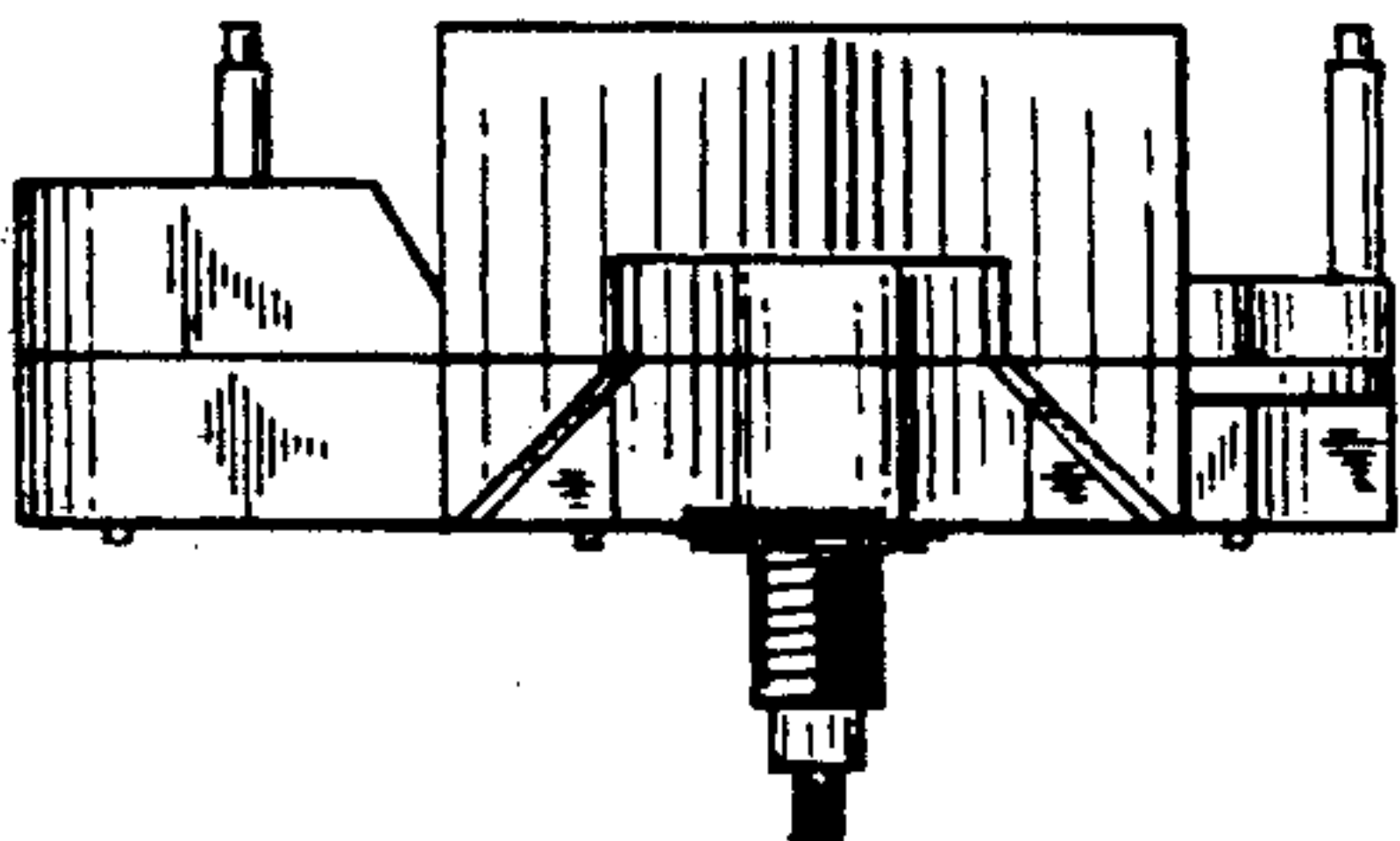

FIG. 3

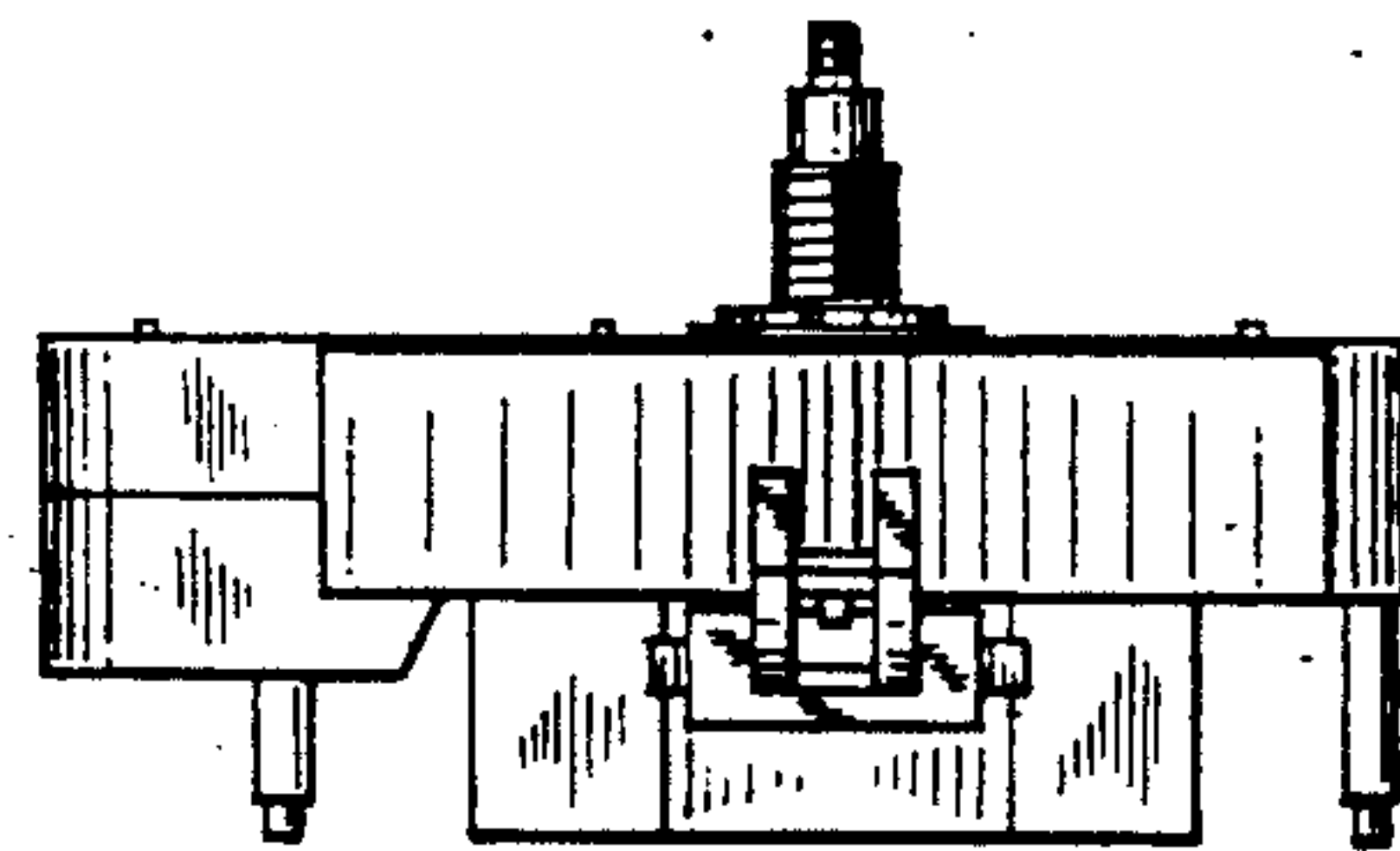

FIG. 4

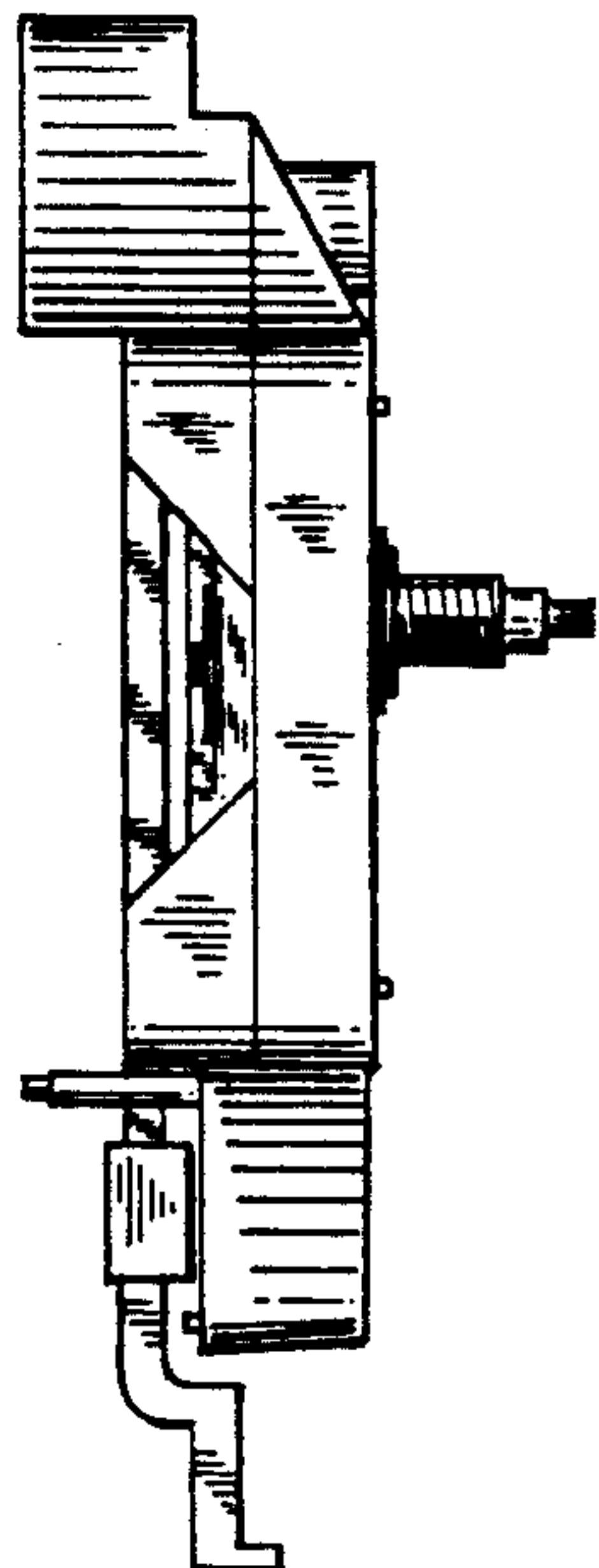

FIG. 5

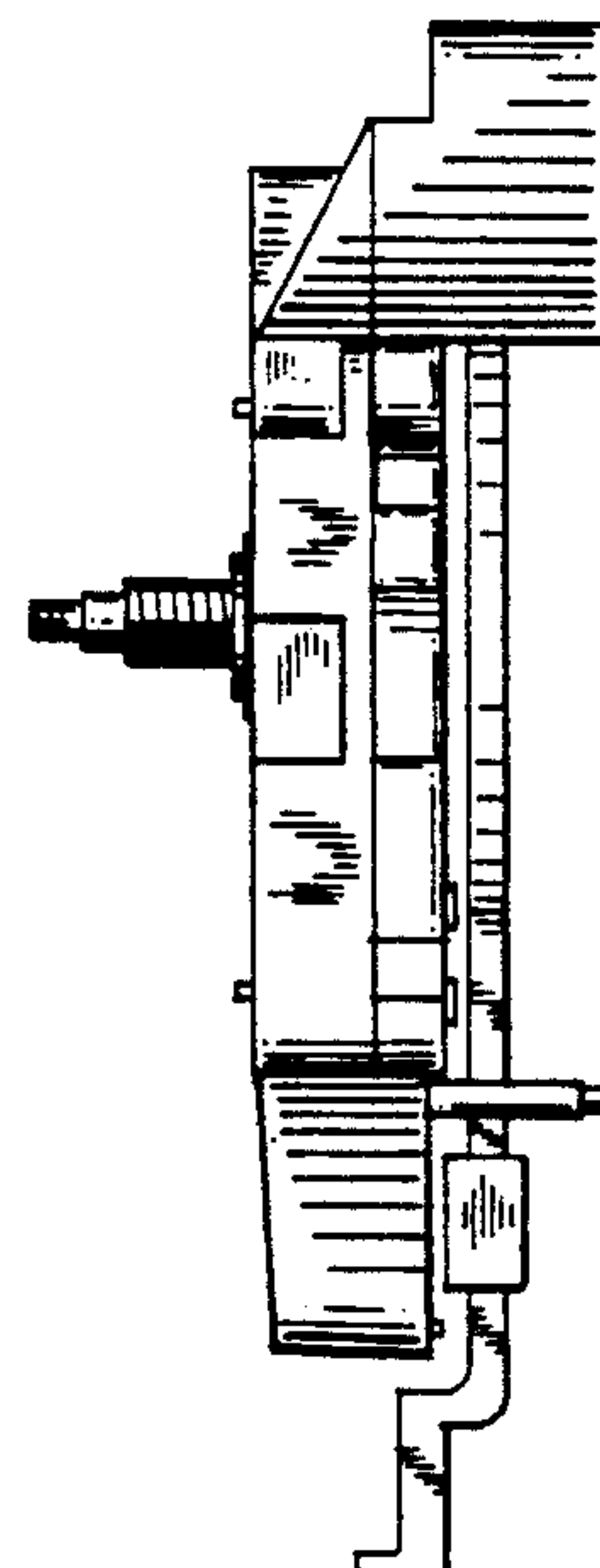

FIG. 6

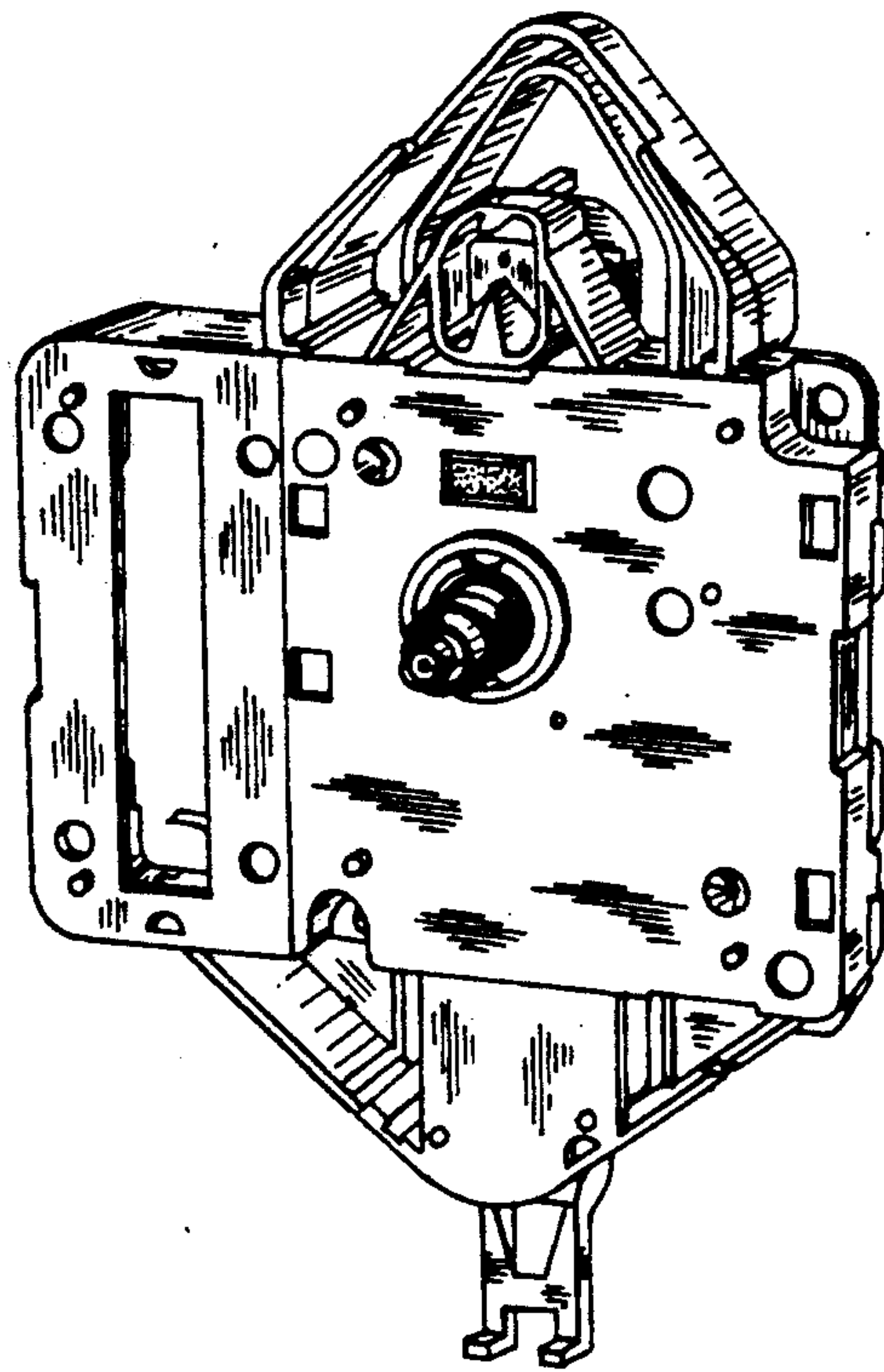

FIG. 7

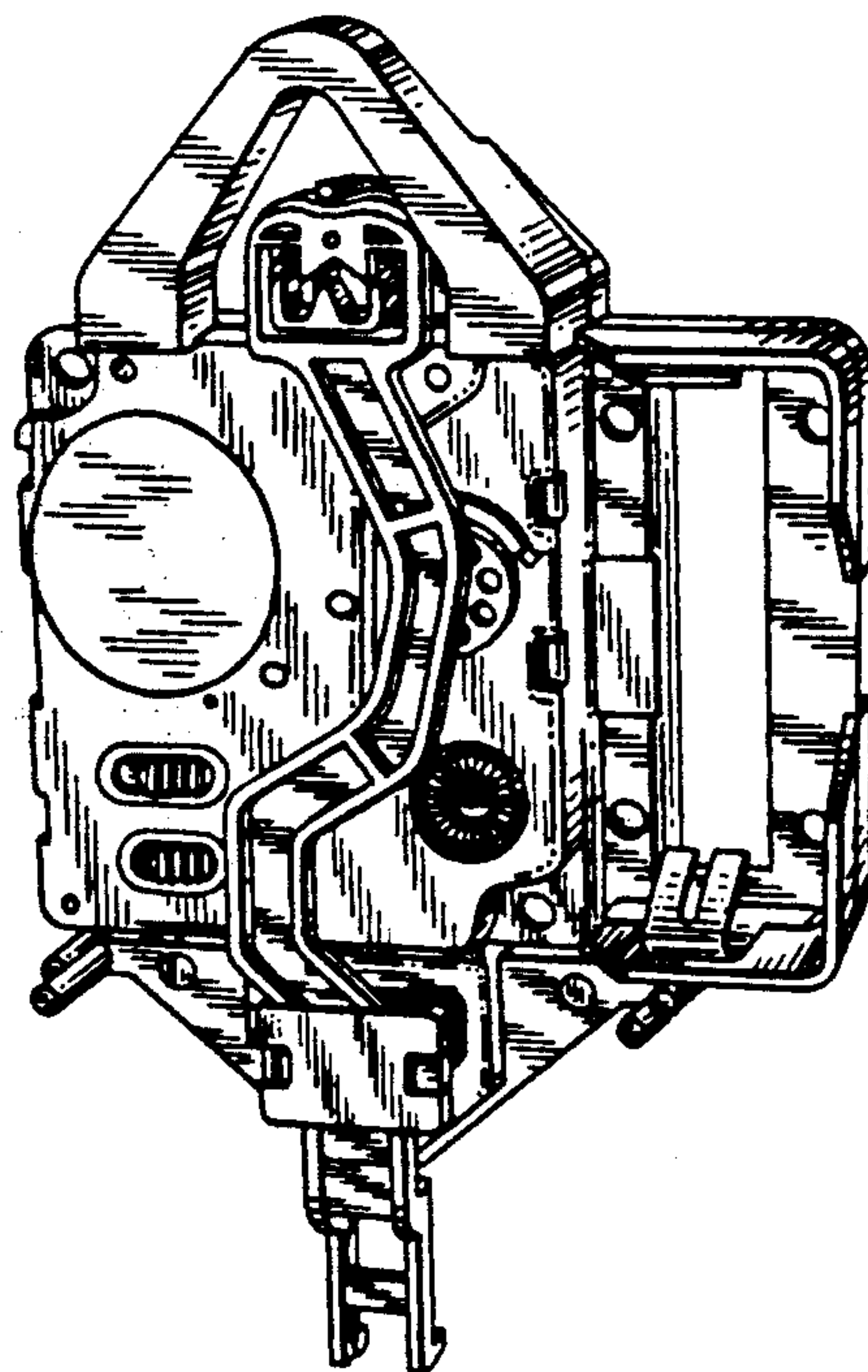

FIG. 8